



IBM System i5, eServer i5, and iSeries System Builder

IBM i5/OS Version 5 Release 4 - January 2006

The authoritative source for current
IBM System i5, eServer i5, and iSeries models

Facts, rules, and placement for the System i5,
eServer i5 and iSeries features

Product numbers, prerequisites, storage
specifications, and software facts

Dick Bresenham
Harold Distler
Glen McClymont
Susan Powers
Gerd Reinhardt
Jerry Watson



Redbooks



International Technical Support Organization

**IBM System i5, eServer i5, and iSeries System Builder
IBM i5/OS Version 5 Release 4 January 2006**

September 2006

Archived

Note: Before using this information and the product it supports, read the information in “Notices” on page ix.

Archived

Thirteenth edition (September 2006)

This edition applies to Version 5 Releases 3 and 4 of IBM i5/OS, Version 5 Releases 1 and 2 of OS/400 (product number 5722-SS1), and Version 4 Releases 1, 2, 3, 4, and 5 (product number 5769-SS1).

This document was created or updated on April 2, 2010.

© Copyright International Business Machines Corporation 1997 - 2006. All rights reserved.

Note to U.S. Government Users Restricted Rights -- Use, duplication or disclosure restricted by GSA ADP Schedule Contract with IBM Corp.

Contents

Notices	ix
Trademarks	x
Preface	xi
Special note	xii
The team that wrote this redbook	xiii
Become a published author	xv
Comments welcome	xv
Chapter 1. IBM System i5, eServer i5 and iSeries upgrades	1
1.1 Upgrades for System i processors	2
1.2 RISC-to-RISC Data Migration	3
Chapter 2. IBM System i5 and eServer i5 models	5
2.1 System i5 Model 520+ overview	7
2.2 eServer i5 Model 520 overview	9
2.3 System i5 Model 550+ and eServer i5 Model 550 overview	12
2.4 System i5 Model 570+ overview	14
2.5 eServer i5 Model 570 overview	16
2.6 System i5 and eServer i5 Model 595 overview	19
2.7 Notes for System i5 and eServer i5 Models 520, 550, 570, and 595	21
2.8 9405 and 9406 Models 520+ and 520 system unit schematics	27
2.8.1 Model 520+ top view	27
2.8.2 Model 520+ front view	28
2.8.3 Model 520+ back view	28
2.8.4 Model 520 top view	29
2.8.5 Model 520 front view	29
2.8.6 Model 520 back view	30
2.9 9406 Models 550+ and 550 system unit schematics	30
2.9.1 Models 550+ and 550 top view	30
2.9.2 Models 550+ and 550 front view	31
2.9.3 Models 550+ and 550 back view	32
2.9.4 Models 550+ and 550 memory layout	32
2.10 9406 Models 570+ and 570 system unit schematics	33
2.10.1 Model 570+ top view	33
2.10.2 Models 570+ and 570 front view	34
2.10.3 Models 570+ and 570 back view	35
2.10.4 Model 570 top view	36
2.10.5 Model 570 front view	37
2.10.6 Models 570+ and 570 memory layout	37
2.11 9406 Model 595 system unit schematics	38
2.11.1 Model 595 front view	38
2.11.2 Model 595 back view	39
2.11.3 Models 595+ and 595 memory layout	40
2.12 System i5 Model 520+ and eServer 520 processors	41
2.13 IBM System i5 and eServer i5 Model 550 processors	46
2.14 IBM System i5 and eServer i5 Model 570 processors	48
2.15 IBM System i5 and eServer Model 595 processors	54
2.16 IBM System i5 and eServer i5 features	58

2.17 Supported upgrades for System i5 and eServer i5 models	58
Chapter 3. iSeries 800, 810, 825, 870, and 890 models	59
3.1 iSeries Model 800 overview	60
3.2 iSeries Model 810 overview	61
3.3 iSeries Model 825 overview	63
3.4 iSeries Model 870 overview	65
3.5 iSeries Model 890 overview	66
3.6 Notes for iSeries Models 800, 810, 825, 870, and 890 overview	68
3.7 9406 Model 800 system unit schematic	73
3.8 9406 Model 810 system unit schematic	74
3.9 iSeries Models 800 and 810 #7116 System Unit Expansion schematic	75
3.10 9406 Model 825 system unit schematic	76
3.11 9406 Model 870 system unit schematic	78
3.11.1 Model 870 MCM and HSL relationship	80
3.12 9406 Model 890 system unit schematic	81
3.12.1 Model 890 MCM and HSL relationship	83
3.13 iSeries Models 870 and 890 #9094 Base PCI I/O Enclosure schematic	85
3.13.1 #9094 PCI Card Enclosure schematic	86
3.14 iSeries Models 870 and 890 #8094 Optional 1.8 m I/O Rack schematic	87
3.15 iSeries Model 800 processors	88
3.16 iSeries Model 810 processors	89
3.17 iSeries Model 825 processors	91
3.18 iSeries Model 870 processors	92
3.19 iSeries Model 890 processors	93
3.20 iSeries Models 800, 810, 825, 870, and 890 features	95
3.21 Supported upgrades for Models 800, 810, 825, 870, and 890	95
Chapter 4. IBM System i5, eServer i5, and iSeries features and placement	97
4.1 PCI card placement for IBM System i5, eServer i5 and iSeries servers	98
4.2 Power and packaging	98
4.3 i5/OS partitions on eServer p5 servers	156
4.4 Models 825, 870, and 890 Capacity on Demand	156
4.5 Main storage	159
4.6 PCI IOP controllers	173
4.6.1 IOP-less IOAs and placement	185
4.7 Workstation controllers and console features	190
4.8 LAN and WAN adapters	192
4.9 Disk units	216
4.10 Internal tape units and CD-ROM	221
4.11 Magnetic media controllers	228
Chapter 5. Customer Install Features	247
5.1 IBM System i5 and eServer Models 520, 550, 570, 595 system unit and tower supported features	248
5.2 IBM eServer iSeries Models 800, 810, 825, 870, #2497/#2498 890 system unit and tower supported features	264
Chapter 6. System i5, eServer i5 and iSeries towers schematics	275
6.1 System i towers, racks, and expansion unit schematics	277
6.1.1 #5074 PCI Expansion Tower	277
6.1.2 #5075 PCI Expansion Tower	278
6.1.3 #5078/#0578 PCI Expansion Unit	279
6.1.4 #5079 1.8 m I/O Tower	279

6.1.5 #5088/#0588 PCI-X Expansion Unit	281
6.1.6 #5094 PCI Expansion Tower	282
6.1.7 #5095/#0595 PCI-X Expansion Tower	283
6.1.8 #5294 PCI-X Expansion Tower	284
6.1.9 #5790 PCI Expansion Drawer	285
6.1.10 #8093 Optional Base 1.8 m I/O Rack	285
6.1.11 #8094 Optional 1.8 m I/O Rack	287
6.1.12 #9094 Base PCI I/O Enclosure	288
6.1.13 #9094 PCI Card Enclosure	289
6.2 Required EIA units	289
Chapter 7. Storage and media for IBM System i5, eServer i5, and iSeries models	291
7.1 External tape for System i5, eServer i5, and iSeries systems	292
7.1.1 Alternate IPL or alternate installation device	293
7.2 SAN components for IBM System i5, eServer i5 and iSeries systems	293
7.3 QIC tape specifications and compatibility for IBM System i5, eServer i5, and iSeries systems	294
7.4 VXA and LTO tape specifications and compatibility for IBM System i5, eServer i5, and iSeries systems	295
7.5 External SCSI, Fibre Channel tape, and optical cable part numbers for IBM System i5, eServer i5, and iSeries systems	296
7.6 Device cabling rules for #5702, #5705, #5712, #5715, #2718, and #2768 PCI Magnetic Media Controller	300
Chapter 8. Customer Card Identification Numbers cross reference	303
Chapter 9. Feature code cross reference	323
Chapter 10. Software for the System i5, eServer i5, and iSeries models	341
10.1 Minimum i5/OS and OS/400 software level requirements for System i5, eServer i5, and iSeries hardware	342
10.2 i5/OS and OS/400 general availability and support	345
10.3 i5/OS and OS/400 upgrade paths	345
10.4 Current-release to previous-release support for i5/OS and OS/400	346
10.5 Software ordering terminology	346
10.6 i5/OS V5R4 software	346
10.7 i5/OS V5R3 software	351
10.8 OS/400 V5R2 software	356
10.9 OS/400 V5R1 software	362
10.10 Notes for Version 5 software tables	366
10.11 i5/OS and OS/400 software pricing groups	369
10.11.1 i5/OS and OS/400 Version 5 software groups	369
10.11.2 OS/400 Version 4 software groups	372
10.12 Release-to-release software product mapping	374
Chapter 11. HSL, SPCN, line cord, and communication cables for IBM System i5, eServer i5, and iSeries systems	377
11.1 HSL cables	378
11.1.1 HSL cable feature descriptions	380
11.2 SPCN (power) cables	382
11.3 Dual line cords	383
11.4 Communication cables	385
Chapter 12. Summary of AS/400 CISC models	389

12.1 AS/400 Model P02, P03, and 10S capacities	390
12.1.1 Model P02 capacities	390
12.1.2 Model P03 and 10S capacities	390
12.2 AS/400 Model Y10, 236, and 436 capacities	391
12.2.1 Model Y10 capacities	391
12.2.2 Model 236 and 436 capacities	391
12.2.3 Model 436 package capacities	393
12.3 AS/400 Model C, D, E, and F capacities	394
12.3.1 Model C and D capacities	394
12.3.2 Model E and F capacities	395
12.4 AS/400 Model 200, 20S, 1xx, and 3xS capacities	396
12.4.1 Model 1xx, 20S, and 3xS capacities	396
12.4.2 Model 200 capacities	397
12.4.3 Model 20S package capacities	397
12.5 AS/400 Model B, C, D, E, and F capacities	398
12.5.1 Model B and C capacities	398
12.5.2 Model D and E capacities	399
12.5.3 Model F capacities	399
12.6 AS/400 Model B, D, E, F, and 3xx capacities	400
12.6.1 Model B capacities	400
12.6.2 Model D capacities	401
12.6.3 Model E capacities	402
12.6.4 Model F capacities	403
12.6.5 Model 300, 310, and 320 capacities	404
12.7 Notes for all CISC system summary tables	405
Chapter 13. Summary of AS/400e RISC models	407
13.1 AS/400e Model S10, S20, S30, and S40 capacities	409
13.1.1 Model S10 capacities	409
13.1.2 Model S20 capacities	410
13.1.3 Model S30 capacities	411
13.1.4 Model S40 capacities	412
13.2 AS/400e Model 150 capacities	413
13.3 AS/400e Model 4HS, 4HE, 4HG, 4HL, 42E, 42G, and 42L packages and Model 4SS, 4SE, 4SG, 4TG, 4SL, 4TL, 40E, 41E, 40G, 41G, 40L, 41L, 400, and 40S capacities	415
13.3.1 Model 4HS, 4HE, 4HG, and 4HL package capacities	415
13.3.2 Model 42E, 42G, and 42L package capacities	415
13.3.3 Model 4SS, 4SE, 4SG, 4TG, 4SL, and 4TL capacities	416
13.3.4 Model 40E, 41E, 40G, 41G, 40L, and 41L capacities	416
13.3.5 Model 400 capacities	417
13.3.6 Model 40S capacities	418
13.4 AS/400e Model 50S, 53S, 500, 510, and 530 capacities	419
13.4.1 Model 50S, and 53S capacities	419
13.4.2 Model 500, 510, and 530 capacities	420
13.5 AS/400e Model 600, 620, 640, and 650 capacities	421
13.5.1 Model 600 capacities	421
13.5.2 Model 620 capacities	422
13.5.3 Model 640 and 650 capacities	423
13.6 Notes for all RISC system summary tables	424
Related publications	425
IBM Redbooks	425
Other publications	426

Online resources	426
How to get IBM Redbooks	427
Help from IBM	427

Archived

Archived

Notices

This information was developed for products and services offered in the U.S.A.

IBM may not offer the products, services, or features discussed in this document in other countries. Consult your local IBM representative for information on the products and services currently available in your area. Any reference to an IBM product, program, or service is not intended to state or imply that only that IBM product, program, or service may be used. Any functionally equivalent product, program, or service that does not infringe any IBM intellectual property right may be used instead. However, it is the user's responsibility to evaluate and verify the operation of any non-IBM product, program, or service.

IBM may have patents or pending patent applications covering subject matter described in this document. The furnishing of this document does not give you any license to these patents. You can send license inquiries, in writing, to:

IBM Director of Licensing, IBM Corporation, North Castle Drive, Armonk, NY 10504-1785 U.S.A.

The following paragraph does not apply to the United Kingdom or any other country where such provisions are inconsistent with local law: INTERNATIONAL BUSINESS MACHINES CORPORATION PROVIDES THIS PUBLICATION "AS IS" WITHOUT WARRANTY OF ANY KIND, EITHER EXPRESS OR IMPLIED, INCLUDING, BUT NOT LIMITED TO, THE IMPLIED WARRANTIES OF NON-INFRINGEMENT, MERCHANTABILITY OR FITNESS FOR A PARTICULAR PURPOSE. Some states do not allow disclaimer of express or implied warranties in certain transactions, therefore, this statement may not apply to you.

This information could include technical inaccuracies or typographical errors. Changes are periodically made to the information herein; these changes will be incorporated in new editions of the publication. IBM may make improvements and/or changes in the product(s) and/or the program(s) described in this publication at any time without notice.

Any references in this information to non-IBM Web sites are provided for convenience only and do not in any manner serve as an endorsement of those Web sites. The materials at those Web sites are not part of the materials for this IBM product and use of those Web sites is at your own risk.

IBM may use or distribute any of the information you supply in any way it believes appropriate without incurring any obligation to you.

Information concerning non-IBM products was obtained from the suppliers of those products, their published announcements or other publicly available sources. IBM has not tested those products and cannot confirm the accuracy of performance, compatibility or any other claims related to non-IBM products. Questions on the capabilities of non-IBM products should be addressed to the suppliers of those products.

This information contains examples of data and reports used in daily business operations. To illustrate them as completely as possible, the examples include the names of individuals, companies, brands, and products. All of these names are fictitious and any similarity to the names and addresses used by an actual business enterprise is entirely coincidental.

COPYRIGHT LICENSE:

This information contains sample application programs in source language, which illustrate programming techniques on various operating platforms. You may copy, modify, and distribute these sample programs in any form without payment to IBM, for the purposes of developing, using, marketing or distributing application programs conforming to the application programming interface for the operating platform for which the sample programs are written. These examples have not been thoroughly tested under all conditions. IBM, therefore, cannot guarantee or imply reliability, serviceability, or function of these programs.

Trademarks

The following terms are trademarks of the International Business Machines Corporation in the United States, other countries, or both:

Advanced Function Printing™
AFP™
AIX 5L™
AIX®
AS/400e™
AS/400®
CICS®
DataPropagator™
Domino®
DB2 OLAP Server™
DB2 Universal Database™
DB2®
DS6000™
DS8000™
Electronic Service Agent™
Enterprise Storage Server®
ESCON®

eServer™
iSeries™
i5/OS®
Infoprint®
Intelligent Miner™
IBM®
IBMLink™
Lotus Enterprise Integrator®
Lotus®
Magstar®
MQSeries®
Netfinity®
NetView®
Operating System/400®
OS/400®
Passport Advantage®
Print Services Facility™

POWER™
POWER4™
POWER5™
POWER5+™
QuickPlace®
QMF™
Redbooks™
Redbooks (logo) ™
System i™
System i5™
System/36™
System/38™
Tivoli®
TotalStorage®
WebSphere®
xSeries®
1350™

The following terms are trademarks of other companies:

IPX, Java, Ultra, and all Java-based trademarks are trademarks of Sun Microsystems, Inc. in the United States, other countries, or both.

Windows NT, Windows Server, Windows, and the Windows logo are trademarks of Microsoft Corporation in the United States, other countries, or both.

Intel, Pentium, Intel logo, Intel Inside logo, and Intel Centrino logo are trademarks or registered trademarks of Intel Corporation or its subsidiaries in the United States, other countries, or both.

Linux is a trademark of Linus Torvalds in the United States, other countries, or both.

Other company, product, or service names may be trademarks or service marks of others.

Preface

Welcome to the thirteenth worldwide-distributed finished edition of the *IBM System i5, eServer i5, and iSeries System Builder*, SG24-2155. This IBM® Redbook offers you a comprehensive guide to the System i™ processor hardware and feature components marketed by IBM representatives since the introduction of the AS/400e™ servers in 1996. This -12 edition covers the newest members of the IBM System i product line, the POWER5+™ Models 520, 550, 570, the 1.9 GHz Model 595, as well as the POWER5™ Models 520, 550, 570, and 595. Information on the IBM eServer™ iSeries™ Models 800, 810, 825, 870, and Model 890 is also presented.

Note: System i is a term that describes the combination of IBM System i5™, eServer i5, eServer iSeries, and AS/400e product lines. IBM System i5 is the follow-on product line to the eServer i5 and iSeries systems.

To help distinguish the different models and technology in this IBM Redbook, the System i5 name is used to specifically reference the 1.9 GHz Models 520, 550, and 595, and the 2.2 GHz Model 570 announced on 31 January 2006. These processors are also known as the the POWER5+ Models 520, 550, 570, and the #8966 Model 595. The eServer i5 name is used to reference the 520, 550, 570, and 595 POWER5 models announced in 2005 and 2004.

This IBM Redbook has been updated to describe the prerequisites and placement rules for features and devices supported by these processors, as well as the latest release of the operating system, IBM i5/OS® Version 5 Release 4, and associated program products.

In the interest of maintaining the size of the *System Builder*, information on earlier models of the iSeries and AS/400e product line was extracted into a separate Redpaper, after the October 2005 edition was produced as *IBM eServer i5, iSeries, and AS/400e System Builder IBM i5/OS Version 5 Release 3 - October 2005*, SG24-2155-11. For details on the iSeries Models 250, 270, 820, 830, 840, SB2 and SB3, as well as the AS/400e Models 170, 720, 730, and 740, with corresponding feature and software information (through OS/400 V5R2), refer to *IBM eServer iSeries and AS/400e System Builder: IBM OS/400 Version 4 Release 3 - Version 5 Release 2*, REDP-0542.

The System Builder is written for an IBM audience of System Specialists, Marketing Representatives, Business Partners, and clients. Use this IBM Redbook when planning, ordering, and installing new systems, and when performing model upgrades or installing additional features, and as a technical reference for detailed System i information and configuration rules. Refer to the companion guide *IBM System i5 Handbook*, SG24-7486, for the current marketing view of the System i product line. Refer to *IBM eServer iSeries Migration: A Guide to Upgrades and Migrations to POWER Technology*, SG24-7200, for migration considerations to these systems.

The flexibility of configuration offered on today's systems can add an increased requirement to understand the detailed configuration rules. Plan for the placement of I/O processors (IOPs) and I/O adapters (IOAs) to affect a more efficient use of card slots, which can then result in a lower cost of implementation. For placement rules and restrictions beyond what is described in this IBM Redbook, see *PCI and PCI-X Placement Rules for IBM System i5, eServer i5, and iSeries servers with i5/OS V5R4 and V5R3*, REDP-4011. See Table 4-2 on page 186 for a list of IOAs that do not require an IOP.

For workload and performance information about servers, disk components, communications features, and more, refer to *iSeries Performance Capabilities Reference*, SC41-0607.

This IBM Redbook serves as an extensive guide for configuration and installation support. It is an authoritative source. Use online systems (including the IBM marketing configurator, announcement letters, and online sales manuals) to verify client orders. Consult your IBM marketing and service representatives to help implement the best solution for your business.

We continually receive feedback and suggestions for improvement on the contents and layout of this IBM Redbook and do our best to accommodate them. If you have further suggestions or comments regarding the content, layout, and usefulness of this book, we welcome your input. We intend to do whatever is necessary to continue to improve this publication so that it remains as useful as possible for those who need it most.

Note: This is the thirteenth edition of the *IBM System i5, eServer i5, and iSeries System Builder*, SG24-2155. The book title includes the January 2006 date to reflect the latest System i5 announcements represented in this book.

Special note

This IBM Redbook is organized into chapters on IBM System i5 and eServer i5 processors, iSeries processors, and features, and towers common to these IBM System i models. The chapters on processors include summary charts that show the capacity of each model, system diagrams, and descriptions of the processor features.

Feature descriptions and rules for the IBM System i5, eServer i5 and iSeries processors are in a chapter common to the supporting models. This feature chapter, that is Chapter 4, is divided into these categories: power and packaging, capacity on demand, main storage, Peripheral Component Interconnect (PCI) input/output processor (IOP) controllers, workstation controllers and console features, local area network (LAN) and wide area network (WAN) adapters, disk units, internal tape and CD-ROM units, and magnetic media controllers. Features are listed in numerical sequence within each category.

External storage components (storage devices and QIC formats), CCIN and feature tables, cables, and software information is organized in stand-alone chapters. They serve to complement the hardware content described in the mainstay of this IBM Redbook.

Every chargeable feature is included in this book. Since nonchargeable features might need to be ordered, some of these features are also listed in this document. Note that the items listed in this book might not be announced in all countries (regions).

Note: The models represented in this book are each supported by i5/OS Version 5 Release 4.

For CISC and RISC models, only summary tables are in this document. For readers who still require CISC information, refer to *AS/400 CISC System Builder*, REDP-0042. For readers who still require RISC information, refer to *IBM eServer AS/400e RISC System Builder Version 3 Release 6 - Version 5 Release 2*, REDP-0342.

For iSeries models earlier than the 800, 810, 825, 870, and 890 models, refer to *IBM eServer iSeries and AS/400e System Builder: IBM OS/400 Version 4 Release 3 - Version 5 Release 2*, REDP-0542.

To order a copy or copies of this IBM Redbook, as well as the other publications referenced in this IBM Redbook, see “Related publications” on page 425.

The team that wrote this redbook

This redbook was produced by a team of specialists from around the world working at the International Technical Support Organization (ITSO), Rochester Center. It is a result of close cooperation of the ITSO with IBM Rochester engineering and development teams. ITSO residents and partners dedicated their skills and time, serving on ITSO residencies with continual support from around the world throughout 2006.

Dick Bresenham is a Senior iSeries Techline Specialist on the Western Area team in Dallas, Texas, providing iSeries pre-sales technical marketing support. Prior to joining IBM Techline, he was a System/36™, System/38™, and AS/400/iSeries Systems Engineer. He joined IBM as a Process Engineer in Austin, Texas, and has 21 years of service with IBM.

Harold Distler is an iSeries Product Specialist involved with pre-sales and post-sales support for iSeries hardware, operating system, and software for Sirius Computing Solutions. He is also familiar with other platforms and networking. His 25-year career in the computing industry includes 17 years with IBM. He was an IBM Customer Engineer for office products, unit record, System/32, System/34, System/36, and System/38 systems. He also provided Level 2 support for PC hardware and AIX®. He was involved in RT/PC development before he moved into the field as an Open Systems System Engineer.

Glen McClymont is a Senior AS/400® Techline Specialist with IBM in Canada. Since 1988, he has worked with the iSeries server in customer hardware support, software support, and most recently in pre-sales marketing support. Glen has 30 years with IBM. He is an alumni resident for the ITSO from previous Handbook and Builder residencies, providing expertise between updates.

Susan Powers is a Consulting I/T Specialist at the ITSO, Rochester Center. Prior to joining the ITSO in 1997, she was an AS/400 Technical Advocate in the IBM Support Center with a variety of communications, performance, and work management assignments. Her IBM career began as a Program Support Representative and Systems Engineer in Des Moines, Iowa. She holds a degree in Mathematics, with an emphasis in Education, from St. Mary's College of Notre Dame. She is the Project Manager for the iSeries Handbook and System Builder suite of IBM Redbooks™.

Gerd Reinhardt is a Hardware Support Center Specialist for i5, iSeries, and AS/400 midrange systems in IBM Germany. He has a certificate in electronics and holds an advanced technical college certificate. He received a diploma in Business Administration from the academy of Bad Harzburg. He joined the Regional Front End Team in Germany in 1997 providing support to customers located in Austria, Germany and Switzerland, specializing in hardware technical support and problem determination. In April 2004 he joined the EMEA Virtual Front End Team providing Level 2 Support for clients located throughout Europe.

Jerry Watson, an iSeries Systems Specialist, has been with IBM United Kingdom for 21 years. His participation in the production of this redbook started with the V4R1 edition in 1997. He initially worked as an AS/400 Systems Engineer with customers in the London area, before moving to iSeries Techline Europe providing presales Technical support for clients in the UK, South Africa, and Nordic countries.

Thanks to the following developers and engineers who assisted in answering questions, providing input, and validating output:

- ▶ For input on iSeries processors and features:
Gerald Allen
Denis Nizinski
Jeff Trachy
Dave Wells, team leader
- ▶ For input on iSeries I/O configuration and placement rules:
Mike Fallenstein, I/O Configuration
Mark Olson, IBM eServer iSeries Brand Manager
- ▶ For project coordination and other help:
Ian Jarman
- ▶ For input on hardware or other products, as well as publishing assistance:

Jim Cook
Mark Gennrich
Thomas Gray
Randy Grimm
Duane Grosz
Charlie Jones
IBM Rochester

Mark Manges
Ray Perkins
Brian Podrow
Craig Schmitz
Fant Steele
Joe Writz
IBM Rochester

Aurora Ritter
Jesus Villarreal
IBM Austin

Mehboob H. Mithaiwala
IBM Dallas

Become a published author

Join us for a two- to six-week residency program! Help write an IBM Redbook dealing with specific products or solutions, while getting hands-on experience with leading-edge technologies. You'll team with IBM technical professionals, Business Partners and/or clients.

Your efforts will help increase product acceptance and client satisfaction. As a bonus, you'll develop a network of contacts in IBM development labs, and increase your productivity and marketability.

Find out more about the residency program, browse the residency index, and apply online at:

ibm.com/redbooks/residencies.html

Comments welcome

Your comments are important to us!

We want our Redbooks to be as helpful as possible. Send us your comments about this or other Redbooks in one of the following ways:

- ▶ Use the online **Contact us** review redbook form found at:

ibm.com/redbooks

- ▶ Send your comments in an Internet note to:

redbook@us.ibm.com

- ▶ Mail your comments to:

IBM Corporation, International Technical Support Organization
Dept. HYTD Mail Station P099
2455 South Road
Poughkeepsie, NY 12601-5400

Archived

IBM System i5, eServer i5 and iSeries upgrades

IBM System i5 and IBM eServer i5 Models 520, 550, 570, and 595, as well as iSeries Models 800, 810, 825, 870, and 890, support a large number of common I/O towers and I/O features. None of these models support SPD towers or expansion units which were used extensively with older models, such as the iSeries Models 720, 730, and 740 or earlier, or with the iSeries Models 820, 830, and 840 with the SPD migration tower.

Note: The #5065 Storage/PCI Expansion Tower is an SPD I/O tower.

The following table shows an overview of the supported upgrades for these System i models as of 1 June 2006.

Note: Although this redbook is based on January 2006 announcements, at the time of the latest publication, the authors have updated this table per announcements as of 1 June 2006.

From model	To model												
	520	520+	550	550+	570	570+	595	595 1.9GHz	800	810	825	870	890
Model 520	✓	✓											
Model 520+		✓											
Model 550				✓									
Model 550+													
Model 570					✓	✓	✓						
Model 570+						✓	✓						

From model	To model													
	520	520+	550	550+	570	570+	595	595 1.9GHz	800	810	825	870	890	
Model 595							✓	✓						
Model 595+								✓						
Model 800									✓*					
Model 810	✓	✓	✓	✓	✓	✓				✓*				
Model 825			✓	✓	✓	✓	✓				✓*	✓*		
Model 870					✓	✓	✓	✓				✓*	✓*	
Model 890					✓	✓	✓	✓					✓*	

* Effective 1 June 2006 upgrades from Models 800, 810, 825, 870, and 890 to Models 800, 810, 825, 870, and 890 are no longer available. Upgrades from Models 810, 825, 870, and 890 to Models 520, 550, 570, and 590 remain available.

The relationship between commercial processing workloads (CPWs) of the “from and to” systems varies depending on the ratio of batch to interactive workload. To determine the appropriate upgrade path, use the PATROL for iSeries – Predict (5620-FIF) or BEST/1 tool (part of 5722-PT1).

Note: BEST/1 is *withdrawn from marketing*. The latest modeling tools use PATROL for iSeries – Predict.

Refer to the Upgrade topic in the Find and Compare Tool (FACT) at the following Web site to determine the supported upgrade paths for a given processor:

<http://www-919.ibm.com/servers/eserver/fact/>

For software considerations, refer to “Software migration and upgrade paths” in *IBM System i5 Handbook*, SG24-7486. Use the IBM Prerequisite tool to find compatibility information for hardware and software features for supported System i processors. This tool is available at:

http://www-912.ibm.com/e_dir/eServerPrereq.nsf

1.1 Upgrades for System i processors

IBM eServer iSeries Migration: A Guide to Upgrades and Migrations to POWER Technology, SG24-7200, provides guidance for upgrading to eServer i5 Models 520, 550, 570, and 595. This redbook will be updated in 2006 to provide guidance for upgrading to the latest System i models.

Processor upgrades within IBM System i5 models are performed by IBM Service Representatives. Processor upgrades within and to IBM eServer i5 models are performed by IBM Service Representatives.

IBM eServer iSeries Migration: System Migration and Upgrades at V5R1 and V5R2, SG24-6055, provides guidance for upgrading to Models 800, 810, 820, 830, 840, 825, 870, and 890.

1.2 RISC-to-RISC Data Migration

The #0205 RISC-to-RISC Data Migration specify code is used when a client orders a new (RISC) System i5 server to replace an existing iSeries or AS/400e RISC-based system. The #0205 is ordered on the initial order of a Model 270, 520, 550, 570, 595, 800, 810, 820, 825, 830, 840, 870, or 890.

Manufacturing loads only the System Licensed Internal Code (SLIC) up through QSYS of i5/OS when the #0205 is ordered. Because of this limited loading of i5/OS by manufacturing, #5000 Software Preload Required is not allowed with the #0205. The #0205 RISC-to-RISC Data Migration and #5000 Software Preload Required are mutually exclusive.

Note: The #0205 RISC-to-RISC Data Migration specify code is *withdrawn from marketing* as of 01 April 2005 for machine type 9405.

Archived

IBM System i5 and eServer i5 models

This chapter provides the summary charts, diagrams, and identifies the processor features that are associated with each IBM System i5 and IBM eServer i5 Model 520, 550, 570, and 595. You can find feature descriptions, including details about power and packaging and main memory, in Chapter 4, “IBM System i5, eServer i5, and iSeries features and placement” on page 97.

In the 520 models without L3 cache, the POWER5 chip is packaged into a cost-effective Single Chip Module (SCM) package. In the Model 520 with L3 cache, and all Model 550 and 570 systems, the POWER5 chip is packaged with the L3 cache chip into a cost-effective Dual Chip Module (DCM) package. Each processor card has a single DCM containing a POWER5 processor chip and a 36 MB L3 module. A DCM and its associated L3 cache and memory are packaged on a single processor card.

More details regarding SCM and DCM can be found in the October 2005 edition of the *IBM eServer i5 and iSeries System Handbook i5/OS Version 5 Release 3 October 2005 - Draft*, GA19-5486.

Model and processor	Announce date	General availability date	Withdrawn from marketing
520 #8950, #8951, #8952, #8953, #8954, #8955	05 May 2004	31 May 2004	---
520 #8972	12 July 2005	22 July 2005	---
520+ #8325, #8327, #8330	31 January 2006	14 February 2006	---
550 #8958	17 August 2004	10 September 2004	---
550+ #8312	31 January 2006	14 February 2006	---
570 #8961	05 May 2004	31 May 2004	1 October 2004
570 #8971	30 July 2004	31 August 2004	---
570+ #8338	31 January 2006	14 February 2006	---

Model and processor	Announce date	General availability date	Withdrawn from marketing
595 #8981	15 October 2004	19 November 2004	---
595 #8966	31 January 2006	14 February 2006	---

Note: The darker shading in the following tables represents the base configuration of the system. The capacities shown might require prerequisites. Some combinations of features are not valid.

Archived

2.1 System i5 Model 520+ overview

The following tables provide the minimum and maximum system capacities for the Model 520+. The values are package dependent.

9405/9406 Model 520+										
Processor Feature	Server Feature	Configuration Feature ^{6a}	Processor/5250 CPW ⁵			MCU ^{2a}			LPAR	
			Base	with Accelerator ^{2b}	2-way with maximum 5250	Base	with Accelerator ^{2b}	2-way	Base	with Accelerator ^{2b}
#8325	#0970	#7140 Express	600/30	3100/30	-	-	6600	-	2	10
		#7141 Express	600/30	3100/30	-	-	6600	-	2	10
		#7142 Express	600/30	3100/30	-	-	6600	-	2	10
	#0975	#7350 Value	600/30	3100/30	-	-	6600	-	2	10
#8327	#0970	#7143 Express	1200/60	3800/60	-	2600	8200	-	3	10
		#7148 Express	1200/60	3800/60	-	2600	8200	-	3	10
		#7144 Express	3800/60	-	-	8200	-	-	10	-
		#7152 Express	3800/60	-	-	8200	-	-	10	-
	#0975	#7352 Value	1200/60	3800/60	-	2600	8200	-	3	10
	#0906	#7366 Solution	1200/max	-	-	2600	-	-	3	-
		#7373 High Availability	1200/max	-	-	2600	-	-	3	-
		#7374 High Availability	2800/max	-	-	6100	-	-	7	-
		#7734 Enterprise	1200/max	-	-	2600	-	-	3	-
		#7735 Enterprise	2800/max	-	-	6100	-	-	7	-
#7784 Standard		3800/0	-	-	8200	-	-	10	-	
#8330	#0906	#7375 High Availability	3800/3800	-	7100/7100	8200	-	15600	10/processor	
		#7736 Enterprise	3800/3800	-	7100/7100	8200	-	15600	10/processor	
		#7785 Standard	3800/0	-	7100/0	8200	-	15600	10/processor	

9405/9406 Model 520+			
Processor feature	#8325	#8327	#8330
Number/type/speed of processor	1/POWER5+/1.9 GHz	1/POWER5+/1.9 GHz	1/2-way/POWER5+ /1.9 GHz
L2 Cache (MB)	1.9	1.9	1.9
L3 Cache (MB)	0	36	36
Main storage (GB min/max)	1/32	1/32	1/32
Main storage DIMMs (min/max)	2/8	2/8	2/8
Minimum i5/OS / LIC level	V5R3 / V5R3M5	V5R3 / V5R3M5	V5R3 / V5R3M5
Software group ^{6a}	P05	P10	P20

To review the footnotes for this tables, see 2.7, “Notes for System i5 and eServer i5 Models 520, 550, 570, and 595” on page 21.

Archived

2.2 eServer i5 Model 520 overview

The following tables provide the minimum and maximum system capacities for the Model 520. The values are package dependent.

	9405 Model 520		
Processor feature	#8950	#8951	#8972
Server feature ⁹	#0900	#0901	#0912
Number/type/speed of processor	1/POWER5/ 1.5 GHz	1/POWER5/ 1.5 GHz	1/POWER5/ 1.5 GHz
Relative system performance ^{1, 2}			
Processor CPW	500	1000	2400
Mail and Calendar Users ^{2a, 9}	-	-	5500
5250 CPW ⁵			
Express ^{6a}	30	60	60
L2 Cache (MB)	1.88	1.88	1.88
L3 Cache (MB)	0	0	0
Main storage (GB min/max)	1/32	2/32	4/32
Main storage DIMMs (minimum/maximum)	4/8	4/8	4/8
Logical partitions (LPAR)	2	4	10
Minimum i5/OS level ^{8a}	V5R3	V5R3	V5R3
Software group ^{6a}	P05	P10	P10

	9406 Model 520						
Processor feature	#8950	#8951	#8952	#8953	#8954	#8955	#8972
Server feature ⁹	#0900	#0901	#0902	#0903	#0904	#0905	#0912
Number/ type/ speed of processor	1/ POWER5/ 1.5 GHz	1/ POWER5/ 1.5 GHz	1/ POWER5/ 1.5 GHz	1 /POWER5/ 1.5 GHz	1/ POWER5/ 1.65 GHz	2/ POWER5/ 1.65 GHz	1/ POWER5/ 1.5 GHz
Relative system performance ^{1, 2}							
Processor CPW	500	1000	1000	2400	3300	6000	2400
Mail and Calendar 5250 CPW ⁵	---	2300	2300	5500	7300	13300	5500
Value ^{6a}	30	60	-	-	-	-	60
Express ^{6a}	-	60	-	-	-	-	60
Standard ^{6a}	-	-	0	0	0	0	-
Solution ^{6a}	-	-	1000	-	-	-	-
Enterprise ^{6a}	-	-	1000	2400	3300	6000	-
High Availability ^{6a}	-	-	1000	2400	3300	6000	-
L2 Cache (MB)	1.88	1.88	1.88	1.88	1.88	1.88	1.88
L3 Cache (MB)	0	0	0	0	36	36	0
Main storage (GB min/max)	0.5/32	1/32	1/32	1/32	1/32	1/32	1/32
Main storage DIMMs (minimum/maximum)	2/8	4/8	4/8	4/8	4/8	4/8	4/8
Logical partitions (LPAR)	2	4	4	10	10	20	10
Minimum i5/OS level	V5R3	V5R3	V5R3	V5R3	V5R3	V5R3	V5R3
Software group ^{6a}	P05	P10	P10	P10	P20	P20	P10

Numbers are for all 9405 and 9406 520/520+ processor features	Base system unit	System maximum
Disk storage (GB)		
Integrated minimum ^{7b}	0	
Integrated maximum ^{7a}	1109	39234
Total maximum ^{7, 7a}	-	39234
DASD arms maximum	8	278
Internal arms	8	278
External LUNs	-	278
Physical packaging		
Rack design - EIA units	4	4
External RIO-G ports	0/2	2
External RIO-G loops	0/1	1
PCI/PCI-X Expansion Tower	6	6
External xSeries® Servers	8	8
PCI card slots ^{10a}	6	90
Communication lines ³	8	192
LAN ports (includes embedded)	5	36
Integrated xSeries Servers	1	18
Twinaxial workstation controllers	3	48
Twinaxial workstations	120	1920
Internal tape/CD/DVD ⁴	1 tape / 2 DVD	13 tapes / 14 CD/DVD
External tape/optical/CD/DVD (single partition maximum)	0	18
External tape/optical/CD/DVD (system maximum)	0	36
Cryptographic coprocessor	0	8
Cryptographic accelerator	0	2

To review the footnotes for this table, see 2.7, “Notes for System i5 and eServer i5 Models 520, 550, 570, and 595” on page 21.

2.3 System i5 Model 550+ and eServer i5 Model 550 overview

The following tables provide the minimum and maximum system capacities for the Models 550+ and 550. The values are package dependent.

	Model 550	Model 550+
Processor feature	#8958	#8312
Server feature ⁹	#0915	#0910
Number/type/speed of processor	1/4/POWER5/1.65 GHz	1/4/POWER5+/1.9 GHz
Relative system performance ^{1, 2}		
Processor CPW	3300/12000	3800/14000
Mail and Calendar Users ^{2a, 9}	7300/26600	8200/30000
5250 CPW ⁵		
Standard ^{6b}	0	0
Enterprise ^{6b}	Maximum	Maximum
High Availability ^{6b}	Maximum	Maximum
Domino@ ^{6b}	0	0
Solution ^{6b}	Maximum	Maximum
Solution Edition for Oracle JDE Enterprise One ^{6b}	Maximum	Maximum
C2CRM with Domino ^{6b}	Maximum	Maximum
2-way SAP ^{6b}	0	0
4-way SAP ^{6b}	0	0
L2 Cache (MB)	1.9	1.9
L3 Cache (MB)	36	36
Main storage (GB min/max)	2/64	2 /64
Main storage DIMMs (minimum/maximum)	4/16	4/16
LPAR	10-40	10-40
Minimum i5/OS level	V5R3	V5R3
Software group ^{6b}	P20	P20

Numbers are for all 550+ and 550 processor features	Base system unit	System maximum
Disk storage (GB)		
Integrated minimum ^{7b}	0	0
Integrated maximum ^{7a}	1128	77051
Total maximum ^{7,7a}	-	77051
DASD arms maximum		
Internal arms	8	548
External LUNs	-	548
Physical packaging		
Rack design - EIA units	4	4
External RIO-G ports	2	4
External RIO-G loops	1	2
PCI/PCI-X Expansion Tower	6	12
External xSeries Servers	8	16
PCI card slots ¹⁰	5	172
Communication lines ³	6	320
LAN ports (includes embedded)	5	96
Integrated xSeries Servers	1	36
Twinaxial workstation controllers	2	133
Twinaxial workstations	80	5320
Internal CD/DVD/tape ⁴	2	26
External tape/optical/CD/DVD (LPAR)	2 (2)	18 (36)
Cryptographic coprocessor	1	8
Cryptographic accelerator	1	4

To review the footnotes for this table, see 2.7, "Notes for System i5 and eServer i5 Models 520, 550, 570, and 595" on page 21.

2.4 System i5 Model 570+ overview

The following tables provide the minimum and maximum system capacities for the Model 570+. The values are package dependent.

Processor feature	Model 570+			
	#8338 x 2	#8338 x 4	#8338 x 8	#8338 x 8
Server feature	#0934	#0935	#0936	#0937
Number/ type/ speed of processor	2/4/ POWER5+/ 2.2 GHz	4/8/ POWER5+/ 2.2 GHz	8/16/ POWER5+/ 2.2 GHz	2/16/ POWER5+/ 2.2 GHz
Relative system performance ^{1, 2}				
Processor CPW	8400/16000	16700/31100	31100/58500	8100/58500
Mail and Calendar Users ^{2a, 9}	18200/34500	35500/67500	67500/130000	18200/130000
5250 CPW ⁵				
Standard ^{6c}	0	0	0	0
Enterprise ^{6c}	Maximum	Maximum	Maximum	-
High Availability ^{6c}	Maximum	Maximum	Maximum	-
Capacity BackUp ^{6c}	-	-	-	Maximum
L2 Cache (MB) per processor	1.9	1.9	1.9	1.9
L3 Cache (MB) per processor	36	36	36	36
Main storage (GB minimum/maximum)	4/128	8/256	16/512	16/512
Main storage DDR2 DIMMs (minimum/maximum)	8/16	16/32	32/64	32/64
Logical partitions (LPAR) ¹²	20/40	40/80	80/160	20/160
Minimum i5/OS level ⁸	V5R3	V5R3	V5R3	V5R3
Software group ^{6c}	P30	P40	P40	P40
Disk storage (GB)				
Integrated minimum ^{7b}	0	0	0	0
Total maximum ^{7a}	77051	116000	193898	193898
DASD arms maximum	546	822	1374	1374
Internal arms	546	822	1374	1374
External LUNs	546	822	1374	1374
Physical packaging				
Rack Design - EIA units	4	8	16	16
External RIO-G ports	4	8	16	16
External RIO-G loops	2	4	8	8
PCI/PCI-X Expansion Tower	12	24	48	48
External xSeries Servers (IXA)	16	32	57	57
PCI card slots ¹⁰	173	346	692	695
Communication lines ³	320	480	480	480
LAN ports (includes embedded)	96	128	128	128
Integrated xSeries Servers	36	48	48	48
Twinaxial workstation controllers	134	180	180	180
Twinaxial workstations	5360	7200	7200	7200
Internal DVD-ROM/ DVD-RAM ⁴	1	2	4	4
Internal CD-ROM/Tape	0	0	0	0
Feature I/O Tower Tape/CD-ROM/DVD (combined system partition)	18 (25)	26 (36)	26 (48)	26 (48)

	Model 570+			
Processor feature	#8338 x 2	#8338 x 4	#8338 x 8	#8338 x 8
Server feature	#0934	#0935	#0936	#0937
External tape (combined system partition)	18 (36)	26 (48)	26 (48)	26 (48)
External optical/CD/DVD (combined system partition)	26 (48)	26 (48)	26 (48)	26 (48)
Cryptographic coprocessor (combined system partition)	8 (32)	8 (32)	8 (32)	8 (32)
Cryptographic accelerator (combined system partition)	4 (8)	4 (8)	4 (8)	4 (8)

To review the footnotes for this table, see 2.7, “Notes for System i5 and eServer i5 Models 520, 550, 570, and 595” on page 21.

Archived

2.5 eServer i5 Model 570 overview

The following tables provide the minimum and maximum system capacities for the Model 570. The values are package dependent.

Processor feature	Model 570	
	#8961	#8961 (x2)
Server feature	#0919	#0920
Number / type / speed of processor	0/2 / POWER5/1.65 GHz	2/4 /POWER5/1.65 GHz
Relative system performance ^{1, 2}		
Processor CPW	3300/6000	6350/12000
Mail and Calendar Users ^{2a, 9}	7300/13300	14100/26600
5250 CPW ⁵		
Standard ^{6c}	0	0
Enterprise ^{6c}	Maximum	Maximum
L2 Cache (MB per processor)	1.9	1.9
L3 Cache (MB per processor)	36	36
Main storage (GB minimum/maximum)	2/65	2/128
Main storage DIMMs (minimum/maximum)	4/8	8/16
Logical partitions (LPAR) ¹²	10/20	20/40
Minimum i5/OS level ⁸	V5R3	V5R3
Software group ^{6c}	P30	P30
Disk storage (GB)		
Integrated minimum ^{7b}	0	0
Total maximum ^{7a}	38949	77051
DASD arms maximum	276	546
Internal arms	276	546
External LUNs	276	546
Physical packaging		
Rack design - EIA units	4	4
External RIO-G ports	2	4
External RIO-G loops	1	2
PCI/PCI-X Expansion Tower	6	12
External xSeries Servers (IXA)	8	16
PCI card slots ¹⁰	90	173
Communication lines ³	278	320
LAN ports (includes embedded)	71	96
Integrated xSeries Servers	19	36
Twinaxial workstation controllers	69	133
Twinaxial workstations	2760	5360
Internal DVD-ROM/ DVD-RAM ⁴	1	1
Internal CD-ROM/Tape	0	0
I/O Tower Tape/CD-ROM/DVD	13 (13)	18 (25)
External tape (LPAR)	18 (36)	18 (36)
External optical/CD/DVD (LPAR)	26 (48)	26 (48)
Cryptographic coprocessor (combined system partition)	8	8
Cryptographic accelerator (combined system partition)	4 (8)	4 (8)

Model 520, 550,
570, 595

	Model 570					
Processor feature	#8971	#8971 x 2	#8971 x 4	#8971 x 6	#8971 x 8	#8971
Server feature	#0930	#0921	#0922	#0924	#0926	#0928
Number/ type/ speed of processor	1/2/ POWER5/ 1.65 GHz	2/4/ POWER5/ 1.65 GHz	5/8/ POWER5/ 1.65 GHz	9/12/ POWER5/ 1.65 GHz	13/16/ POWER5/ 1.65 GHz	2/16/ POWER5/ 1.65 GHz
Relative system performance ^{1, 2}						
Processor CPW	3300/6000	6350/12000	15200/25500	25500/33400	36300/44700	6350/44700
Mail and Calendar Users ^{2a, 9}	14100/ 26600	14100/25900	33600/52500	57300/77000	83600/102000	14100/102000
5250 CPW ⁵						
Standard ^{6c}	0	0	0	0	0	0
Enterprise ^{6c}	Maximum	Maximum	Maximum	Maximum	Maximum	-
High Availability ^{6c}	Maximum	Maximum	Maximum	Maximum	Maximum	-
Capacity BackUp ^{6c}	Maximum	-	-	-	-	Maximum
L2 Cache (MB) per processor	1.9	1.9	1.9	1.9	1.9	1.9
L3 Cache (MB) per processor	36	36	36	36	36	36
Main storage (GB minimum/maximum)	2/64	4/128	8/256	12/384	16/512	16/512
Main storage DIMMs (minimum/maximum)	4/8	8/16	16/32	24/48	32/64	32/64
Logical partitions (LPAR) ¹²	10/20	20/40	50/80	90/120	120/160	20/160
Minimum i5/OS level ⁸	V5R3	V5R3	V5R3	V5R3	V5R3	V5R3
Software group ^{6c}	P30	P30	P40	P40	P40	P40
Disk storage (GB)						
Integrated minimum ^{7b}	0	0	0	0	0	0
Total maximum ^{7a}	38949	77051	116000	154949	193898	193898
DASD arms maximum	276	546	822	1098	1374	1374
Internal arms	276	546	822	1098	1374	1374
External LUNs	276	546	822	1098	1374	1374
Physical packaging						
Rack Design - EIA units	4	4	8	12	16	16
External RIO-G ports	2	4	8	12	16	16
External RIO-G loops	1	2	4	6	8	8
PCI/PCI-X Expansion Tower	6	12	24	36	48	48
External xSeries Servers (IXA)	8	16	32	48	57	57
PCI card slots ¹⁰	90	173	346	519	692	692
Communication lines ³	278	320	480	480	480	480
LAN ports (includes embedded)	52	96	128	128	128	128
Integrated xSeries Servers	19	36	48	48	48	48
Twinaxial workstation controllers	69	134	180	180	180	180
Twinaxial workstations	2760	5360	7200	7200	7200	7200
Internal DVD-ROM/ DVD-RAM ⁴	1	1	2	3	4	4
Internal CD-ROM/Tape	0	0	0	0	0	0
Feature I/O Tower Tape/CD-ROM /DVD (combined system partition)	13 (13)	18 (25)	26 (36)	26 (48)	26 (48)	26 (48)

	Model 570					
Processor feature	#8971	#8971 x 2	#8971 x 4	#8971 x 6	#8971 x8	#8971
Server feature	#0930	#0921	#0922	#0924	#0926	#0928
External tape (LPAR) (combined system partition)	18 (36)	18 (36)	26 (48)	26 (48)	26 (48)	26 (48)
External optical/CD/DVD (combined system partition)	26 (48)	26 (48)	26 (48)	26 (48)	26 (48)	26 (48)
Cryptographic coprocessor (combined system partition)	8 (32)	8 (32)	8 (32)	8 (32)	8 (32)	8 (32)
Cryptographic accelerator (combined system partition)	4 (8)	4 (8)	4 (8)	4 (8)	4 (8)	4 (8)

To review the footnotes for this table, see 2.7, “Notes for System i5 and eServer i5 Models 520, 550, 570, and 595” on page 21.

2.6 System i5 and eServer i5 Model 595 overview

The following tables provide the minimum and maximum system capacities for the Model 595. The values are package dependent.

Model 595				
Processor feature	#8966	#8966 x 2	#8966 x 4	#8966 x 2
Server feature	#0940	#0941	#0943	#0944
Number/type/speed of processor	8/16 /POWER5/1.9 GHz	16/32 /POWER5/1.9 GHz	32/64 /POWER5/1.9 GHz	4/32/POWER5/1.9 GHz
Relative system performance ^{1, 2}				
Processor CPW	26700/50500	51000/92000	92000/184000	13600/92000
Mail and Calendar Users ^{2a, 9}	60500/114000	115000/213000 ^{2c}	213000/405000 ^{2c}	31500/213000 ^{2c}
5250 CPW ⁵				
Standard ^{6d}	0	0	0	0
Enterprise ^{6d}	Maximum	Maximum	Maximum	-
High Availability ^{6d}	Maximum	Maximum	Maximum	-
Capacity BackUp ⁶	-	-	-	Maximum
L2 Cache (MB per processor) MCM	1.9	1.9	1.9	1.9
L3 Cache (MB per processor) MCM	36	36	36	36
Main storage (GB minimum/maximum) ¹¹	8/512	16/1024	32/2048	16/1024
Main storage DIMMs (minimum/maximum)	4/16	4/32	4/64	4/32
Logical partitions (LPAR) ¹²	160	254	254	254
Minimum i5/OS level ⁸	V5R3	V5R3	V5R3	V5R3
Software group ^{6d}	P50	P50	P60	P50
Disk storage (GB)				
Integrated minimum ^{7b}	0	0	0	0
Total maximum ^{7a}	228614	381024	381024	381024
DASD arms maximum ^{7c}	1620	2700	2700	2700
Internal arms	1620	2700	2700	2700
External LUNs	1620	2700	2700	2700
Physical packaging ¹³				
Rack design - EIA units	18	18	18	18
External RIO-G ports	14	30	62	30
External RIO-G loops ^{10b}	7	15	31	15
PCI/PCI-X Expansion Tower	36	72	96	72
External xSeries Servers (IXA)	48	57	57	57
PCI card slots ¹⁰	504	1008	1152	1008
Communication lines ³	600	600	600	600
LAN ports (includes embedded)	160	160	160	160
Integrated xSeries Servers	60	60	60	60
Twinaxial workstation controllers	180	180	180	180
Twinaxial workstations	7200	7200	7200	7200
Internal DVD-ROM/DVD-RAM ⁴	2	2	2	2
Internal CD-ROM/Tape	0	0	0	0
Feature I/O Tower Tape/CD-ROM/DVD (combined system partition)	26 (60)	26 (60)	26 (60)	26 (60)
External tape (combined system partition)	26 (60)	26 (60)	26 (60)	26 (60)
External optical/CD/DVD (combined system partition)	26 (60)	26 (60)	26 (60)	26 (60)

Cryptographic coprocessor (combined system partition)	8 (32)	8 (32)	8 (32)	8 (32)
Cryptographic accelerator (combined system partition)	4 (16)	4 (16)	4 (16)	4 (16)

Processor feature	Model 595		
	#8981	#8981 x 2	#8981 x 4
Server feature	#0946	#0947	#0952
Number/type/ speed of processor	8/16 /POWER5/ 1.65 GHz	16/32 /POWER5/ 1.65 GHz	32/64 /POWER5/ 1.65 GHz
Relative system performance ^{1, 2}			
Processor CPW	24500/45500	46000/85000	86000/165000
Mail and Calendar Users ^{2a, 9}	104000	194000	375000
5250 CPW ⁵			
Standard ^{6d}	0	0	0
Enterprise ^{6d}	Maximum	Maximum	Maximum
High Availability ^{6d}	Maximum	Maximum	Maximum
Capacity BackUp ⁶	-	-	-
L2 Cache (MB per processor) MCM	1.9	1.9	1.9
L3 Cache (MB per processor) MCM	36	36	36
Main storage (GB minimum/maximum) ¹¹	8/512	16/1024	32/2048
Main storage DIMMs (minimum/maximum)	4/16	4/32	4/64
Logical partitions (LPAR) ¹²	160	254	254
Minimum i5/OS level ⁸	V5R3	V5R3	V5R3
Software group ^{6d}	P50	P50	P60
Disk storage (GB)			
Integrated minimum ^{7b}	0	0	0
Total maximum ^{7a}	228614	381024	381024
DASD arms maximum ^{7c}			
Internal arms	1620	2700	2700
External LUNs	1620	2700	2700
Physical packaging			
Rack design - EIA units ¹³	18	18	18
External RIO-G ports	14	30	62
External RIO-G loops ^{10b}	7	15	31
PCI/PCI-X Expansion Tower	36	72	96
External xSeries Servers (IXA)	48	57	57
PCI card slots ¹⁰	504	1008	1152
Communication lines ³	600	600	600
LAN ports (includes embedded)	160	160	160
Integrated xSeries Servers	60	60	60
Twinaxial workstation controllers	180	180	180
Twinaxial workstations	7200	7200	7200
Internal DVD-ROM/DVD-RAM ⁴	2	2	2
Internal CD-ROM/Tape	0	0	0
Feature I/O Tower Tape/CD-ROM/DVD (combined system partition)	26 (60)	26 (60)	26 (60)
External tape (combined system partition)	26 (60)	26 (60)	26 (60)
External optical/CD/DVD (combined system partition)	26 (60)	26 (60)	26 (60)
Cryptographic coprocessor (combined system partition)	8 (32)	8 (32)	8 (32)

Cryptographic accelerator (combined system partition)	4 (16)	4 (16)	4 (16)
--	--------	--------	--------

To review the footnotes for this table, see 2.7, “Notes for System i5 and eServer i5 Models 520, 550, 570, and 595” on page 21.

2.7 Notes for System i5 and eServer i5 Models 520, 550, 570, and 595

Note 1	Commercial Processing Workload (CPW) is used to measure the performance of all System i5 (iSeries and AS/400e) processors announced from September 1996 onward. The CPW value is measured on maximum configurations. The type and number of disk devices, the number of workstation controllers, the amount of memory, the system model, other factors, and the application running determine what performance is achievable.
Note 2	Processor performance represents the relative performance (maximum capacity) of a processor feature running CPW in a client/server environment. Processor capacity is achievable when the commercial workload is not constrained by main storage and direct access storage device (DASD). Performance of the 5250 CPW represents the relative performance available to perform host-centric workloads. The amount of 5250 CPW capacity consumed reduces the available processor capacity by the same amount.
Note 2a	Mail and Calendar Users (MCU) is a relative performance measurement derived by performing mail and calendar functions using Domino and Notes clients. The MCU workload represents users on a Notes client who are reading, updating or deleting documents in an e-mail database. It also represents users who are performing lookups in the Domino directory and scheduling calendar appointments and invitations. Reported values reflect 70% processor utilization to allow for growth and peak loads in excess of customer workload estimates. Domino and Notes Mail and Calendar use is not recommended on Model 520 #8325 processors.
Note 2b	The optional Accelerator for System i5 feature provides a dramatic boost in processor CPW for additional workloads and partitions.
Note 2c	The MCU rating is a projected value.
Note 3	One line is used if #5544 System Console on Operations Console is used. One line can be used if #5546 System Console on 100 Mbps Token Ring or #5548 System Console on 100 Mbps Ethernet is selected and the #0367 Operations Console PCI Cable must be connected. The numbers include the ECS line.
Note 4	There must be one DVD-ROM or DVD-RAM per system. For Models 870 and 890, there must be one DVD-RAM or DVD-ROM in the #9094 Base PCI I/O Enclosure.
Note 5	5250 CPW (Interactive) is an approximate value that reflects the amount of Processor CPW that can be used for workloads performing 5250-based tasks. Remember that: <ul style="list-style-type: none"> ▶ The iSeries Enterprise Edition provides maximum 5250 CPW support (up to 100% of the capacity of the active processor CPW). ▶ The iSeries Standard Edition provides zero CPW for 5250 work. Limited 5250 CPW is available for a system administrator to use 5250 display device I/O to manage various aspects of the server. Multiple administrative jobs exceed this capability. ▶ A task submitted through a 5250 session (5250 device or 5250 emulation) that does display or printer I/O requires 5250 CPW. ▶ A task submitted through a 5250 session (5250 device or 5250 emulation) as a "batch" job is not considered 5250 OLTP work and does not require any 5250 CPW unless the task does display or printer I/O. ▶ Maximum 5250 CPW is equivalent to the Processor CPW for the active processor.

**Note 6a
Models
520+ 520**

Software group is determined by the combination of processor feature and edition feature. Display the QPRCFEAT system value or DSPHDWRSC TYPE(*AHW) to display the processor feature code value. This value is also shown for the Capacity Card CCIN value when using SST to perform a Capacity Upgrade on Demand. The following table provides a cross reference.

Processor	Server feature	Edition/configuration feature	Software group	Processor feature code or QPRCFEAT value
#8325	#0970	#7140 Express	P05	7140
		#7141 Express	P05	7141
		#7142 Express	P05	7142
	#0975	#7350 Value	P05	7350
#8327	#0970	#7143 Express	P10	7143
		#7144 Express	P10	7144
		#7148 Express	P10	7148
		#7152 Express	P10	7152
	#0975	#7352 Value	P10	7352
	#0906	#7784 Standard	P10	7784
		#7734 Enterprise	P10	7734
		#7735 Enterprise	P10	7735
		#7373 High Availability	P10	7373
		#7374 High Availability	P10	7374
		#7366 Solution	P10	7366
#8330	#0906	#7785 Standard	P20	7785
		#7736 Enterprise	P20	7736
		#7375 High Availability	P20	7375
#8950	#0900	#7390 Express	P05	7390
		#7391 Express	P05	7391
		#7393 Express	P05	7393
		#7411 Express	P05	7411
		#7413 Express	P05	7413
		#7417 Express	P05	7417
		#7450 Value	P05	7450

Note 6a Models 520+ 520 (cont.)	#8951	#0901	#7392 Express	P05	7392
			#7394 Express	P10	7392
			#7414 Express	P10	7414
			#7420 Express	P10	7420
			#7451 Value	P10	7451
	#8952	#0902	#7458 Standard	P10	7458
			#7459 Enterprise	P10	7459
			#7541 Solution	P10	7541
			#7552 High Availability	P10	7459
	#8953	#0903	#7452 Standard	P10	7452
			#7453 Enterprise	P10	7453
			#7553 High Availability	P10	7453
	#8954	#0904	#7454 Standard	P20	7454
			#7455 Enterprise	P20	7455
			#7554 High Availability	P20	7455
	#8955	#0905	#7456 Standard	P20	7456
			#7457 Enterprise	P20	7457
			#7555 High Availability	P20	7457
	#8972	#0912	#7395 Express	P10	7395
			#7396 Express	P10	7395
#7397 Value			P10	7397	

Note 6b Models 550+ 550	Software group is determined by the combination of processor feature and edition feature. Display the QPRCFEAT system value or DSPHDWRSC TYPE(*AHW) to display the processor feature code value. This value is also shown for the Capacity Card CCIN value when using SST to perform a Capacity Upgrade on Demand. The following table provides a cross reference.				
	Processor	Server feature	Edition feature	Software group	Processor feature code or QPRCFEAT value
	#8312	#0910	#7154 Standard	P20	7154
			#7155 Enterprise	P20	7155
			#7551 High Availability	P20	7551
			#7629 Domino	P20	7629
			#7630 Solution	P20	7630
			#7631 Oracle JDE Enterprise One	P20	7631
			#7632 C2CRM	P20	7632
			#7640 2-way SAP	P20	7640
#7641 4-way SAP			P20	7641	

Note 6b Models 550+ 550 (cont.)	#8958	#0915	#7462 Standard	P20	7462
			#7463 Enterprise	P20	7463
			#7530 Domino	P20	7462
			#7558 Solution	P20	7463
			#7531 Solution Edition for PeopleSoft Enterprise One	P20	7463
			#7532 C2CRM Solution Edition with Domino	P20	7463
			#7533 2-way SAP Solution Edition	P20	7462
			#7534 4-way SAP Solution Edition	P20	7462
Note 6c Models 570+ 570	Software group is determined by the combination of processor feature and edition feature. Display the QPRCFEAT system value or DSPHDWRSC TYPE(*AHW) to display the processor feature code value. This value is also shown for the Capacity Card CCIN value when using SST to perform a Capacity Upgrade on Demand. The following table provides a cross reference.				
	Processor	Server feature	Edition feature	Software group	Processor feature code or QPRCFEAT value
	#8338	#0934	#7757 Standard	P30	7757
			#7747 Enterprise	P30	7747
			#7763 High Availability	P30	7763
		#0935	#7758 Standard	P40	7758
			#7748 Enterprise	P40	7748
			#7764 High Availability	P40	7764
		#0936	#7759 Standard	P40	7759
			#7749 Enterprise	P40	7749
			#7765 High Availability	P40	7765
	#0937		#7760 Capacity BackUp	P30	7760
	#8961	#0919	#7488 Standard	P30	7450
			#7489 Enterprise	P30	7451
		#0920	#7469 Standard	P30	7458
#7470 Enterprise			P30	7459	

Note 6c Models 570+ 570 (cont.)	#8971	#0921	#7494 Standard	P30	7494
			#7495 Enterprise	P30	7495
			#7560 High Availability	P30	7495
		#0922	#7471 Standard	P40	7441
			#7472 Enterprise	P40	7472
			#7561 High Availability	P40	7472
		#0924	#7473 Standard	P40	7473
			#7474 Enterprise	P40	7474
			#7562 High Availability	P40	7474
	#0926	#7475 Standard	P40	7475	
		#7476 Enterprise	P40	7476	
		#7563 High Availability	P40	7476	
	#0928	#7570 Capacity BackUp	P40	7570	
	#0930	#7490 Standard	P30	7490	
		#7491 Enterprise	P30	7491	
#7559 High Availability		P30	7491		

Note 6d Model 595	Software group is determined by the combination of processor feature and edition feature. Display the QPRCFEAT system value or DSPHDWRSC TYPE(*AHW) to display the processor feature code value. This value is also shown for the Capacity Card CCIN value when using SST to perform a Capacity Upgrade on Demand. The following table provides a cross reference.				
	Processor	Server feature	Edition feature	Software group	Processor feature code or QPRCFEAT value
#8966	#0940	#7480 Standard	P50	7480	
		#7481 Enterprise	P50	7481	
		#7580 High Availability	P50	7481	
	#0941	#7482 Standard	P50	7482	
		#7483 Enterprise	P50	7483	
		#7581 High Availability	P50	7483	
	#0943	#7486 Standard	P60	7486	
		#7487 Enterprise	P60	7487	
		#7583 High Availability	P60	7487	
#0944	#7590 Capacity BackUp	P50	7590		
#8981	#0946	#7496 Standard	P50	7496	
		#7497 Enterprise	P50	7497	
	#0947	#7498 Standard	P50	7498	
		#7499 Enterprise	P50	7499	
	#0952	#7984 Standard	P60	7984	
		#7985 Enterprise	P60	7985	

Note 7	External DASD cannot exceed the maximum system capacity or the maximum number of disk arms.
Note 7a	Total maximum DASD capacity assumes 141.12 GB disk drives, which were announced in July 2005. External DASD cannot exceed the maximum system capacity or the maximum number of disk arms.
Note 7b	With the announcement of SAN Boot there is no longer a requirement for an internal disk. San Boot requires #2847 PCI IOP for SAN Load Source.
Note 7c	Maximum of 2000 DASD arms in a single i5/OS partition.
Note 8	i5/OS V5R3 and LIC V5R3M5 with the latest level of LIC and Cumulative PTF package available for the IBM System i5 520+ with a 1.9 GHz processor. For the latest information, refer to: http://www-912.ibm.com/e_dir/eServerPrereq.nsf/UpgradeCategories/Hardware?opendocument
Note 8a	For Model 520 2-way processors shipped prior to 10 December 2004 that have keyed products installed, update the server firmware to accept the lower P20 software tier. See the following Web site for the latest HMC updates: http://techsupport.services.ibm.com/server/hmc/power5
Note 9	The server features used for iSeries for Domino specify the minimum amount of disk, memory, and Domino licenses required for an initial order.
Note 10	When a second RIO-G loop is required, one PCI card slot is used for the RIO-G adapter.
Note 10a	The 520+ models have one PCI-X 2.0 card slot (P1-C4) that is for IOP-less cards only
Note 10b	The use of more than 24 RIO-G loops (48 cables) requires physical planning, and careful cable placement and management. Closing the Model 595 door can be difficult.
Note 11	One terabyte (TB) of memory can be ordered after 28 October 2004. Two TB are available in 2005.
Note 12	A maximum of 64 i5/OS partitions applies.
Note 13	Rack containing the system unit is a 42U, 24-inch rack. The bulk power supplies are installed in 8U leaving 16U empty.

2.8 9405 and 9406 Models 520+ and 520 system unit schematics

2.8.1 Model 520+ top view

In the following schematic of the top view of the Model 520+, T5 is port 0 and T6 is port 1.

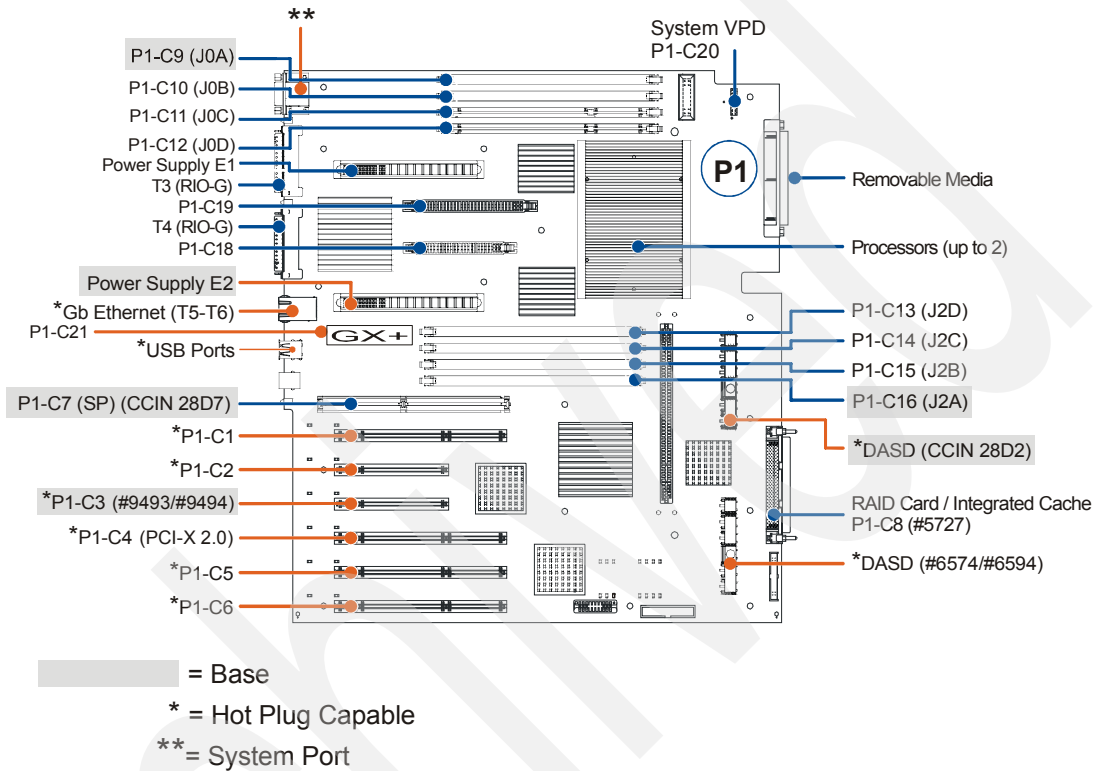

2.8.2 Model 520+ front view

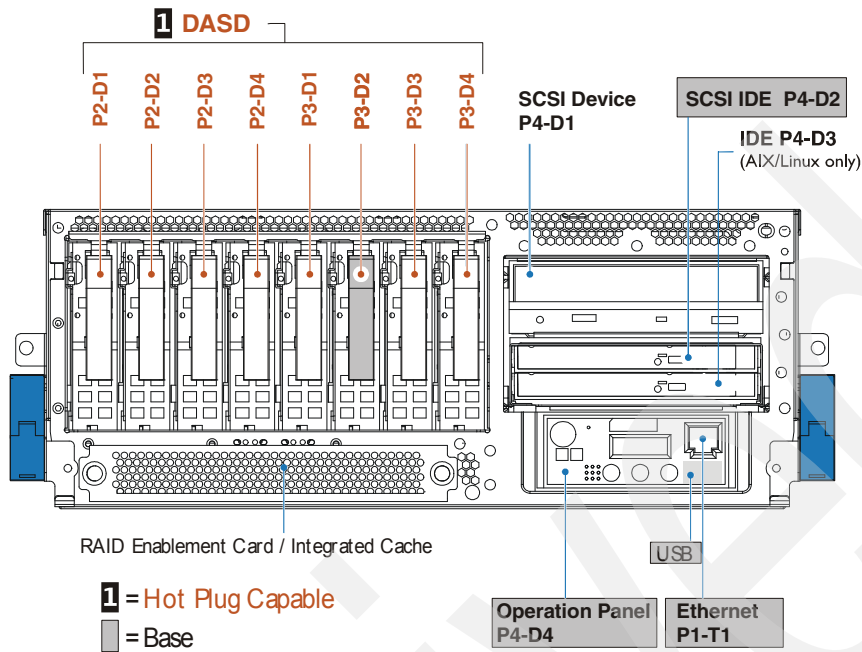

2.8.3 Model 520+ back view

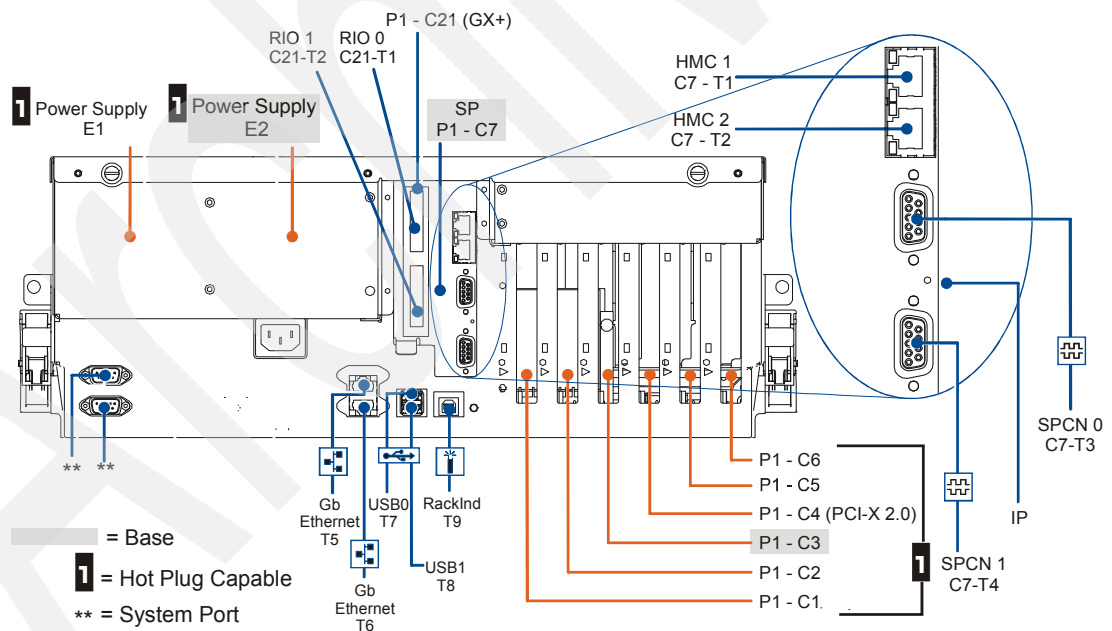

Note: An #1827 Serial-UPS Conversion Cable connects to the top system port on a rack mounted system or the right-hand system port on a desk side system. T5 is the default port 0 for the embedded LAN console.

2.8.4 Model 520 top view

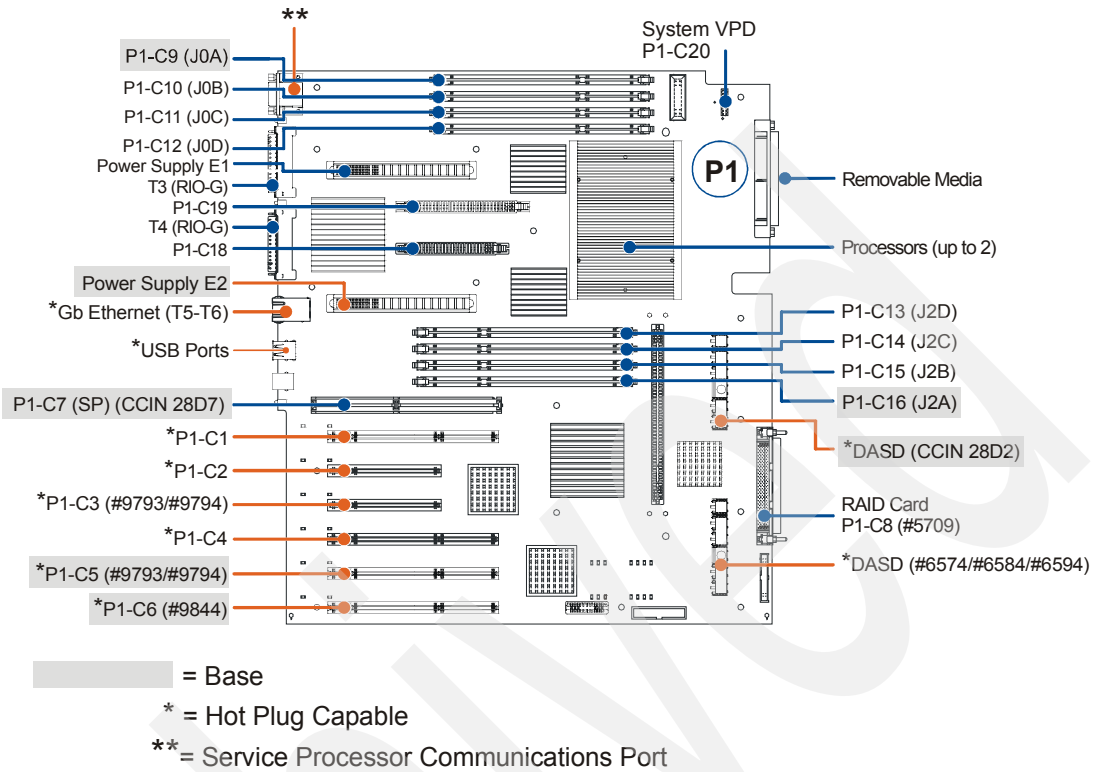

2.8.5 Model 520 front view

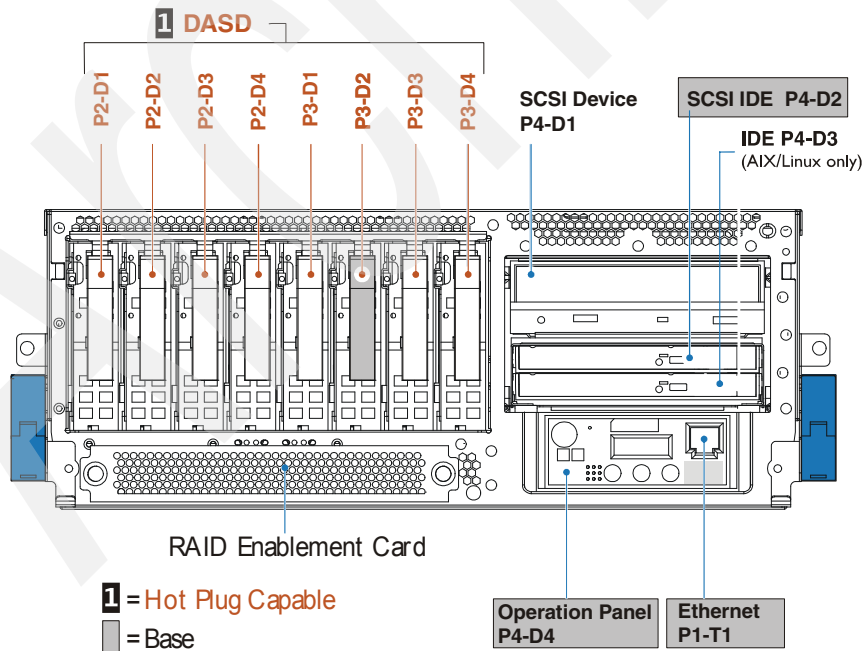

2.8.6 Model 520 back view

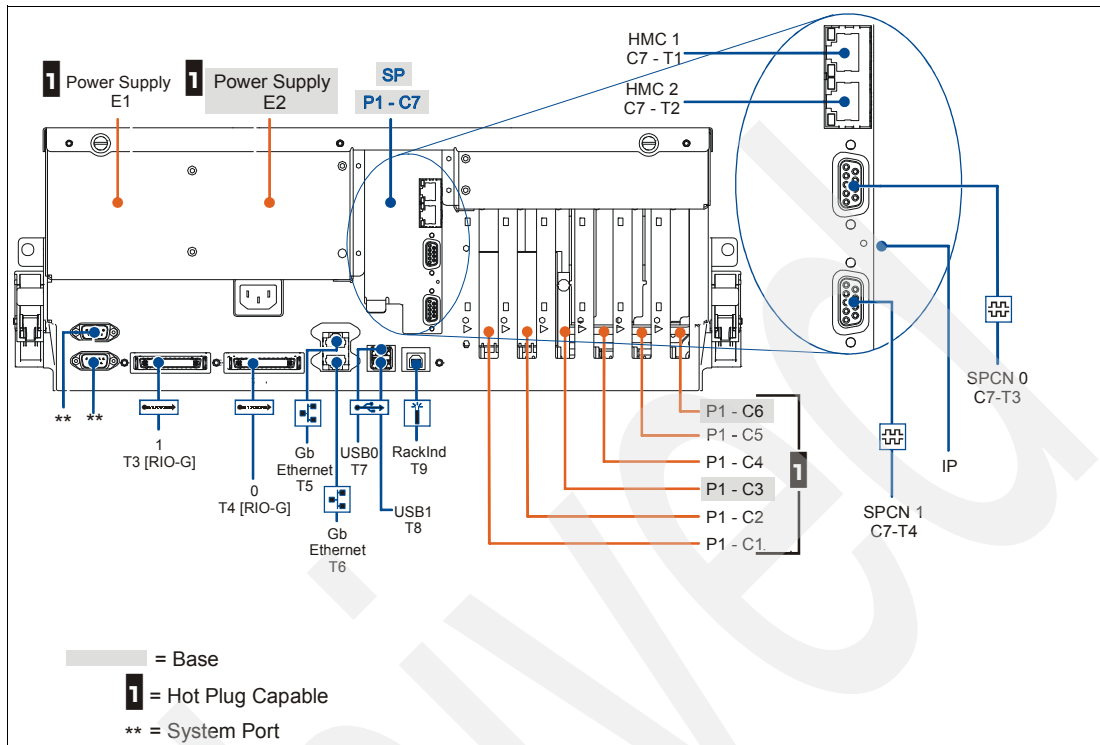

2.9 9406 Models 550+ and 550 system unit schematics

2.9.1 Models 550+ and 550 top view

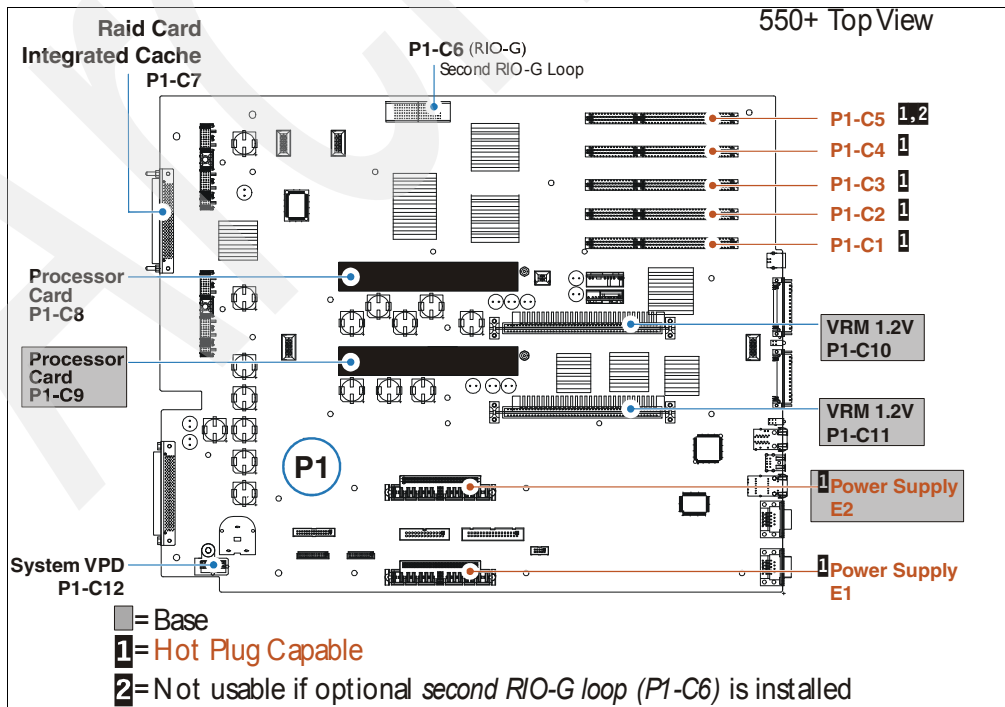

2.9.2 Models 550+ and 550 front view

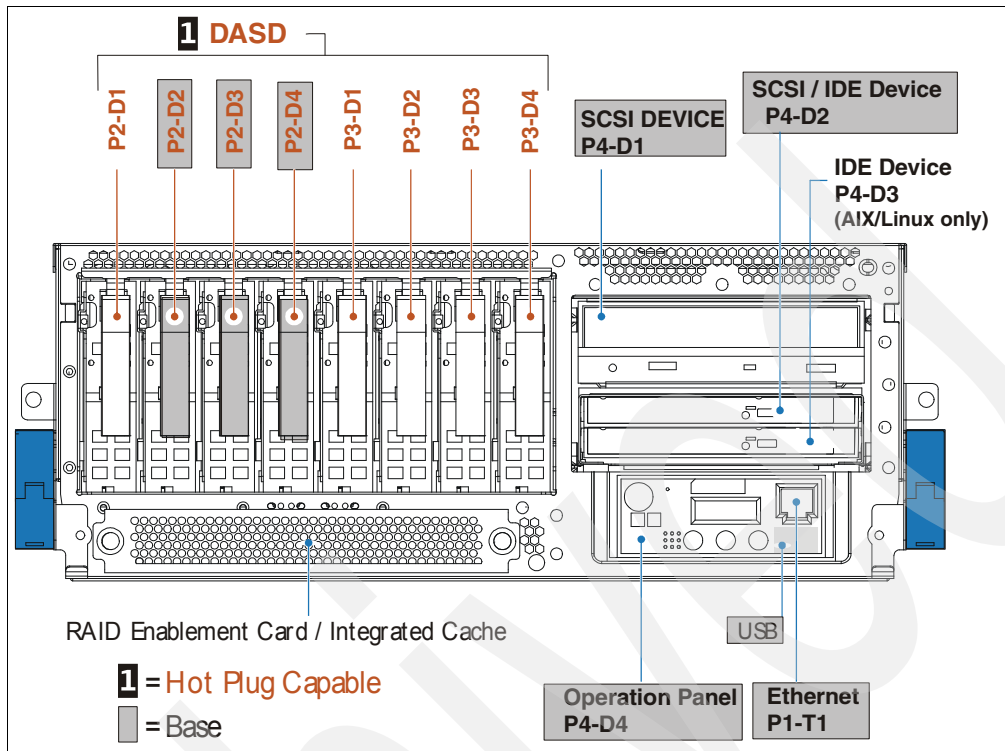

Model 520, 550,
570, 595

2.9.3 Models 550+ and 550 back view

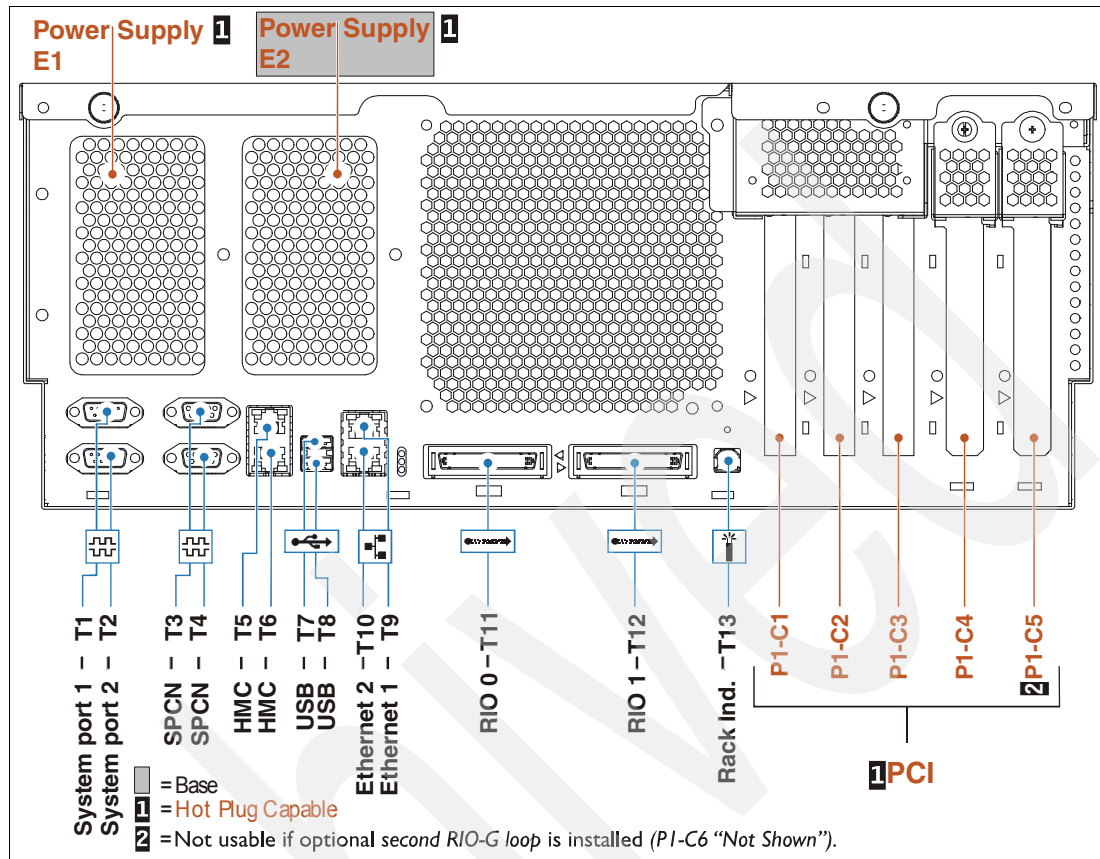

Note: An #1827 Serial-UPS Conversion Cable connects to system port 2. T9 is the default port 0 for the embedded LAN console.

2.9.4 Models 550+ and 550 memory layout

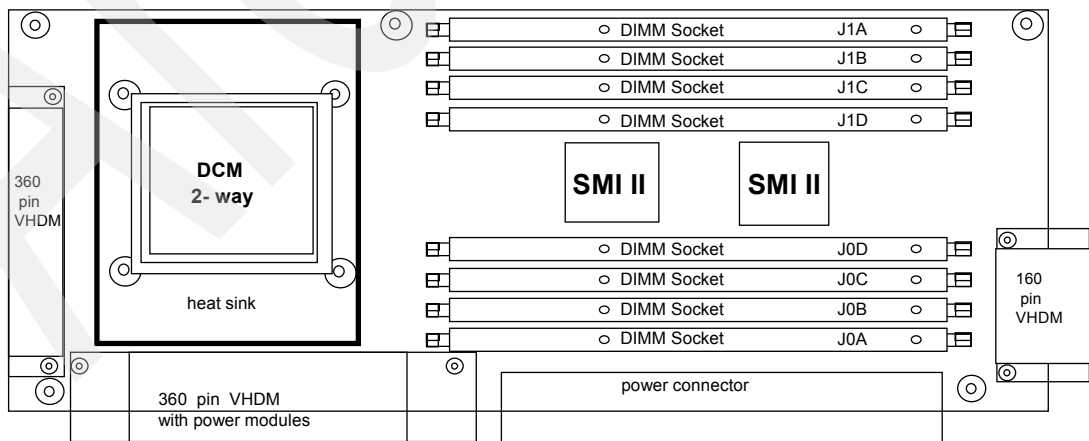

Note: There are two of these cards in every Model 550 and 550+.

2.10 9406 Models 570+ and 570 system unit schematics

2.10.1 Model 570+ top view

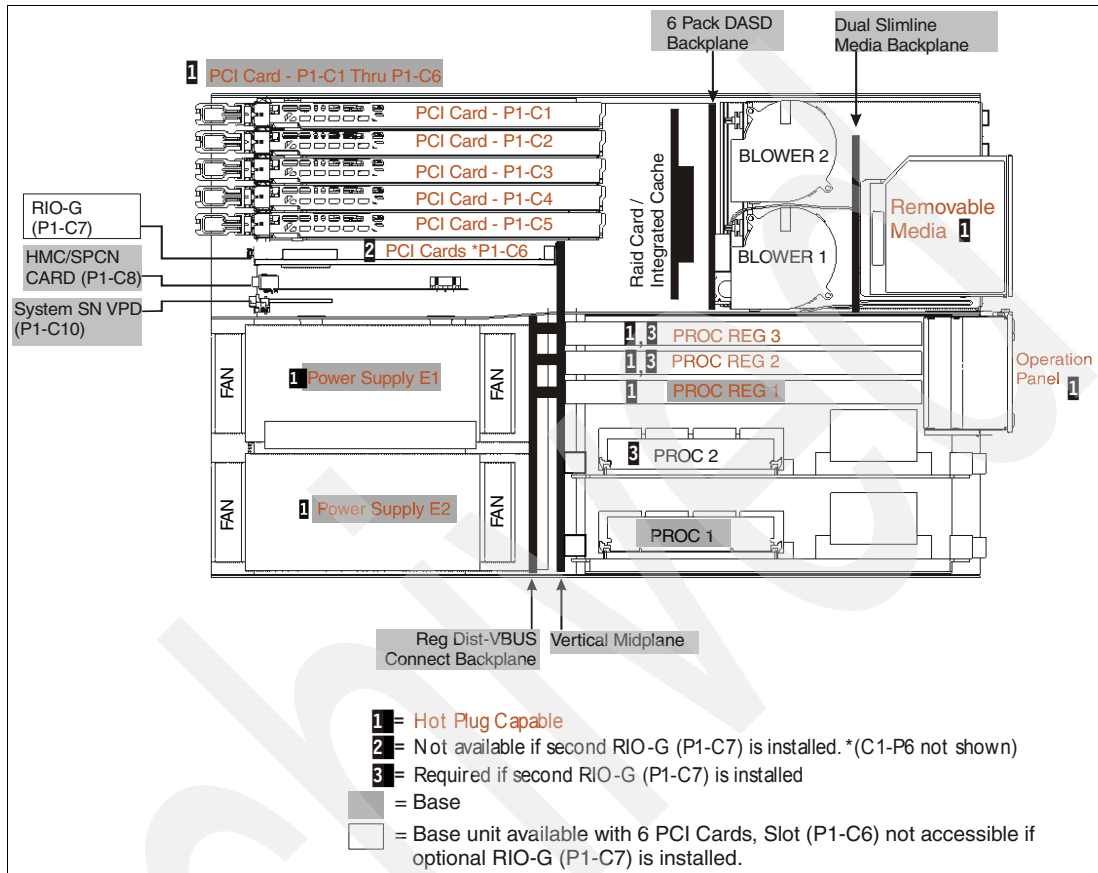

Model 520, 550,
570, 595

2.10.2 Models 570+ and 570 front view

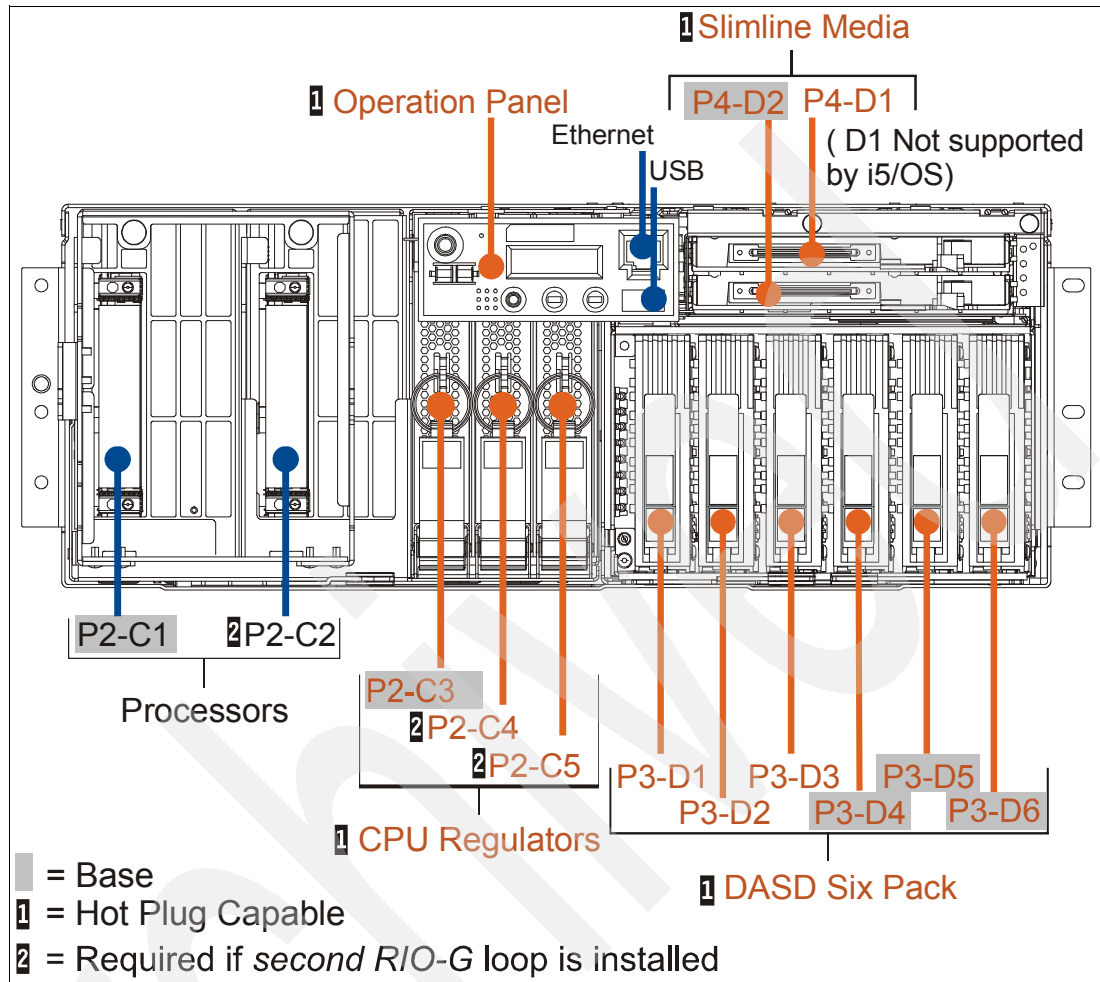

2.10.3 Models 570+ and 570 back view

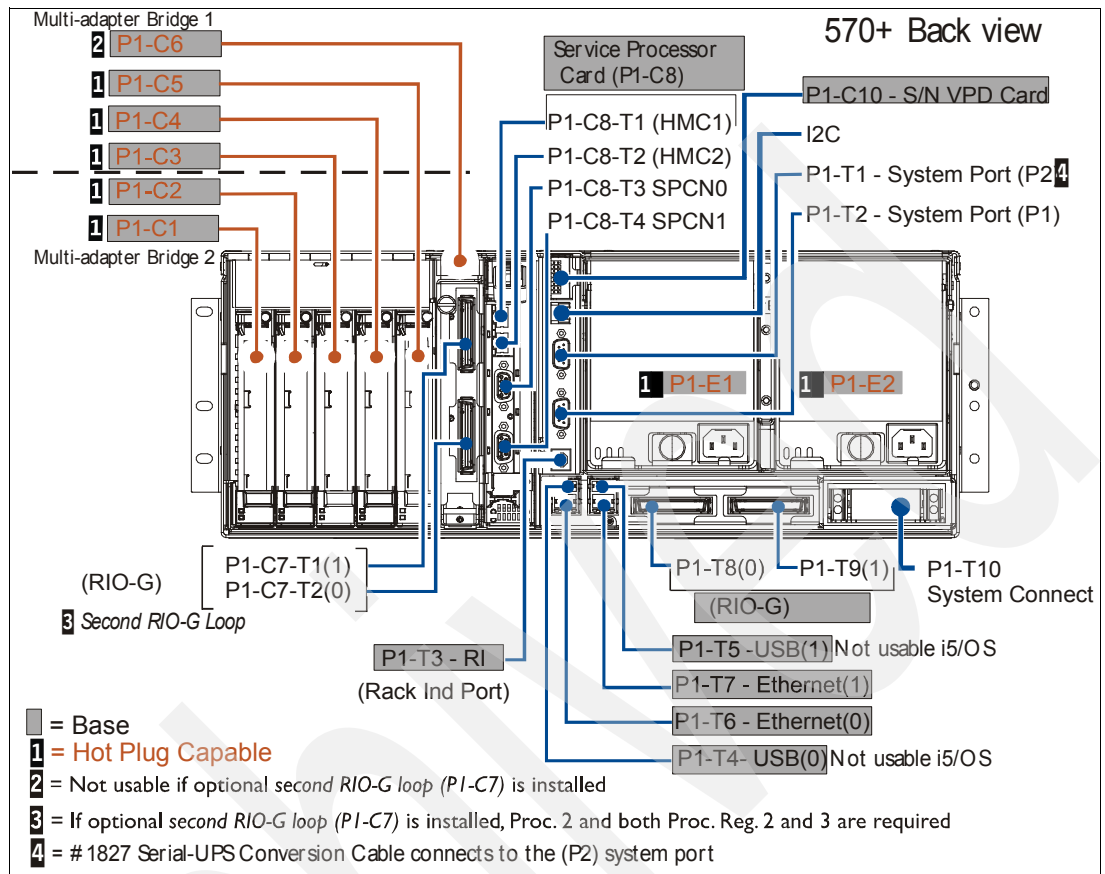

Note: An #1827 Serial-UPS Conversion Cable connects to system port 2. T6 is the default port 0 for the embedded LAN console.

Model 520, 550,
570, 595

2.10.4 Model 570 top view

Model 520, 550,
570, 595

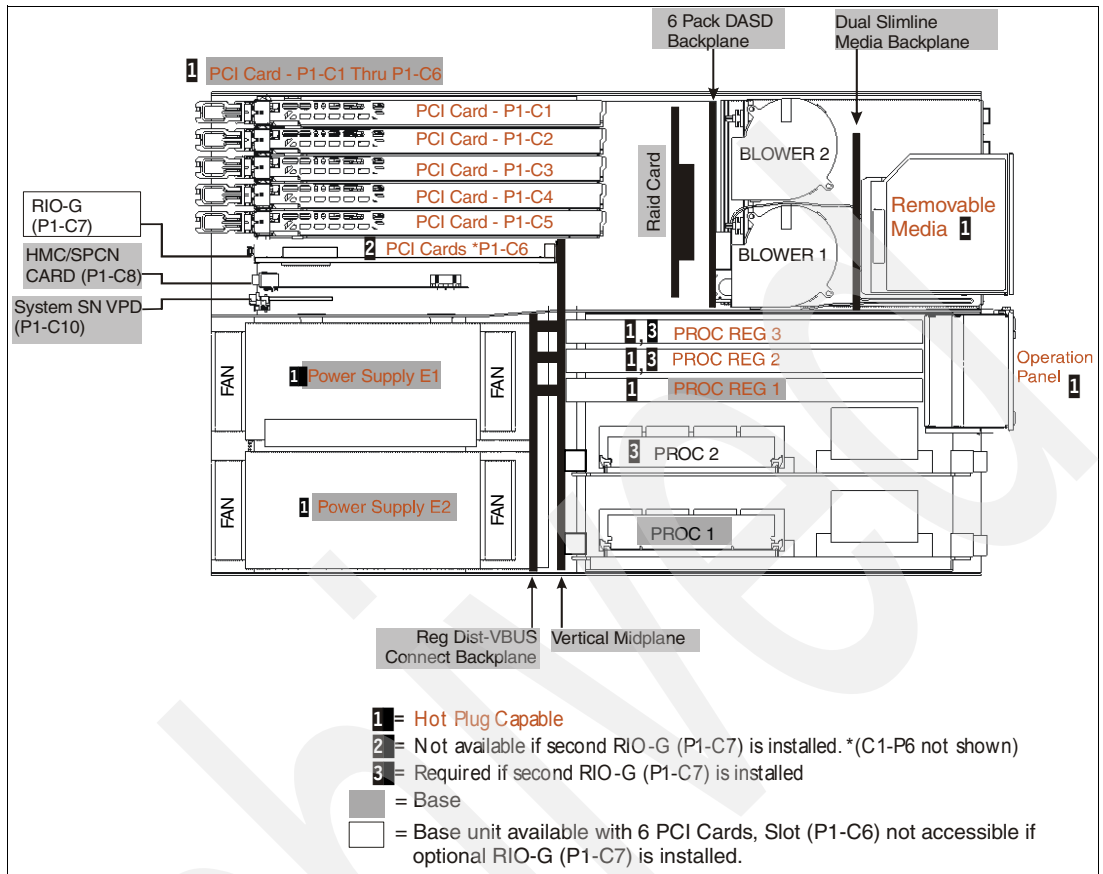

2.10.5 Model 570 front view

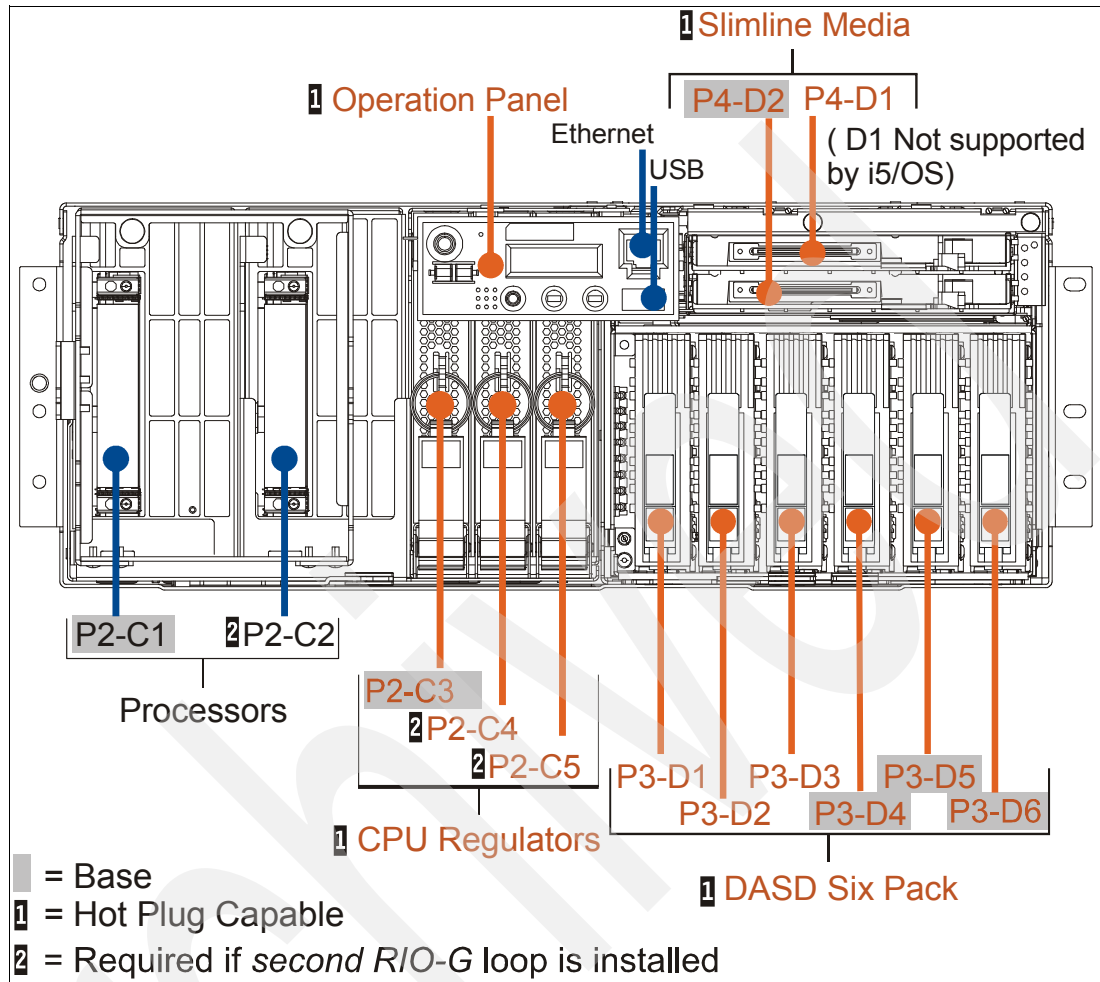

Model 520, 550,
570, 595

2.10.6 Models 570+ and 570 memory layout

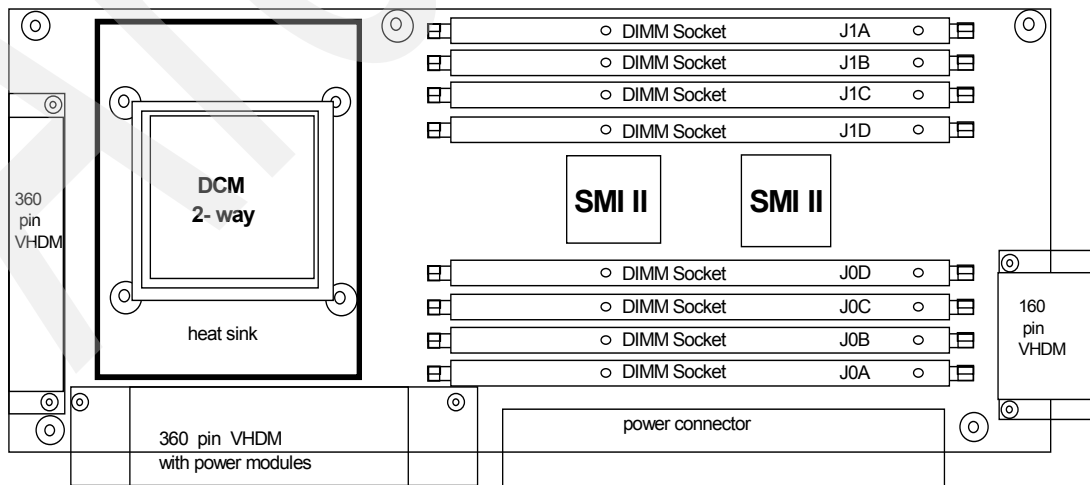

2.11 9406 Model 595 system unit schematics

2.11.1 Model 595 front view

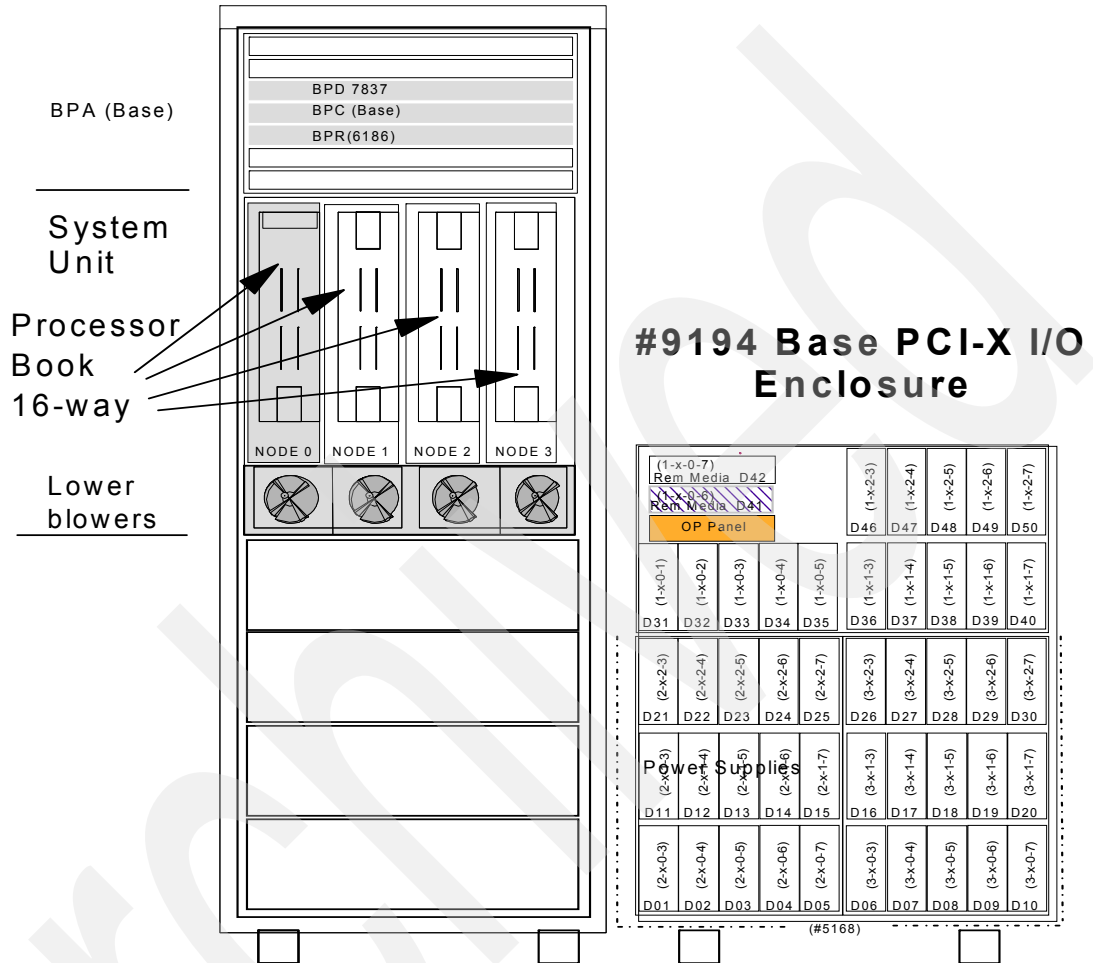

2.11.2 Model 595 back view

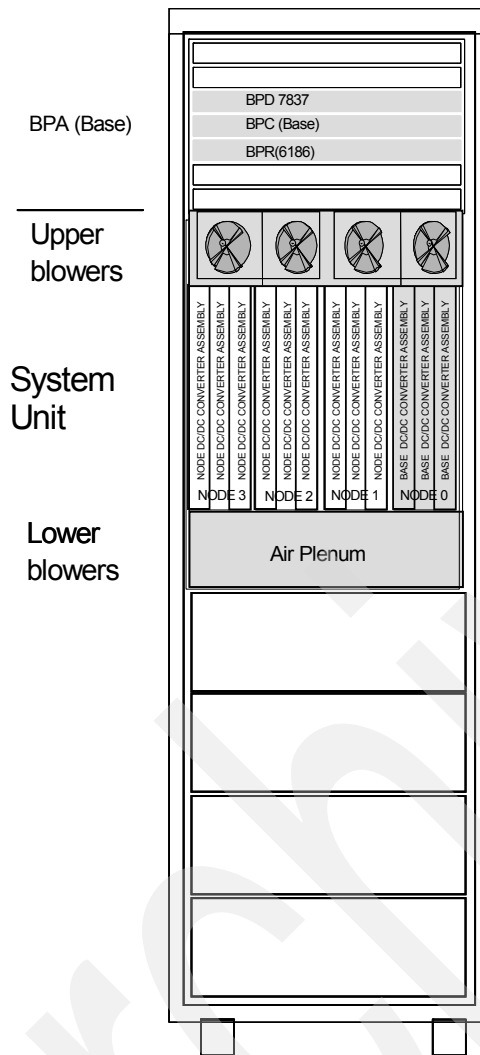

DASD plug sequence for optimum performance:
 D31, D36, D46, D32, D37, D47, ... D50, (add 2nd adaptor), D01, D11, D21, D02, ... D25, (add 3rd adaptor), D06, D16, D26, D07, ... D30.

#9194 Base PCI-X I/O enclosure

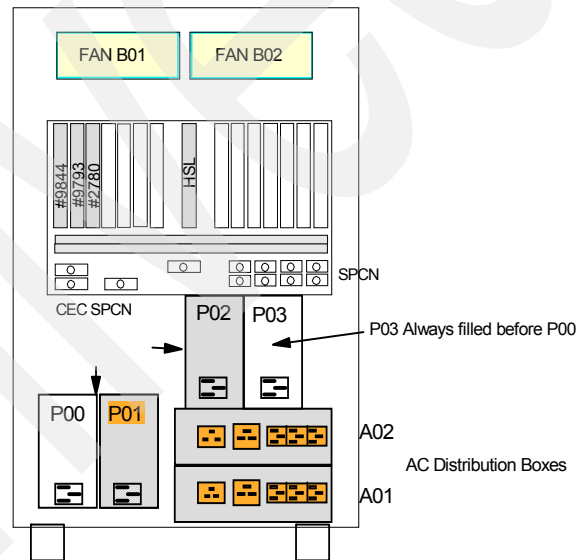

**Model 520, 550,
 570, 595**

2.11.3 Models 595+ and 595 memory layout

The following schematic illustrates the memory cards for a Model 595+ and 595 processor.

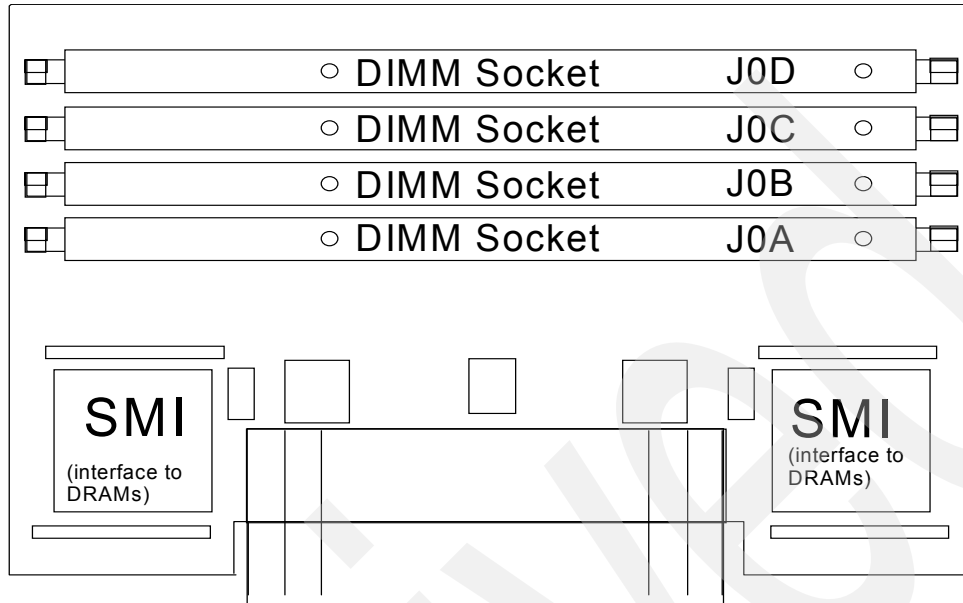

The following schematic illustrates a single processor book and memory node for two MultiChip Modules (MCMs) for Models 595+ and 595.

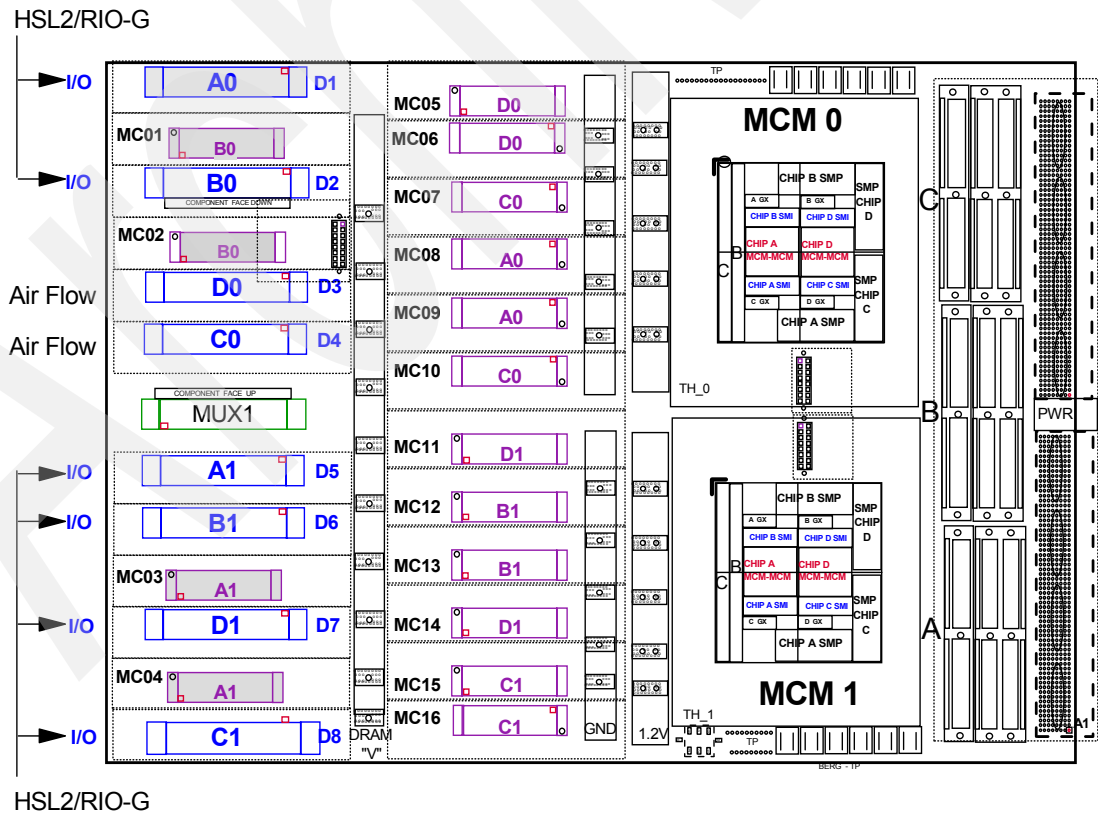

2.12 System i5 Model 520+ and eServer 520 processors

The IBM System i5 Model 520 and IBM eServer i5 Model 520 initial installation is Customer Setup (CSU). Processor upgrades within models are performed by IBM Service Representatives.

Model 520, 550,
570, 595

Processor feature	Server feature	Edition/ Config. feature	Model 520+ and 520 processors
#8325			#8325 600/3100 CPW Uni-Processor in Client/Server Environment <ul style="list-style-type: none"> ▶ POWER5+ 1.9 GHz Uni processor (CCIN 8325) ▶ Includes 8 DIMM memory positions (which plug directly onto the backplane - direct attach) ▶ No L3 cache ▶ Processor Capacity Card (CCIN 528F)
	#0970	#7140	#7140 520 Express Configuration Provides 600 CPW processor performance Provides 30 CPW for 5250 OLTP (CCIN 7140) Requires #7680 Accelerator for System i5 to achieve 3100 processor CPW Machine type 9405
		#7141	#7141 520 Express Configuration Provides 600 CPW processor performance Provides 30 CPW for 5250 OLTP (CCIN 7141) Requires #7681 Accelerator for System i5 to achieve 3100 processor CPW Machine type 9405
		#7142	#7142 520 Express Configuration Provides 600 CPW processor performance Provides 30 CPW for 5250 OLTP (CCIN 7142) Requires #7682 Accelerator for System i5 to achieve 3100 processor CPW Machine type 9405
		#0975	#7350
#8327			#8327 1200/2800/3800 CPW Uni-Processor in Client/Server Environment <ul style="list-style-type: none"> ▶ POWER5+ 1.9 GHz Uni processor (CCIN 8327) ▶ Includes 8 DIMM memory positions (which plug directly onto the backplane - direct attach) ▶ 36Mb L3 cache ▶ Processor Capacity Card (CCIN 528F)
	#0970	#7143	#7143 520 Express Configuration Provides 1200 CPW processor performance Provides 60 CPW for 5250 OLTP (CCIN 7143) Requires #7354 Accelerator for System i5 to achieve 3800 processor CPW Machine type 9405
		#7148	#7148 520 Express Configuration Provides 1200 CPW processor performance Provides 60 CPW for 5250 OLTP (CCIN 7148) Requires #7687 Accelerator for System i5 to achieve 3800 processor CPW Machine type 9405
		#7144	#7144 520 Express Configuration Provides 3800 CPW processor performance Provides 60 CPW for 5250 OLTP (CCIN 7144) Machine type 9405
		#7152	#7152 520 Express Configuration Provides 3800 CPW processor performance Provides 60 CPW for 5250 OLTP (CCIN 7350) Machine type 9405
	#0975	#7352	#7352 Value Edition for #0975 Provides 1200 CPW processor performance Provides 60 CPW for 5250 OLTP (CCIN 7352) Requires #7357 Accelerator for System i5 to achieve 3800 processor CPW Machine type 9406

Processor feature	Server feature	Edition/ Config. feature	Model 520+ and 520 processors
#8327	#0906	#7366	#7366 Solution Edition for #0906 Provides 1200 CPW processor performance Provides 1200 CPW for 5250 OLTP (CCIN 7366) Machine type 9406
		#7373	#7373 High Availability Edition for #0906 Provides 1200 CPW processor performance Provides 1200 CPW for 5250 OLTP (CCIN 7373) Machine type 9406
		#7374	#7374 High Availability Edition for #0906 Provides 2800 CPW processor performance Provides 2800 CPW for 5250 OLTP (CCIN 7374) Machine type 9406
		#7734	#7734 Enterprise Edition for #0906 Provides 1200 CPW processor performance Provides 1200 CPW for 5250 OLTP (CCIN 7734) Machine type 9406
		#7735	#7735 Enterprise Edition for #0906 Provides 2800 CPW processor performance Provides 2800 CPW for 5250 OLTP (CCIN 7735) Machine type 9406
		#7784	#7784 Standard Edition for #0906 Provides 3800 CPW processor performance Provides 0 CPW for 5250 OLTP (CCIN 7748) Machine type 9406
#8330			#8330 3800/7100 CPW 0/2-way Processor in Client/Server Environment <ul style="list-style-type: none"> ▶ POWER5+ 1.9 GHz 0/2-way processor (CCIN 8330) ▶ Includes 8 DIMM memory positions (which plug directly onto the backplane - direct attach) ▶ 36Mb L3 cache ▶ Processor Capacity Card (CCIN 528F)
	#0906	#7375	#7375 High Availability Edition for #0906 Provides 3800/7100 CPW processor performance Provides 3800/7100 CPW for 5250 OLTP (CCIN 7375) Machine type 9406
		#7736	#7736 Enterprise Edition for #0906 Provides 3800/7100 CPW processor performance Provides 3800/7100 CPW for 5250 OLTP (CCIN 7736) Machine type 9406
		#7785	#7785 Standard Edition for #0906 Provides 3800/7100 CPW processor performance Provides 0 CPW for 5250 OLTP (CCIN 7785) Machine type 9406

Processor feature	Server feature	Edition/ Config. feature	Model 520+ and 520 processors
#8950	#0900		#8950 500 CPW Uni-Processor in Client/Server Environment <ul style="list-style-type: none"> ▶ POWER5 1.5 GHz Uni (CCIN 522A) ▶ Includes 8 DIMM memory positions (which plug directly onto the backplane - direct attach) ▶ No L3 cache ▶ #7450 Processor Capacity Card (CCIN 7450)
		#7390	#7390 Express Edition Provides 30 CPW for 5250 OLTP (CCIN 7390) Machine type 9406
		#7391	#7391 Express Edition Provides 30 CPW for 5250 OLTP (CCIN 7391) Machine type 9406
		#7393	#7393 Express Edition Provides 30 CPW for 5250 OLTP (CCIN 7393) Machine type 9406
		#7411	#7411 Express Edition Provides 30 CPW for 5250 OLTP (CCIN 7411) Machine type 9406 The #7411 Express Edition is withdrawn from marketing as of 01 April 2005.
		#7413	#7413 Express Edition Provides 30 CPW for 5250 OLTP (CCIN 7413) Machine type 9406 The #7413 Express Edition is withdrawn from marketing as of 01 April 2005.
		#7417	#7417 Express Edition Provides 30 CPW for 5250 OLTP (CCIN 7417) Machine type 9406 The #7417 Express Edition is withdrawn from marketing as of 01 April 2005.
		#7450	#7450 Value Edition Provides 30 CPW for 5250 OLTP (CCIN 7450)
#8951	#0901		#8951 1000 CPW Uni-Processor in Client/Server Environment <ul style="list-style-type: none"> ▶ POWER5 1.5 GHz Uni (CCIN 522A) ▶ Includes 8 DIMM memory positions (which plug directly onto the backplane - direct attach) ▶ No L3 cache ▶ #7451 Processor Capacity Card (CCIN 7451)
		#7392	#7392 Express Edition Provides 60 CPW for 5250 OLTP (CCIN 7392) Machine type 9405.
		#7394	#7394 Express Edition Provides 60 CPW for 5250 OLTP (CCIN 7394) Machine type 9405.
		#7414	#7414 Express Edition Provides 60 CPW for 5250 OLTP (CCIN 7414) Machine type 9406. The #7414 Express Edition is withdrawn from marketing for new orders only on 01 April 2005. Conversions to feature remain available.
		#7417	#7417 Express Edition Provides 60 CPW for 5250 OLTP (CCIN 7417) Machine type 9406. The #7417 Express Edition is withdrawn from marketing as of 01 April 2005.
		#7420	#7420 Express Edition Provides 60 CPW for 5250 OLTP (CCIN 7451) Machine type 9406. The #7420 Express Edition is withdrawn from marketing as of 01 April 2005.
		#7451	#7451 Value Edition Provides 60 CPW for 5250 OLTP (CCIN 7451)

Processor feature	Server feature	Edition/ Config. feature	Model 520+ and 520 processors
#8952	#0902		#8952 1000 CPW Uni-Processor in Client/Server Environment <ul style="list-style-type: none"> ▶ POWER5 1.5 GHz Uni (CCIN 522A) ▶ Includes 8 DIMM memory positions (which plug directly onto the backplane - direct attach) ▶ No L3 cache ▶ #7458/#7459 Processor Capacity Card (CCIN 7458/7459)
		#7458	#7458 Standard Edition Provides limited 5250 OLTP (CCIN 7458)
		#7459	#7459 Enterprise Edition Provides up to 1000 CPW for 5250 OLTP (CCIN 7459)
		#7541	#7541 Solution Edition Provides up to 1000 CPW for 5250 OLTP (CCIN 7451)
		#7552	#7552 High Availability Edition Provides up to 1000 CPW for 5250 OLTP (CCIN 7459)
#8953	#0903		#8953 2400 CPW Uni-Processor in Client/Server Environment <ul style="list-style-type: none"> ▶ POWER5 1.5 GHz Uni (CCIN 522A) ▶ Includes 8 DIMM memory positions (which plug directly onto the backplane - direct attach) ▶ No L3 cache ▶ #7452/#7453 Processor Capacity Card (CCIN 7452/7453)
		#7452	#7452 Standard Edition Provides limited 5250 OLTP (CCIN 7452)
		#7453	#7453 Enterprise Edition Provides up to 2300 CPW for 5250 OLTP (CCIN 7453)
		#7553	#7553 High Availability Edition Provides up to 2300 CPW for 5250 OLTP (CCIN 7453)
#8954	#0904		#8954 3300 CPW Uni-Processor in Client/Server Environment <ul style="list-style-type: none"> ▶ POWER5 1.65 GHz Uni (CCIN 5228) ▶ Includes 8 DIMM memory positions (which plug directly onto the backplane - direct attach) ▶ 36 MB L3 cache ▶ #7454/#7455 Processor Capacity Card (CCIN 7454/7455)
		#7454	#7454 Standard Edition Provides limited 5250 OLTP (CCIN 7454)
		#7455	#7455 Enterprise Edition Provides up to 3300 CPW for 5250 OLTP (CCIN 7455)
		#7554	#7554 High Availability Edition Provides up to 3300 CPW for 5250 OLTP (CCIN 7455)
#8955	#0905		#8955 6000 CPW 2-way Processor in Client/Server Environment <ul style="list-style-type: none"> ▶ POWER5 1.65 GHz 2-way (CCIN 5229) ▶ Includes 8 DIMM memory positions (which plug directly onto the backplane - direct attach) ▶ 36 MB L3 cache ▶ #7456/#7457 Processor Capacity Card (CCIN 7454/7455)
		#7456	#7456 Standard Edition Provides limited 5250 OLTP (CCIN 7456)
		#7457	#7457 Enterprise Edition Provides up to 6000 CPW for 5250 OLTP (CCIN 7457)
		#7555	#7555 High Availability Edition Provides up to 6000 CPW for 5250 OLTP (CCIN 7457)
#8972	#0912	#7395	#7395 Express Edition Provides up to 60 CPW for OLTP (CCIN 7395)
		#7396	#7396 Express Edition Provides up to 60 CPW for OLTP (CCIN 7395)
		#7397	#7397 Value Edition Provides up to 60 CPW for OLTP (CCIN 7395)
Models 520+ and 520 CUoD and OLTP features			
#7256	#7256 520 Enterprise Enablement The #7256 is ordered when additional 5250 OLTP capability is required on a permanently activated processor on a Model 520 Enterprise Edition system. An additional i5/OS license might be required. Supported on Model 520+. Minimum operating system level: i5/OS V5R3 Minimum LIC level: V5R3M5		

Processor feature	Server feature	Edition/ Config. feature	Model 520+ and 520 processors
#7320			<p>#7320 520 One Processor Activation</p> <p>The #7320 provides an activation code that can be used to permanently activate one additional processor on a Model 520 CUoD system with #0906 Server Feature and #8330 Processor Feature.</p> <p>Supported on Model 520+.</p> <p>Minimum operating system level: i5/OS V5R3</p> <p>Minimum LIC level: V5R3M5</p>
#7575			<p>#7575 520 Enterprise Enablement</p> <p>The #7575 is ordered when additional 5250 OLTP capability is required on a permanently activated processor on a Model 520 Enterprise Edition server. An additional i5/OS license might be required.</p> <p>Supported on Model 520.</p> <p>Minimum operating system level: i5/OS V5R3</p>
#7620			<p>#7620 520 On/Off Processor Enablement</p> <p>The #7620 is ordered to enable On/Off Capacity on Demand. Once enabled, processors can be requested on a temporary basis. An On/Off Capacity on Demand contract must be signed before ordering this feature.</p> <p>Supported on Model 520+.</p> <p>Minimum operating system level: i5/OS V5R3</p> <p>Minimum LIC level: V5R3M5</p>
#7621			<p>#7621 520 On/Off Processor Day Billing</p> <p>Order one #7621 for each billable processor day.</p> <p>Supported on Model 520+.</p> <p>Minimum operating system level: i5/OS V5R3</p> <p>Minimum LIC level: V5R3M5</p>
#7622			<p>#7622 520 Reserve Capacity Prepaid</p> <p>The #7622 provides 30 processor-days of reserve capacity on a Capacity Upgrade on Demand system.</p> <p>Supported on Model 520+.</p> <p>Minimum operating system level: i5/OS V5R3</p> <p>Minimum LIC level: V5R3M5</p>
#8410			<p>#8410 520 Base Processor Activation</p> <p>The #8410 provides an activation code that can be used to permanently activate one processor on a Model 520 CUoD system with #0906 Server Feature and #8330 Processor Feature. An additional i5/OS license might be required.</p> <p>Supported on Model 520+.</p> <p>Minimum operating system level: i5/OS V5R3</p> <p>Minimum LIC level: V5R3M5</p>
#9286			<p>#9286 Base Enterprise Enablement</p> <p>The #9286 is placed on an order of an Enterprise Edition server to enable one processor's worth of 5250 OLTP capability. Multiple #9286s can be on the order.</p> <p>Supported on Models 520 (9406 only), 550, 570, and 595</p> <p>Minimum operating system level: i5/OS V5R3</p>
#9299			<p>#9299 Base Enterprise Enablement</p> <p>The #9299 is placed on an order of an Enterprise Edition system to enable one processor's worth of 5250 OLTP capability.</p> <p>Supported on Model 520+ (9406 only)</p> <p>Minimum operating system level: i5/OS V5R3</p> <p>Minimum LIC level: V5R3M5</p>

2.13 IBM System i5 and eServer i5 Model 550 processors

The Models 550+ and 550 initial installation is IBM installed. Processor upgrades within models are performed by IBM Service Representatives.

Processor feature	Server feature	Edition feature	Models 550+ and 550 processor
#8312	#0910		#8312 3800/14000 CPW 1/4-way Processor in Client/Server Environment <ul style="list-style-type: none"> ▶ Includes two #8312 0/2-way POWER5+ 1.9 GHz processors ▶ Includes one #8413 550 Base Processor Activation ▶ Includes eight main storage DIMM positions per processor card ▶ 36MB L3 cache
		#7154	#7154 Standard Edition for #0910 Provides limited 5250 OLTP (CCIN 7154)
		#7155	#7155 Enterprise Edition for #0910 Provides up to 3800/14000 CPW for 5250 OLTP (CCIN 7155)
		#7551	#7551 High Availability Edition for #0910 Provides up to 3800/14000 CPW for 5250 OLTP. Processor Capacity Card (CCIN 7551)
		#7629	#7629 Domino Edition for #0910 Provides limited 5250 OLTP. Processor Capacity Card (CCIN 7629)
		#7630	#7630 Solution Edition for #0910 Provides up to 3800/14000 CPW for 5250 OLTP. Processor Capacity Card (CCIN 7630)
		#7631	#7631 Solution Edition PeopleSoft EnterpriseOne Provides up to 3800/14000 CPW for 5250 OLTP. Processor Capacity Card (CCIN 7631)
		#7632	#7632 C2CRM Solution Edition with Domino Provides up to 3800/14000 CPW for 5250 OLTP. Processor Capacity Card (CCIN 7632)
		#7640	#7640 2-way SAP Solution Edition Provides limited 5250 OLTP. Processor Capacity Card (CCIN 7640)
		#7641	#7641 4-way SAP Solution Edition Provides limited 5250 OLTP. Processor Capacity Card (CCIN 7641)
#8958	#0915		#8958 3300/12000 CPW 1/4-way Processor in Client/Server Environment <ul style="list-style-type: none"> ▶ Includes two #8958 0/2-way POWER5 1.65 GHz processors ▶ Includes one #8450 550 Base Processor Activation ▶ Includes eight main storage DIMM positions per processor card ▶ 36MB L3 cache
		#7462	#7462 Standard Edition Provides limited 5250 OLTP (CCIN 7462)
		#7463	#7463 Enterprise Edition Provides up to 3300/12000 CPW for 5250 OLTP (CCIN 7463)
		#7530	#7530 Domino Edition Processor Capacity Card (CCIN 7530)
		#7531	#7531 Solution Edition for PeopleSoft EnterpriseOne Processor Capacity Card (CCIN 7531)
		#7532	#7532 C2CRM Solution Edition with Domino Processor Capacity Card (CCIN 7532)
		#7533	#7533 2-Way SAP Solution Edition Processor Capacity Card (CCIN 7533)
		#7534	#7534 4-Way SAP Solution Edition Processor Capacity Card (CCIN 7534)
		#7558	#7558 Solution Edition Processor Capacity Card (CCIN 7558)

Models 550+ and 550 CUoD and OLTP features	
#7257	<p>#7257 550 Enterprise Enablement The #7257 is ordered when additional 5250 OLTP capability is required on a Model 550 Enterprise Edition, High Availability Edition or Solution Edition servers. One additional processor's worth of 5250 OLTP capacity is authorized with each feature. This 5250 capacity can be used across multiple physical #8312 processors which have been permanently activated. An additional i5/OS license might be required. Supported on #8312 processor only. Minimum operating system level: i5/OS V5R3</p>
#7323	<p>#7323 550 One Processor Activation Ordering this feature results in an activation code that can be used to permanently activate one additional processor on a Model 550. One or more activation features can be ordered. Supported on #8312 processor only. Minimum operating system level: i5/OS V5R3</p>
#7341	<p>#7341 550 On/Off Processor Day Billing After the #7930 On/Off Processor Enablement feature is ordered and the associated enablement code is entered into the system, on/off usage must be reported to IBM at least monthly. This information is used to compute the billing data which is then given to the local sales channel. The sales channel places an order for a quantity of #7341 On/Off Processor Day Billing features and its associated charges. One #7341 is ordered for each billable processor day. #7930 550 On/Off Processor Enablement is required. Supported on #8312 processor only. Minimum operating system level: i5/OS V5R3</p>
#7576	<p>#7576 550 Enterprise Enablement The #7576 is ordered when additional 5250 OLTP capability is required on a permanently activated processor on a Model 550 #8958 Enterprise Edition server. An additional i5/OS license might be required. Supported on #8958 processor only. Minimum operating system level: i5/OS V5R3</p>
#7741	<p>#7741 550 Reserve Capacity Prepaid The #7741 provides 30 processor-days of reserve capacity on a Model 550 #8312 processor. Capacity Upgrade on Demand (CUoD) server. Reserve capacity is established on a server by selecting a quantity of inactive processors to be placed in the server's Shared Processor Pool as reserve processors. When the server recognizes that non-reserve processors (permanently activated processors) assigned and/or available to the uncapped partitions are 100% utilized, a processor day (valid for a 24-hour period) is subtracted from the prepaid amount of days. Supported on #8312 processor only. Minimum operating system level: i5/OS V5R3</p>
#7871	<p>#7871 550 CUoD Processor Activation The #7871 feature results in an activation code that can be used to permanently activate one additional processor on an eServer i5 550 server. One or more activation features can be ordered. Supported on #8958 processor only. Minimum operating system level: i5/OS V5R3</p>
#7930	<p>#7930 550 On/Off Processor Enablement The #7930 is ordered to enable a 550 server for On/Off Capacity on Demand. When enabled, processors can be requested on a temporary basis. On/Off Capacity on Demand contracts must be signed before this feature is ordered. Prior to reaching the limit of enabled temporary processor days, this feature can be reordered. Supported on #8312 and the #8958 processors. Minimum operating system level: i5/OS V5R3</p>
#7931	<p>#7931 550 On/Off Processor Day Billing After the #7930 On/Off Processor Enablement feature is ordered and the associated enablement code is entered into the system, on/off usage must be reported to IBM at least monthly. This information is used to compute the billing data, which is then given to the local sales channel. The sales channel places an order for a quantity of the #7931 On/Off Processor Day Billing features and its associated charges. Order one #7931 for each billable processor day. The #7958 is supported on the #8958 processor only. Minimum operating system level: i5/OS V5R3</p>
#7934	<p>#7934 550 Reserve Capacity Prepaid The #7934 provides 30 processor days of reserve capacity on a Model 550 Capacity Upgrade on Demand (CUoD) server. To establish reserve capacity on the server, select a quantity of inactive processors to be placed in the server's shared processor pool as reserve processors. When the server recognizes that non-reserve processors (permanently activated processors) assigned or available to the uncapped partitions have been 100% utilized, a processor day (good for a 24-hour period) is subtracted from the prepaid amount of days. Supported on #8958 processor only. Minimum operating system level: i5/OS V5R3</p>

#8413	#8413 550 Base Processor Activation The #8413 feature provides an activation code that can be used to permanently activate one additional processor on a Model 550 server. One or more of these no-charge activation features can be ordered, depending on the configuration rules. The #7741 is supported on the #8312 processor only. Minimum operating system level: i5/OS V5R3
#8450	#8450 550 Base Processor Activation The #8450 feature provides an activation code that can help permanently activate one additional processor on an eServer i5 #8958 550 server. One or more of these no-charge activation features can be ordered, depending on configuration rules. The #8450 is supported on the #8958 processor only Minimum operating system level: i5/OS V5R3
#9286	#9286 Base Enterprise Enablement The #9286 is placed on an order of an Enterprise Edition server to enable one processor's worth of 5250 OLTP capability. Multiple #9286s can be on the order. Supported on Models 520 (9406 only), 550, 570, and 595 Minimum operating system level: i5/OS V5R3
#9299	#9299 Base Enterprise Enablement The #9299 is placed on an order of an Enterprise Edition server to enable one processor's worth of 5250 OLTP capability. Multiple #9299's can be on the order. Supported on #8312 processor only. Minimum operating system level: i5/OS V5R3

2.14 IBM System i5 and eServer i5 Model 570 processors

The Models 570+ and 570 initial installation is IBM installed. Processor upgrades within models are performed by IBM Service Representatives.

Processor	Processor activation feature	Server feature	Edition feature	Model 570+ processor
#8338	#7618	#0934		#8338 8400/16000 CPW 2/4-way Processor in Client/Server Environment <ul style="list-style-type: none"> ▶ Includes two #8338 0/2-way POWER5+ 2.2 GHz processor (CCIN 8338) ▶ Includes two #7738 Base Processor Activation features ▶ Includes 36 MB L3 cache per processor card ▶ Includes eight main memory DIMM slots per processor card
			#7757	#7757 Standard Edition Provides limited 5250 OLTP CPW (CCIN 7757)
			#7747	#7747 Enterprise Edition Provides up to 16000 CPW for 5250 OLTP CPW (CCIN 7747)
			#7763	#7763 High Availability Edition Provides up to 16000 CPW for 5250 OLTP CPW (CCIN 7763)
#8338	#7618	#0935		#8338 16700/31100 CPW 4/8-way Processor in Client/Server Environment <ul style="list-style-type: none"> ▶ Includes four #8338 0/2-way POWER5+ 2.2 GHz processors (CCIN 8338) ▶ Includes four #7738 Base Processor Activation features ▶ Includes 36 MB L3 cache per processor card ▶ Includes eight main memory DIMM slots per processor card
			#7758	#7758 Standard Edition Provides limited 5250 OLTP CPW (CCIN 7758)
			#7748	#7748 Enterprise Edition Provides up to 311000 CPW for 5250 OLTP CPW (CCIN 7748)
			#7764	#7764 High Availability Edition Provides up to 311000 CPW for 5250 OLTP CPW (CCIN 7764)

Processor	Processor activation feature	Server feature	Edition feature	Model 570+ processor
#8338	#7618	#0936		#8338 31100/58500 CPW 8/16way Processor in Client/Server Environment <ul style="list-style-type: none"> ▶ Includes eight #8338 0/2-way POWER5+ 2.2 GHz processor (CCIN 8338) ▶ Includes eight #7738 Base Processor Activation features ▶ Includes 36 MB L3 cache per processor card ▶ Includes eight main memory DIMM slots per processor card
			#7759	#7759 Standard Edition Provides limited 5250 OLTP CPW (CCIN 7759)
			#7749	#7749 Enterprise Edition Provides up to 58500 CPW for 5250 OLTP CPW (CCIN 7749)
			#7765	#7765 High Availability Edition Provides up to 58500 CPW for 5250 OLTP CPW (CCIN 7765)
#8338	#7618	#0937		#8338 18100/58500 CPW 2/16-way Processor in Client/Server Environment <ul style="list-style-type: none"> ▶ Includes eight #8338 0/2way POWER5+ 2.2 GHz processor (CCIN 8338) ▶ Includes two #7738 Base Processor Activation features ▶ Includes 36 MB L3 cache per processor card ▶ Includes eight main memory DIMM slots per processor card
			#7760	#7760 Capacity BackUp Edition Provides limited 5250 OLTP CPW (CCIN 7760)

Processor	Processor activation feature	Server feature	Edition feature	Model 570+ processor
#8961	#7897	#0919		#8961 3300/6000 CPW 0/2-way Processor in Client/Server Environment <ul style="list-style-type: none"> ▶ Includes one #8961 0/2-way POWER5 1.65 GHz processor (CCIN 26EA) ▶ Includes one #8452 Base Processor Activation feature ▶ Includes 36 MB L3 cache per processor card ▶ Includes eight main memory DIMM slots per processor card The #8961 0/2-way processor is withdrawn from marketing as of 01 October 2004.
			#7488	#7488 Standard Edition Provides limited 5250 OLTP CPW (CCIN 7488) The #7488 Standard Edition is withdrawn from marketing as of 01 October 2004.
			#7489	#7489 Enterprise Edition Provides up to 6000 CPW for 5250 OLTP CPW (CCIN 7489) The #7489 Enterprise Edition is withdrawn from marketing as of 01 October 2004.
#8961	#7897	#0920		#8961 6350/11700 CPW 2/4-way Processor in Client/Server Environment <ul style="list-style-type: none"> ▶ Includes two #8961 0/2-way POWER5 1.65 GHz processors (CCIN 26F2) ▶ Includes two #8452 Base Processor Activation features ▶ Includes 36 MB L3 cache per processor card ▶ Includes eight main memory DIMM slots per processor card The #8961 2/4-way processor is withdrawn from marketing as of 01 October 2004.
			#7469	#7469 Standard Edition Provides limited 5250 OLTP CPW (CCIN 7469)
			#7470	#7470 Enterprise Edition Provides up to 12000 CPW for 5250 OLTP CPW (CCIN 7470) The #7470 Enterprise Edition for the #8961 Processor feature is withdrawn from marketing as of 01 October 2004. The #7495 Standard Edition for #0921 is the recommended replacement.

Processor	Processor activation feature	Server feature	Edition feature	Model 570+ processor
#8971	#7897	#0921		#8971 6350/12000 CPW 2/4way Processor in Client/Server Environment <ul style="list-style-type: none"> ▶ Includes one #8971 0/2-way POWER5 1.65 GHz processor (CCIN 26F2) ▶ Includes two #8452 Base Processor Activation feature ▶ Includes 36 MB L3 cache per processor card ▶ Includes eight main memory DIMM slots per processor card
			#7494	#7494 Standard Edition Provides limited 5250 OLTP CPW (CCIN 7494)
			#7495	#7495 Enterprise Edition Provides up to 11200 CPW for 5250 OLTP CPW (CCIN 7470)
			#7560	#7560 High Availability Edition Processor Capacity Card (CCIN 7495)
#8971	#7897	#0922		#8971 15200/23650 CPW 4/8-way Processor in Client/Server Environment <ul style="list-style-type: none"> ▶ Includes two #8971 0/2-way POWER5 1.65 GHz processor (CCIN 26F2) ▶ Includes five #8452 Base Processor Activation feature ▶ Includes 36 MB L3 cache per processor card ▶ Includes eight main memory DIMM slots per processor card
			#7471	#7471 Standard Edition Provides limited 5250 OLTP CPW (CCIN 7494)
			#7472	#7472 Enterprise Edition Provides up to 23650 CPW for 5250 OLTP CPW (CCIN 7470)
			#7561	#7561 High Availability Edition Processor Capacity Card (CCIN 7472)
#8971	#7897	#0924		#8971 25500/33400 CPW 9/12 Processor in Client/Server Environment <ul style="list-style-type: none"> ▶ Includes four #8971 0/2-way POWER5 1.65 GHz processor (CCIN 26F2) ▶ Includes nine #8452 Base Processor Activation feature ▶ Includes 36 MB L3 cache per processor card ▶ Includes eight main memory DIMM slots per processor card
			#7473	#7473 Standard Edition Provides limited 5250 OLTP CPW (CCIN 7494)
			#7474	#7474 Enterprise Edition 33400 CPW for 5250 OLTP CPW (CCIN 7474)
			#7562	#7562 High Availability Edition Processor Capacity Card (CCIN 7474)
#8971	#7897	#0926		#8971 36300/44700 CPW 13/16 Processor in Client/Server Environment <ul style="list-style-type: none"> ▶ Includes eight #8971 0/2-way POWER5 1.65 GHz processor (CCIN 26F2) ▶ Includes thirteen #8452 Base Processor Activation feature ▶ Includes 36 MB L3 cache per processor card ▶ Includes eight main memory DIMM slots per processor card
			#7475	#7475 Standard Edition Provides limited 5250 OLTP CPW (CCIN 7494)
			#7476	#7476 Enterprise Edition Provides up to 44700 CPW for 5250 OLTP CPW (CCIN 7476)
			#7563	#7563 High Availability Edition Processor Capacity Card (CCIN 7476)
#8971	#7897	#0928		#8971 6350/44700 CPW 13/16 Processor in Client/Server Environment <ul style="list-style-type: none"> ▶ Includes eight #8971 0/2-way POWER5 1.65 GHz processor (CCIN 26F2) ▶ Includes two 8452 Base Processor Activation feature ▶ Includes 36 MB L3 cache per processor card ▶ Includes eight main memory DIMM slots per processor card
			#7570	#7570 Capacity BackUp Edition Provides up to 37400 CPW for 5250 OLTP for the Capacity BackUp Edition (CCIN 7570)
#8971	#7897	#0930	#7559	#7559 High Availability Edition Provides up to 37400 CPW for 5250 OLTP for the High Availability Edition (CCIN 7559)

Model 570+ and 570 CUoD and OLTP features	
#7258	<p>#7258 570 Full Enterprise Enablement</p> <p>The #7258 - 570 Full Enterprise Enable is ordered when complete 5250 OLTP capability is required for all permanently activated processors on 2/4-way, 4/8-way and 8/16-way model 570 Enterprise Edition or High Availability Edition systems. An additional i5/OS license might be required.</p> <p>Supported on Model 570+ Enterprise Edition or High Availability Edition systems</p> <p>Minimum operating system level: i5/OS V5R3</p>
#7260	<p>#7260 570 Enterprise Enablement</p> <p>The #7260 570 Enterprise Enablement is ordered when additional 5250 OLTP capability is required on a model 570 Enterprise Edition or High Availability Edition system. One additional processor's worth of 5250 OLTP capacity is authorized with each feature. This 5250 capacity can be used across multiple physical #8338 processors which have been permanently activated. An additional i5/OS license might be required.</p> <p>Supported on Model 570+ Enterprise Edition or High Availability Edition systems</p> <p>Minimum operating system level: i5/OS V5R3</p>
#7570	<p>#7570 On/Off Prepaid for Model 570 Capacity BackUp Edition</p> <p>The #7570 On/Off Prepaid for Model 570 Capacity BackUp Edition provides an account for 30 processor days of On/Off Capacity on Demand (On/Off Capacity on Demand). The system must be enabled for On/Off Capacity on Demand before ordering prepaid days</p>
#7577	<p>#7577 570 Enterprise Enablement</p> <p>The #7577 is ordered when additional 5250 OLTP capability is required on a permanently activated processor on a Model 570 Enterprise Edition server. An additional i5/OS license might be required.</p> <p>Minimum operating system level: i5/OS V5R3</p> <p>Supported on Model 570</p>
#7597	<p>#7597 570 Full Enterprise Enablement</p> <p>The #7597 is ordered when complete 5250 OLTP capability is required for all permanently activated processors on 5/8-way, 9/12-way and 13/16-way Model 570 Enterprise Edition servers. An additional i5/OS license might be required.</p> <p>Minimum operating system level: i5/OS V5R3</p> <p>Supported on Model 570</p>
#7618	<p>#7618 570 One Processor Activation</p> <p>The #7618 provides an activation code that can be used to permanently activate one additional processor on a Model 570+ CUoD server with #8338 Processor Feature. One or more activation features can be ordered, up to the maximum for the server.</p> <p>Supported on Model 570+ CUoD servers</p>
#7624	<p>#7624 570 On/Off Processor Day Billing</p> <p>The #7624 On/off Processor Day Billing is for temporary use of a processor on a daily base.</p> <p>Once an #7624 On/Off Processor Enablement feature is ordered and the associated enablement code is entered into the system, you must report your on/off usage to IBM at least monthly. This information, used to compute your billing data, is then provided to your sales channel. The sales channel places an order for a quantity of on/off processor day billing features and bills you. Order one #7624 for each billable processor day.</p> <p>Supported on Models 570+ with On/Off Processor Enablement feature</p> <p>Minimum operating system level: i5/OS V5R3</p>
#7663	<p>#7663 570 1GB Memory Activation</p> <p>The #7663 570 1GB Memory Activation provides the activation of 1 GB of additional Capacity on Demand memory. Multiple #7663 features are allowed up to the maximum CUoD memory of the server. Memory activations are stored in the server. If CUoD memory is moved to a different server, the additional activations remain with the original server.</p> <p>Supported on Models 570+ with CUoD memory available for activation</p> <p>Minimum operating system level: i5/OS V5R3</p>
#7728	<p>#7728 570 Reserve Capacity Prepaid</p> <p>The #7728 570 Reserve Capacity Prepaid provides 30 processor-days of reserve capacity on a Capacity on Demand server. To establish reserve capacity on the server, select a quantity of inactive processors to be placed in the server's shared processor pool as reserve processors. When the server recognizes that non-reserve processors (permanently activated processors) assigned and/or available to the uncapped partitions have been 100% utilized, a reserve processor is activated and a processor day (good for a 24-hour period) is subtracted from the prepaid amount of days.</p> <p>Supported on Models 570+ CUoD server with Reserve Capacity on Demand enabled</p> <p>Minimum operating system level: i5/OS V5R3</p>

#7738	<p>#7738 570 Base Processor Activation</p> <p>The #7738 570 Base Processor Activation provides an activation code that can be used to permanently activate one processor on a model 570 Capacity Upgrade on Demand system. One or more of these no-charge activation features can be ordered, depending on the configuration rules.</p> <p>Supported on Model 570+ CUoD server Minimum operating system level: i5/OS V5R3</p>
#7890	<p>#7890 Orderable on Demand Memory</p> <p>The #7890 Orderable on Demand Memory is used to order on demand memory. The #7890 provides 4 GB of activated memory and an additional 4 GB of memory available for activation. The 4 GB of additional memory can be activated in increments of 1 GB with #7950 and #7954 or #7957.</p> <p>Supported on Model 570 Minimum operating system level: i5/OS V5R3</p>
#7897	<p>#7897 570 CUoD Processor Activation</p> <p>The #7897 570 CUoD Processor Activation is used to order a password to permanently activate one additional processor on an #8961 or #8971 processor. One or more #7897s can be ordered on initial orders or via MES to activate additional processors.</p> <p>Supported on Model 570 Minimum operating system level: i5/OS V5R3 Customer Install Feature: Yes</p>
#7950	<p>#7950 On Demand Memory Activation for Model 570 (Permanent Activation)</p> <p>The #7950 On Demand Memory Activation for Model 570 provides the activation of 1 GB of additional CUoD memory on a CUoD server. Multiple #7950s are allowed on a CUoD server up to the maximum CUoD memory of the server. When ordered, a password to permanently activate memory in one GB increments is provided for a Model 570 with an #8961 or #8971 Processor. One or more #7950s can be ordered on initial orders or via MES to activate additional one GB memory increments.</p> <p>One or more #7890 4/8 GB DDR-1 Main Storage (#7890 Orderable on Demand Memory) with nonactivated memory features are required.</p> <p>Supported on Model 570 Minimum operating system level: i5/OS V5R3</p>
#7951	<p>#7951 On/Off Prepaid for Model 570</p> <p>The #7951 On/Off Prepaid for Model 570 is ordered to enable On/Off Capacity on Demand to temporarily enable processor or processors. When enabled, processors are requested on a temporary basis. An On/Off Capacity on Demand contract must be signed to order this feature. A #7951 can be reordered prior to reaching the enabled limit of usable temporary processor days.</p> <p>Available processors are required for activation. Supported on Model 570 Minimum operating system level: i5/OS V5R3</p>
#7952	<p>#7952 On/Off Capacity on Demand Billing</p> <p>A #7952 On/Off Capacity on Demand Billing feature code is used for On/Off Capacity on Demand billing for the temporary use of a processor on a daily basis. After a #7951 On/Off Capacity on Demand feature is ordered and the associated enablement code is installed on the system, On/Off Capacity on Demand usage must be reported monthly to IBM. Order one #7952 for each billable processor day that is used for temporary capacity.</p> <p>The number of processor days that are agreed to in the contract that is signed prior to ordering the On/Off Capacity on Demand feature is limited. A new contract is required to continue using temporary capacity after the initial limit has been reached and a second #7951 On/Off Capacity on Demand feature is ordered. An On/Off Capacity on Demand feature cannot be concurrently ordered with an On/Off Capacity on Demand billing feature.</p> <p>Supported on Model 570 Minimum operating system level: i5/OS V5R3</p>
#7954	<p>#7954 On Demand Memory for Model 570</p> <p>The #7954 On Demand Memory for Model 570 is ordered to enable On/Off Capacity on Demand. When enabled, memory activation can be requested on a temporary basis. An On/Off Capacity on Demand contract must be signed before the #7954 is ordered. The #7954 can be reordered prior to reaching the enabled limit of usable temporary memory days.</p> <p>One or more #7890 Orderable on Demand Memory with nonactivated memory are required. Supported on Model 570 Minimum operating system level: i5/OS V5R3</p>

#7956	<p>#7956 570 Reserve Capacity on Demand The #7956 570 Reserve Capacity on Demand provides 30 processor days of reserve capacity. After purchasing feature #7956, enter the resulting activation code and assign a quantity of the server's currently inactive processors to the shared processor pool as reserve capacity. When the server recognizes that the number of base (purchased or active) processors assigned across uncapped partitions is 100% utilized, and at least 10% of an additional processor is needed (based on multiple hits over a measured period), then a processor day (good for 24 hours) is deducted from the total number of prepaid processor days. Ordered via MES or as part of initial system order. A server with inactive (un-purchased) processor capacity is required. Supported on Model 570. Minimum operating system level: i5/OS V5R3</p>
#7957	<p>#7957 On Demand Memory Billing A #7957 On Demand Memory Billing feature code is used to bill for On/Off Capacity on Demand memory requests to use one GB of memory for one day (one 24-hour period). Begin reporting temporary memory usage to IBM at least once quarterly after a #7954 On/Off Memory Enablement feature is ordered and the associated enablement code is installed on the server. One #7957 must be ordered to pay for it's use (after the fact) for every GB day of memory requested during a billing period (a quarter). Ordered via MES. Supported on Model 570. Minimum operating system level: i5/OS V5R3</p>
#8452	<p>#8452 570 One Processor Activation The #8452 provides an activation code that can be used to permanently activate one additional processor on a Model 570. One or more of these no-charge activation features can be ordered, depending on the configuration rules. Supported on Model 570. Minimum operating system level: i5/OS V5R3</p>
#8459	<p>#8459 570 1 GB CUoD Memory activation The #8459 is ordered with 570 to 570 model upgrades when 1 GB of system memory activation is desired. Multiple #8459 are allowed. Supported on Model 570. Minimum operating system level: i5/OS V5R3</p>
#8470	<p>#8470 570 Base 1GB Memory Activation The #8470 570 Base 1GB Memory Activation activates one GB of main storage on a model 570+ system with Capacity on Demand memory. Depending on the on demand memory features ordered, several #8470s can be ordered. Supported on Model 570+ CoD memory Minimum operating system level: i5/OS V5R3</p>
#9286	<p>#9286 Base Enterprise Enablement The #9286 Base Enterprise Enablement is placed on an order of an Enterprise Edition server to enable one processor's worth of 5250 OLTP capability. Multiple #9286s can be on the order. Supported on Models 520 (9406 only), 550, 570, and 595 Minimum operating system level: i5/OS V5R3</p>
#9298	<p>#9298 Full Enterprise Enablement The #9298 Full Enterprise Enablement is ordered with 570-to-570 or 595-to-595 upgrades when the starting 570 or 595 configuration already has full enterprise enablement. It provides complete 5250 OLTP capability for all permanently activated processors on the upgraded Enterprise Edition server. Supported on Models 570 and 595 Minimum operating system level: i5/OS V5R3</p>
#9299	<p>#9299 Base Enterprise Enablement The #9299 Base Enterprise Enablement is placed on an order of an Enterprise Edition server to enable one processor's worth of 5250 OLTP capability. Multiple #9299s can be on the order. Supported on Model 520+, 550+, 570+, 595 1.9 GHz Enterprise Edition Minimum operating system level: i5/OS V5R3 with V5R3M5 LIC for 520+; V5R3 for 550+, 570+, 595 1.9 GHz</p>

2.15 IBM System i5 and eServer Model 595 processors

The Models 595+ and 595 initial installation is IBM installed. Processor upgrades within models are performed by IBM Service Representatives.

Processor	Processor Activation feature	Server feature	Edition feature	Model 595 1.9 GHz and 595 processor
#8966	#7815	#0940		26700/50500 CPW 8/16 Processor in Client/Server Environment <ul style="list-style-type: none"> ▶ Includes one #8966 with two 8-way POWER5 1.9 GHz processor (MCM) (CCIN 528C) ▶ Includes eight #8457 Base Processor Activation feature. ▶ Includes 36 MB L3 cache per processor node (MCM) ▶ Includes 16 main memory slots per processor card #8966.
			#7480	#7480 Standard Edition Provides limited 5250 OLTP CPW (CCIN 7480)
			#7481	#7481 Enterprise Edition Provides up to 50500 CPW for 5250 OLTP CPW (CCIN 7481)
			#7580	#7580 High Availability Edition Provides a High Availability Edition for a Model 595 with #0940 Server Feature (8/16-way) (CCIN 7580)
#8966	#7815	#0941		51000/92000 CPW 16/32 Processor in Client/Server Environment <ul style="list-style-type: none"> ▶ Includes two #8966 with four 8-way POWER5 1.9 GHz processor (MCM) (CCIN 528C) ▶ Includes 16 #8457 Base Processor Activation feature ▶ Includes 36 MB L3 cache per processor node (MCM) ▶ Includes 16 main memory slots per processor card #8966 (32 in total)
			#7482	#7482 Standard Edition Provides limited 5250 OLTP CPW (CCIN 7482)
			#7483	#7483 Enterprise Edition Provides up to 92000 CPW for 5250 OLTP CPW (CCIN 7483)
			#7581	#7581 High Availability Edition Provides a High Availability Edition for a Model 595 with #0941 Server Feature (16/32-way) (CCIN 7581)
#8966	#7815	#0943		92000/184000 CPW 32/64 Processor in Client/Server Environment <ul style="list-style-type: none"> ▶ Includes four #8966 with eight 8-way POWER5 1.9 GHz processor (MCM) (CCIN 528C) ▶ Includes thirty two #8457 595 Base Processor Activation features ▶ Includes 36 MB L3 cache per processor node (MCM) ▶ Includes 16 main memory slots per processor card #8966 (64 total)
			#7486	#7486 Standard Edition Provides limited 5250 OLTP CPW (CCIN 7486)
			#7487	#7487 Enterprise Edition Provides up to 184000 CPW for 5250 OLTP CPW (CCIN 7487)
			#7583	#7583 High Availability Edition Provides a High Availability Edition for a Model 595 with #0943 Server Feature (32/64-way) (CCIN 7583)
#8966	#7815	#0944		13600/92000 CPW 4/32-way processor in Client/Server Environment <ul style="list-style-type: none"> ▶ Includes two #8966 with four 8-way POWER5 1.9 GHz processor (MCM) (CCIN 528C) ▶ Includes 4 #8457 Base Processor Activation feature ▶ Includes 36 MB L3 cache per processor node (MCM) ▶ Includes 16 main memory slots per processor card #8966 (32 in total)
			#7590	#7590 Capacity BackUp Edition Provides a Capacity BackUp Edition for a Model 595 with #0944 Server Feature (4/32-way) (CCIN 7590)

Processor	Processor Activation feature	Server feature	Edition feature	Model 595 1.9 GHz and 595 processor
#8981	#7925	#0946		24500/45500 CPW 8/16 Processor in Client/Server Environment <ul style="list-style-type: none"> ▶ Includes one #8981 with two 8-way POWER5 1.65 GHz processor (MCM) (CCIN 52A4) ▶ Includes eight #8461 Base Processor Activation feature. ▶ Includes 36 MB L3 cache per processor node (MCM) ▶ Includes 16 main memory slots per processor card #8981
			#7496	#7496 Standard Edition Provides limited 5250 OLTP CPW (CCIN 7496)
			#7497	#7497 Enterprise Edition Provides up to 45500 CPW for 5250 OLTP CPW (CCIN 7497)
#8981	#7925	#0947		46000/85000 CPW 16/32 Processor in Client/Server Environment <ul style="list-style-type: none"> ▶ Includes two #8981 with four 8-way POWER5 1.65 GHz processor (MCM) (CCIN 52A4) ▶ Includes 16 #8461 Base Processor Activation feature ▶ Includes 36 MB L3 cache per processor node (MCM) ▶ Includes 16 main memory slots per processor card #8981 (32 in total)
			#7498	#7498 Standard Edition Provides limited 5250 OLTP CPW (CCIN 7498)
			#7499	#7499 Enterprise Edition Provides up to 85000 CPW for 5250 OLTP CPW (CCIN 7499)
#8981	#7925	#0952		86000/165000 CPW 32/64 Processor in Client/Server Environment <ul style="list-style-type: none"> ▶ Includes four #8981 with eight 8-way POWER5 1.65 GHz processor (MCM) (CCIN 52A4) ▶ Includes thirty two #8461 Base Processor Activation feature ▶ Includes 36 MB L3 cache per processor node (MCM) ▶ Includes 16 main memory slots per processor card #8981 (64 total)
			#7984	#7984 Standard Edition Provides limited 5250 OLTP CPW (CCIN 7984)
			#7985	#7985 Enterprise Edition Provides up to 165000 CPW for 5250 OLTP CPW (CCIN 7985)

Model 595+ and 595 CUoD and OLTP features	
#7259	#7259 595 Full Enterprise Enablement The #7259 595 Full Enterprise Enablement is ordered when complete 5250 OLTP capability is required for all permanently activated processors on a 8/16-way, 16/32-way and 32/64-way Model 595 Enterprise Edition or High Availability Edition system. An additional i5/OS license might be required.
#7261	#7261 595 Enterprise Enablement A #7261 595 Enterprise Enablement is ordered when additional 5250 OLTP capability is required on a Model 595 Enterprise Edition or High Availability Edition system. One additional processor's worth of 5250 OLTP capacity is authorized with each feature. This 5250 capacity can be used across multiple physical #8966 processors are permanently activated. An additional i5/OS license might be required.
#7496	#7496 Standard Edition for #0946 The #7496 Standard Edition for #0946 is ordered when a Standard Edition of a Model 595 system with #0946 8/16-way Server Feature is required. Minimum operating system level: i5/OS V5R3 Customer Install Feature: No
#7497	#7497 Enterprise Edition for #0946 The #7497 Enterprise Edition for #0946 is ordered when an Enterprise Edition of a Model 595 system with #0946 8/16-way Server Feature is required. Minimum operating system level: i5/OS V5R3 Customer Install Feature: No
#7498	#7498 Standard Edition for #0947 The #7498 Standard Edition for #0947 is ordered when a Standard Edition of a Model 595 system with #0947 16/32-way Server Feature is required. Minimum operating system level: i5/OS V5R3 Customer Install Feature: No

#7499	<p>#7499 Enterprise Edition for #0947 The #7499 is ordered when an Enterprise Edition of a Model 595 system with #0947 16/32-way Server Feature is required. Minimum operating system level: i5/OS V5R3 Customer Install Feature: No</p>
#7579	<p>#7579 595 Enterprise Enablement The #7579 595 Enterprise Enablement is ordered when additional 5250 OLTP capability is required on a permanently activated processor on a Model 595 Enterprise Edition server. An additional i5/OS license might be required. Minimum operating system level: i5/OS V5R3 Customer Install Feature: Yes</p>
#7598	<p>#7598 595 Full Enterprise Enablement The #7598 595 Full Enterprise Enablement is ordered when complete 5250 OLTP capability is required for all permanently activated processors on Model 595 Enterprise Edition servers. An additional i5/OS license might be required. Minimum operating system level: i5/OS V5R3 Initial order only</p>
#7799	<p>#7799 595 256GB Memory Activation The #7799 595 256GB Memory Activation provides the activation of 256GB of additional CUoD memory on a CUoD server. Multiple #7799s are allowed on a CUoD server up to the maximum CUoD memory of the server. A CUoD server with memory available for activation must be available. Minimum operating system level: i5/OS V5R3, SUSE Linux Enterprise Server 9 for POWER or Red Hat Enterprise Linux AS for POWER Version 3 Ordered via MES or as part of initial system order Supported on Model 595 Customer Install Feature: Yes</p>
#7815	<p>#7815 595 One Processor Activation Ordering the #7815 595 One Processor Activation feature results in an activation code that can be used to permanently activate one additional processor on a model 595 CUoD server with #8966 Processor Feature. One or more activation features can be ordered, up to the maximum for the server. Supported on Model 595.</p>
#7839	<p>#7839 595 On/Off Processor Enablement The #7839 595 On/Off Processor Enablement feature is ordered to temporarily enable a Model 595 for On/Off Capacity on Demand. When enabled, processors are requested on a temporary basis. An On/Off Capacity on Demand contract must be signed prior to ordering a #7839. The #7839 can be reordered prior to reaching the enabled limit of usable temporary processor days. Supported on Model 595.</p>
#7925	<p>#7925 595 One Processor Activation Ordering the #7925 595 One Processor Activation feature results in an activation code that can be used to permanently activate one additional processor on a Model 595 with #8981 Processor Feature. One or more activation features can be ordered. Ordered via MES or as part of initial system order. Customer Install Feature: Yes</p>
#7926	<p>#7926 595 Reserve Capacity Prepaid The #7926 595 Reserve Capacity Prepaid provides 30 processor-days of reserve capacity on a CUoD server. To establish reserve capacity on the server, select a quantity of inactive processors to be placed in the server's Shared Processor Pool as reserve processors. When the server recognizes that permanently activated processors assigned or available to the uncapped partitions have been 100% utilized, a processor day (good for a 24-hour period) is subtracted from the prepaid amount of days. CUoD server with Reserve Capacity on Demand enabled Model 595 is required. Ordered via MES or as part of initial system order Minimum operating system level: i5/OS V5R3, SUSE Linux Enterprise Server 9 for POWER or Red Hat Enterprise Linux AS for POWER Version 3 Customer Install Feature: Yes</p>
#7970	<p>#7970 595 1GB Memory Activation The #7970 595 1GB Memory Activation provides the activation of 1 GB of additional CUoD memory on a CUoD server. Multiple #7970 features are allowed on a CUoD server up to the maximum CUoD memory of the server. CUoD 595 server with memory available for activation is required. Supported on Model 595. Customer Install Feature: Yes</p>

#7971	<p>#7971 595 On/Off Processor Enablement</p> <p>The #7971 595 On/Off Processor Enablement is ordered to enable your server for On/Off Capacity on Demand on a model 595 with #8966 Processor Feature. Once enabled, you can request processors on a temporary basis. You must sign an On/Off Capacity on Demand contract before you order this feature. Prior to reaching your enabled limit of usable temporary processor days, you can reorder this feature. Supported on Model 595.</p>
#7972	<p>#7972 595 On/Off Processor Day Billing</p> <p>Once an On/Off Processor Enablement feature is ordered and the associated enablement code is entered into the system, you must report your on/off usage to IBM at least monthly. This information, used to compute your billing data, is then provided to your sales channel. The sales channel places an order for a quantity of on/off processor day billing features and bill you. Order one #7972 for each billable processor day on a model 595 with #8966 Processor Feature. Supported on Model 595.</p>
#7973	<p>#7973 595 On/Off Memory Enablement</p> <p>The #7973 595 On/Off Memory Enablement is ordered to enable On/Off Capacity on Demand. When enabled, memory is activated on a temporary basis. An On/Off Capacity on Demand contract must be signed before this feature is ordered. The #7973 can be re-ordered prior to reaching the enabled limit of usable temporary memory days. Supported on Model 595. Customer Install Feature: Yes</p>
#7974	<p>#7974 595 1GB Memory Day Billing</p> <p>When an On/Off Memory Enablement feature is ordered and the associated enablement code is entered into the system, on/off usage must be reported to IBM at least monthly. Order one #7974 595 1GB Memory Day Billing for each billable memory day. Supported on Model 595. Customer Install Feature: Yes</p>
#7975	<p>#7975 595 Reserve Capacity Prepaid</p> <p>A #7975 595 Reserve Capacity Prepaid provides 30 processor-days of reserve capacity on a Capacity Upgrade on Demand (CUoD) server. To establish reserve capacity on the server, select a quantity of inactive processors to be placed in the server's shared processor pool as reserve processors. When the server recognizes that non-reserve processors (permanently activated processors) assigned and/or available to the uncapped partitions have been 100% utilized, a processor day (good for a 24-hour period) is subtracted from the prepaid amount of days. Supported on Model 595.</p>
#7984	<p>#7984 Standard Edition for #0952</p> <p>The #7984 Standard Edition for #0952 is ordered when a Standard Edition of a Model 595 system with #0952 32/64-way Server Feature is required. Supported on Model 595. Minimum operating system level: i5/OS V5R3 Customer Install Feature: No</p>
#7985	<p>#7985 Enterprise Edition for #0952</p> <p>The #7985 Enterprise Edition for #0952 is ordered when an Enterprise Edition of a Model 595 system with #0952 32/64-way Server Feature is required. Ordered via MES or as part of initial system order. Supported on Model 595. Minimum operating system level: i5/OS V5R3 Customer Install Feature: No</p>
#7993	<p>#7993 595 On/Off Processor Day Billing</p> <p>Report on/off usage to IBM at least monthly once an On/Off Processor Enablement feature is ordered and the associated enablement code is entered into the system. Order one #7993 595 On/Off Processor Day Billing for each billable processor day. Ordered via MES Supported on Model 595. Customer Install Feature: Yes</p>
#8457	<p>#8457 595 Base Processor Activation</p> <p>The #8457 595 Base Processor Activation provides an activation code that can be used to permanently activate one processor on a model 595 system with #8966 Processor Feature. One or more of these no-charge activation features can be ordered, depending on the configuration rules. Supported on Model 595.</p>

#8460	<p>#8460 595 1GB CUoD Memory Activation</p> <p>The #8460 595 1GB CUoD Memory Activation is ordered with Model 595 to Model 595 upgrades when one GB of system memory activation is desired. Multiple #8460 are allowed.</p> <p>Ordered via MES or as part of initial system order</p> <p>Supported on Model 595.</p> <p>Customer Install Feature: Yes</p>
#8461	<p>#8461 Base One Processor Activation</p> <p>The #8461 Base One Processor Activation provides base activation code that is used to permanently activate processor on a Model 595 server with #8981 Processor Feature. One or more of these no charge activation features is ordered, depending on the configuration rules.</p> <p>Ordered via MES or as part of initial system order</p> <p>Supported on Model 595.</p> <p>Customer Install Feature: Yes</p>
#8966	<p>#8966 595 1.9 Ghz Processor 0/16-way</p> <p>The #8966 595 1.9 Ghz Processor 0/16-way provides a 0/16-way POWER5 processor book for the Model 595. The 1.9 GHz processors are packaged on two 8-way Multi Chip Modules (MCMs). The first #8966 in the system provides seven RIO-G adapter slots and subsequent #8966s provide eight RIO-G adapter slots. The #8966 has 16 memory card slots and a minimum of four memory features (four memory cards) are required for each processor book.</p> <p>Supported on Model 595.</p>
#9286	<p>#9286 Base Enterprise Enablement</p> <p>The #9286 is placed on an order of an Enterprise Edition server to enable one processor's worth of 5250 OLTP capability. Multiple #9286s can be on the order.</p> <p>Supported on Models 520 (9406 only), 550, 570, and 595</p> <p>Minimum operating system level: i5/OS V5R3</p>
#9298	<p>#9298 Full Enterprise Enablement</p> <p>The #9298 Full Enterprise Enablement is ordered with a Model 570 to Model 570 or Model 595 to Model 595 upgrades when the starting Model 570 or 595 configuration already has full enterprise enablement. It provides complete 5250 OLTP capability for all permanently activated processors on the upgraded Enterprise Edition server.</p> <p>Ordered via MES</p> <p>Minimum operating system level: i5/OS V5R3</p> <p>Customer Install Feature: Yes</p>
#9299	<p>#9299 Base Enterprise Enablement</p> <p>A #9299 Base Enterprise Enablement is placed on an order of an Enterprise Edition server to enable one processor's worth of 5250 OLTP capability. Multiple #9299s can be on the order.</p> <p>Minimum operating system level: i5/OS V5R3</p> <p>Customer Install Feature: Yes</p>

2.16 IBM System i5 and eServer i5 features

You can find feature descriptions, including details about power and packaging, main storage, PCI IOP controllers, workstation controllers, LAN/WAN adapters, disk units, internal tape, CD-ROM, and other magnetic media controllers in Chapter 4, "IBM System i5, eServer i5, and iSeries features and placement" on page 97.

2.17 Supported upgrades for System i5 and eServer i5 models

Refer to 1.1, "Upgrades for System i processors" on page 2 for an overview of the upgrades supported for System i5 and eServer i5 models.

iSeries 800, 810, 825, 870, and 890 models

This chapter provides the summary charts, diagrams, and identifies the processor features that are associated with each iSeries 800, 810, 825, 870, and 890 server. You can find feature descriptions, including details about power and packaging and main memory, in Chapter 4, “IBM System i5, eServer i5, and iSeries features and placement” on page 97.

Model	Processor	Announce date	General availability date	Withdrawn from marketing
800	#2463, #2464	28 January 2003	28 February 2003	01 October 2005
810	#2465	13 May 2003	23 May 2003	01 October 2005
	#2466, #2467, #2469	28 January 2003	28 February 2003	01 October 2005
825	#2473	28 January 2003	28 February 2003	01 October 2005
	#2495, #2496	5 September 2003	12 September 2003	01 October 2005
870	#2486	28 January 2003	28 February 2003	01 October 2005
	#2489	22 July 2003	30 July 2003	01 October 2005
890	#0197, #0198, #2487, #2488	14 May 2002	30 August 2002	07 May 2003
	#2497, #2498	28 January 2003	28 February 2003	01 October 2005
	#2499	5 September 2003	12 September 2003	01 October 2005

Note: The darker shading in the following tables and figures represents the base configuration of the system. The capacities shown might require prerequisites. Some combinations of features are not valid

3.1 iSeries Model 800 overview

The following tables provide the minimum and maximum system capacities for the Model 800.

Processor feature	Model 800		
	#2463		#2464
	#0863	#0864	#0865
Server feature			
Relative system performance ^{1, 2}			
Processor CPW	300	300	950
5250 CPW			
Value and Standard ^{6a}	25	25	-
Advanced ^{6a}	-	-	50
Number/type/speed of processor	1/SStar/540 MHz	1/SStar/540 MHz	1/SStar/540 MHz
L2 Cache (MB)	0	0	2
Main storage (MB minimum to maximum)	256 to 8192	512 to 8192 ^{9a}	512 to 8192 ^{9a}
Main storage DIMMs (minimum/maximum)	1/8	1/8	1/8
Minimum OS/400@ level ^{8a}	V5R2	V5R2	V5R2
Software group ^{6a}	P05	P05	P10

Numbers are for all 800 processor features	Base system	#7116 System Unit Expansion	#5095/#0595 PCI-X Expansion Tower	#5094 PCI-X Expansion Tower	Total system maximum
Disk storage (GB)					
Integrated minimum	17.5	17.5	17.5	17.5	
Integrated maximum	423.3	846.7	846.7	3175.2	4445
External maximum ⁷	-	-	-	-	4375
Total maximum	-	-	-	-	4445
DASD arms maximum	6	12	12	45	63
Internal arms	6	12	12	45	63
External LUNs	-	-	-	-	62
Physical packaging					
External HSL ports	2	-	-	-	2
External HSL loops	1	-	-	-	1
PCI-X Expansion Tower	1	-	-	-	1
External xSeries Servers	3	-	-	-	3
Embedded IOP	1	-	-	-	1
PCI card slots	7	-	7	14	21
Maximum PCI IOA cards	6	-	5	11	17
Communication lines ³	18	-	20	44	60
LAN ports	3	-	5	8	11
Integrated xSeries Servers ^{10a}	1	-	1	3	4
Twinaxial workstation controllers	4	-	5	11	15
Twinaxial workstations	160	-	200	440	600
Internal CD/DVD/tape ⁴	2	-	-	2	4
External tape	4	-	5	11	15
External optical/CD/DVD	4	-	5	11	15
Cryptographic coprocessor	4	-	3	4	4
Cryptographic accelerator	2	-	2	2	2

To review the footnotes for this table, see 3.6, "Notes for iSeries Models 800, 810, 825, 870, and 890 overview" on page 68.

3.2 iSeries Model 810 overview

The following tables provide the minimum and maximum system capacities for the Model 810.

Processor feature	Model 810			
	#2465	#2466	#2467	#2469
Server feature	#0868	#0866	#0867	#0869
Relative system performance ^{1, 2}				
Processor CPW	750	1020	1470	2700
5250 CPW ^{5a}				
Standard ^{6b}	0	0	0	0
Enterprise ^{6b}	750	1020	1470	2700
High Availability ^{6b}	750	1020	1470	2700
Number/type/speed of processor	1/SStar/540 MHz	1/SStar/540 MHz	1/SStar/750 MHz	2/SStar/750 MHz
L2 Cache (MB) per processor	2	2	4	4
Main storage (MB minimum to maximum)	512 to 16384	512 to 16384	512 to 16384	512 to 16384
Main storage DIMMs (minimum/maximum)	1/8	1/8	1/8	2/16
Minimum OS/400 level ^{8b}	V5R2	V5R2	V5R2	V5R2
Software group ^{6b}	P10	P10	P10	P20

The following tables provide the minimum and maximum system capacities for the Model 810 iSeries for Domino.

Processor feature	Model 810 iSeries for Domino		
	#2466	#2467	#2469
Server feature ^{9c}	#0769	#0770	#0771
Relative system performance ^{1, 2}			
Processor CPW	1020	1470	2700
Mail and Calendar Users (MCU) ^{2a}	3100	4200	7900
5250 CPW ^{5a}			
Domino ^{6b}	0	0	0
Number/type/speed of processor	1/SStar/540 MHz	1/SStar/750 MHz	2/SStar/750 MHz
L2 Cache (MB) per processor	2	4	4
Main storage (GB minimum to maximum) ^{9b}	1.5 to 16	3.5 to 16	5.5 to 16
Main storage DIMMs (maximum)	8	8	16
Minimum OS/400 level ^{8b}	V5R2	V5R2	V5R2
Software group ^{6b}	P10	P10	P20

Numbers are for all 810 processor features	Base system	#7116 System Unit Expansion	#5095/#0595 PCI-X Expansion Tower	#5094 PCI-X Expansion Tower	Total system maximum
Disk storage (GB)					
Integrated minimum	17.5	17.5	17.5	17.5	
Integrated maximum	423.3	846.7	846.7	3172.5	13971
External maximum ⁷	-	-	-	-	13901
Total maximum	-	-	-	-	13971
DASD arms maximum	6	12	12	45	198
Internal arms	6	12	12	45	198
External LUNs	-	-	-	-	197
Physical packaging					
External HSL ports	2	-	-	-	-
External HSL loops	1	-	-	-	1
PCI/PCI-X Expansion Tower	4	-	-	-	4
External xSeries Servers	7	-	-	-	7
Embedded IOP	1	-	-	1	5
PCI card slots	7	-	7	14	63
Maximum PCI IOA cards	6	-	5	11	50
Communication lines ³	18	-	20	44	192
LAN ports	3	-	5	11	36
Integrated xSeries Servers	1	-	1	3	13
Twinaxial workstation controllers	4	-	5	11	48
Twinaxial workstations	160	-	200	440	1920
Internal CD/DVD/tape ⁴	2	-	-	2	10
External tape	4	-	5	11	18
External optical/CD/DVD	4	-	5	11	18
Cryptographic coprocessor	4	-	3	8	8
Cryptographic accelerator	2	-	2	2	2

To review the footnotes for this table, see 3.6, "Notes for iSeries Models 800, 810, 825, 870, and 890 overview" on page 68.

3.3 iSeries Model 825 overview

The following tables provide the minimum and maximum system capacities for the Model 825.

Processor feature	Model 825			
	#0873	#2473	#2495	#0890
Server feature ⁷	-	-	-	-
Server feature for Domino ^{9c}	-	#0772	#0773	-
Relative system performance ^{1, 2}				
Processor CPW	3600/6600	-	-	1250/6600
Mail and Calendar Users (MCU) ^{2a}	-	11600	17400	-
5250 CPW ^{5b}				
Standard and Domino ^{6c}	-	0	0	-
Enterprise ^{6c}	Maximum	-	-	-
High Availability ^{6c}	Maximum	-	-	-
Capacity Backup ^{6c}	-	-	-	Maximum
Number/type/speed of processor	3/6 / POWER4/ 1.1 GHz	4 / POWER4/ 1.1 GHz	6 / POWER4™ 1.1 GHz	1/6 / POWER4/ 1.1 GHz
L3 Cache (MB per processor)	16	16	16	16
L2 Cache (MB per processor)	0.72	0.72	0.72	0.72
Main storage (GB minimum to maximum) ^{9b}	2 to 48	6 to 48	12 to 48	2 to 48
Main storage DIMMs (minimum/maximum)	8/24	8/24	8/24	8/24
Minimum OS/400 level ^{8b}	V5R2	V5R2	V5R2	V5R2
Software group ^{6c}	P30	P30	P30	P30

Numbers are for all 825 processor features	Base system	#5095/#0595 PCI-X Expansion Tower	#5094 PCI-X Expansion Tower	Total maximum
Disk storage (GB) ^{9b}				
Integrated minimum	17.5	-	-	17.5
Integrated maximum	1058.4	846.7	3175.2	58216
External maximum ⁷	-	-	-	58145
Total maximum	-	-	-	58216
DASD arms maximum				
Internal arms	15	12	45	825
External LUNs	-	-	-	824
Physical packaging				
External RIO-G ports	6	-	-	6
External RIO-G loops	3	-	-	3
PCI Expansion Towers	16	-	-	16
PCI-X Expansion Towers	18	-	-	18
External xSeries Servers	18	-	-	18
Embedded IOP	1	-	1	19
Embedded IOA	1	-	-	1
PCI card slots	10	7	14	262
Maximum PCI IOA cards	8	5	11	205
Communication lines ^{3a}	30	20	44	320
LAN ports	6	5	11	96
Integrated xSeries Servers	1	1	3	36
Twinaxial workstation controllers	5	5	11	135
Twinaxial workstations	200	200	440	5400
Internal CD-ROM/DVD-RAM/tape ⁴	2	-	2	18
External tape/optical/CD/DVD	5	5	11	18
Cryptographic coprocessor	5	3	8	8
Cryptographic accelerator	4	4	4	4

To review the footnotes for this table, see 3.6, “Notes for iSeries Models 800, 810, 825, 870, and 890 overview” on page 68.

3.4 iSeries Model 870 overview

The following tables provide the minimum and maximum system capacities for the Model 870.

Processor feature	Model 870		
	#2486	#2489	#2496
Server feature	#0886	#0889	#0891
Relative system performance ^{1, 2}			
Processor CPW	11500/20000	7700/11500	3200/20000
5250 CPW ^{5c}			--
Standard ^{6d}	0	0	0
Enterprise ^{6d}	Maximum	Maximum	--
High Availability ^{6d}	Maximum	Maximum	--
Capacity BackUp ^{6d}	--	--	Maximum
Number/type/speed of processor	8/16 / POWER4/1.3 GHz	5/8 / POWER4/1.3 GHz	2/16 / POWER4/1.3 GHz
L2 and L3 Cache (MB/processor)	16.72	16.72	16.72
Main storage (GB minimum to maximum)	8 to 128	8 to 64	8 to 128
Main storage cards (minimum/maximum)	2/4	2/2	2/4
Minimum OS/400 level ^{8b}	V5R2	V5R2	V5R2
Software group ^{6d}	P40	P40	P40

Numbers are for all 870 processor features	#9094 Base Tower	#5095/#0595 PCI-X Expansion Tower	#5094 PCI-X Expansion Tower	Total system maximum
Disk storage (GB)				
Integrated minimum	17.5	17.5	17.5	
Integrated maximum	3175.2	846.7	3175.2	144446
External maximum ⁷	-	-	-	144375
Total maximum	-	-	-	144446
DASD arms maximum				
Internal arms	45	12	45	2047
External LUNs	-	-	-	2046
Physical packaging				
External HSL/RIO-G ports	-/16	-	-	-/16
External HSL/RIO-G loops	-/8	-	-	-/8
PCI/PCI-X Expansion Towers	47	-	-	47
External xSeries Servers	60	-	-	60
Embedded IOP	-	-	-	-
Embedded IOA	-	-	-	-
PCI card slots	14	7	14	672
Maximum PCI IOA cards	11	5	11	528
Communication lines ³	38	20	44	480
LAN ports	7	5	8	128
Integrated xSeries Servers	2	1	3	48
Twinaxial workstation controllers	9	5	11	180
Twinaxial workstations	360	200	440	7200
Internal CD/DVD/tape ^{4a}	2	-	2	26
External tape/optical/CD/DVD	9	5	11	26
Cryptographic coprocessor	8	3	8	32
Cryptographic accelerator	4	4	4	8

To review the footnotes for this table, see 3.6, “Notes for iSeries Models 800, 810, 825, 870, and 890 overview” on page 68.

3.5 iSeries Model 890 overview

The following tables provide the minimum and maximum system capacities for the Model 890.

Processor feature	Model 890		
	#2497	#2498	#2499
Server feature	#0897	#0898	#0892
Relative system performance ^{1, 2}			
Processor CPW	20000/29300	29300/37400	5600/37400
5250 CPW ^{5c}			
Standard ^{6e}	0	0	0
Enterprise ^{6e}	Maximum	Maximum	-
High Availability ^{6e}	Maximum	Maximum	-
Capacity Backup ^{6e}	-	-	Maximum
Number/type/speed of processor	16/24 / POWER4/1.3 GHz	24/32 / POWER4/1.3 GHz	4/32 / POWER4/1.3 GHz
L2 and L3 Cache (MB/processor)	16.72	16.72	16.72
Main storage (GB minimum to maximum)	8 to 192	16 to 256	16 to 256
Main storage cards (minimum/maximum)	2/6	4/8	4/8
Minimum OS/400 level ^{8b}	V5R2	V5R2	V5R2
Software group ^{6e}	P50	P50	P50

Processor feature	Model 890			
	#2487	#2488	#0197	#0198
Relative system performance ^{1, 2}				
Processor CPW	20200 - 29300	29300 - 37400	29300	37400
5250 CPW ^{5c}			0	0
#1576 (Base)	120	120	-	-
#1577	240	240	-	-
#1578	560	560	-	-
#1579	1050	1050	-	-
#1581	2000	2000	-	-
#1583	4550	4550	-	-
#1585	10000	10000	-	-
#1587	16500	16500	-	-
#1588	20200	20200	-	-
#1591	-	37400	-	-
Number/type/speed of processor	16/24/ POWER4/ 1.3 GHz	24/32/ POWER4/ 1.3 GHz	24/POWER4/ 1.3 GHz	32/POWER4/ 1.3 GHz
L2 Cache (MB)	1.5 MB/chip set	1.5 MB/chip set	1.5 MB/chip set	1.5 MB/chip set
L2 and L3 Cache (MB/processor)	16.72	16.72	16.72	16.72
Main storage (GB minimum to maximum)	16 to 192	24 to 256	16 to 192	24 to 256
Main storage cards (minimum/maximum)	2/6	4/8	2/6	4/8
Minimum OS/400 level ^{8b}	V5R2	V5R2	V5R2	V5R2

	Model 890			
Software group ^{6e}	P50 or P60	P50 or P60	P50	P50

Archived

Numbers are for all 890 processor features	#9094 Base Tower	#5095/#0595 PCI-X Expansion Tower	#5094 PCI-X Expansion Tower	Total maximum
Disk storage (GB)				
Integrated minimum	17.5	17.5	17.5	
Integrated maximum	3172.5	846.7	3175.2	144446
External maximum ⁷	11290	3175	13548	144375
Total maximum	14462	4021	16720	144446
DASD arms maximum				
Internal arms	45	12	45	2047
External LUNs	160	127	192	2046
Physical packaging				
External HSL/RIO-G ports	-/24	-	-	-/24
External HSL/RIO-G loops	-/12	-	-	-/12
PCI/PCI-X Expansion Towers	47	-	-	47
External xSeries Servers	60	-	-	60
Embedded IOP	-	-	-	-
Embedded IOA	-	-	-	-
PCI card slots	14	7	14	672
Maximum PCI IOA cards	11	5	11	528
Communication lines ³	38	20	44	480
LAN ports	7	5	8	128
Integrated xSeries Servers	2	1	3	48
Twinaxial workstation controllers	9	5	11	180
Twinaxial workstations	360	200	440	7200
Internal CD-ROM/DVD-RAM/tape ^{4a}	2	-	2	26
External tape/optical/CD/DVD	9	5	11	26
Cryptographic coprocessor	8	3	8	32
Cryptographic accelerator	4	4	4	8

To review the footnotes for this table, see 3.6, “Notes for iSeries Models 800, 810, 825, 870, and 890 overview” on page 68.

3.6 Notes for iSeries Models 800, 810, 825, 870, and 890 overview

Note 1	Commercial Processing Workload (CPW) is used to measure the performance of all iSeries and AS/400e processors announced from September 1996 onward. The CPW value is measured on maximum configurations. The type and number of disk devices, the number of workstation controllers, the amount of memory, the system model, other factors, and the application running determine what performance is achievable.
Note 2	Processor performance represents the relative performance (maximum capacity) of a processor feature running CPW in a client/server environment. Processor capacity is achievable when the commercial workload is not constrained by main storage and direct access storage device (DASD). Performance of the 5250 CPW represents the relative performance available to perform host-centric workloads. The amount of in 5250 CPW capacity consumed reduces the available processor capacity by the same amount.
Note 2a	Mail and Calendar Users (MCU) is a relative performance measurement derived by performing mail and calendar functions using Domino and Notes clients. The MCU workload represents concurrent users on a Notes client who are reading, updating, or deleting documents in an e-mail database. It also represents users who are performing lookups in the Domino Directory, and scheduling calendar appointments and invitations. Reported values reflect 70% processor utilization to allow for growth and peak loads in excess of customer workload estimates.

Note 3	One line is used if #5544 System Console on Operations Console is used. One line can be used if #5546 System Console on 100 Mbps Token Ring or #5548 System Console on 100 Mbps Ethernet is selected and the #0367 Operations Console PCI Cable is connected.
Note 3a	One line is used if #5544 System Console on Operations Console is used. One line can be used if #5548 System Console on 100 Mbps Ethernet is selected and the #0367 Operations Console PCI Cable is connected.
Note 4	There must be one DVD-ROM or DVD-RAM per system.
Note 4a	There must be one DVD-RAM or DVD-ROM in the #9094 Base PCI I/O Enclosure.
Note 5a Model 810	<p>5250 CPW (Interactive) is an approximate value that reflects the amount of Processor CPW that can be used for workloads performing 5250-based tasks. Remember that:</p> <ul style="list-style-type: none"> ▶ The iSeries Enterprise Edition provides maximum 5250 CPW support (up to 100% of the capacity of the active processor CPW). The iSeries Standard Edition provides zero CPW for 5250 work. ▶ Any task that uses a 5250 data stream is considered 5250 online transaction processing (OLTP) work and requires some amount of 5250 CPW to process no matter how the task was started. ▶ A task submitted through a 5250 session (5250 device or 5250 emulation) that does display or printer input/output (I/O) requires 5250 CPW. ▶ A task submitted through a 5250 session (5250 device or 5250 emulation) as a “batch” job is not considered 5250 OLTP work and does not require any 5250 CPW unless the task does display or printer I/O. ▶ Limited 5250 CPW is available with the Standard Edition for a system administrator to use 5250 display device I/O to manage various aspects of the server. Multiple administrative jobs exceed this capability.
Note 5b Model 825	<p>5250 CPW (Interactive) is an approximate value that reflects the amount of Processor CPW that can be used for workloads performing 5250-based tasks. Remember that:</p> <ul style="list-style-type: none"> ▶ The iSeries Enterprise Edition provides maximum 5250 CPW support (up to 100% of the capacity of the active processor CPW). The iSeries Standard Edition provides limited CPW for 5250 work. ▶ Any task that uses a 5250 data stream is considered 5250 OLTP work and requires some amount of 5250 CPW to process no matter how the task was started. ▶ A task submitted through a 5250 session (5250 device or 5250 emulation) that does display or printer I/O requires 5250 CPW. ▶ A task submitted through a 5250 session (5250 device or 5250 emulation) as a “batch” job is not considered 5250 OLTP work and does not require any 5250 CPW unless the task does display or printer I/O. ▶ Limited 5250 CPW is available with the Standard Edition for a system administrator to use 5250 display device I/O to manage various aspects of the server. Multiple administrative jobs exceed this capability. ▶ Maximum 5250 CPW is equivalent to the processor CPW for the active processor.
Note 5c Models 870 890	<p>5250 CPW (Interactive) is an approximate value that reflects the amount of Processor CPW that can be used for workloads performing 5250-based tasks. Remember that:</p> <ul style="list-style-type: none"> ▶ The iSeries Enterprise Edition provides maximum 5250 CPW support (up to 100% of the capacity of the active processor CPW). The iSeries Standard Edition provides zero CPW for 5250 work. ▶ Any task that uses a 5250 data stream is considered 5250 OLTP work and requires some amount of 5250 CPW to process no matter how the task was started. ▶ A task submitted through a 5250 session (5250 device or 5250 emulation) that does display or printer I/O requires 5250 CPW. ▶ A task submitted through a 5250 session (5250 device or 5250 emulation) as a “batch” job is not considered 5250 OLTP work and does not require any 5250 CPW unless the task does display or printer I/O. ▶ Limited 5250 CPW is available with the Standard Edition for a system administrator to use 5250 display device I/O to manage various aspects of the server. Multiple administrative jobs exceed this capability. ▶ Maximum 5250 CPW is equivalent to the processor CPW for the active processor.

Note 6a Model 800	Software group is determined by the combination of Processor feature and Edition feature. This table provides a cross reference. Display the QPRCFEAT system value on DSPHDWRSC TYPE(*AHW) to display the processor feature code value.					
	Processor	Server feature	Edition feature	Software group	Processor feature code or QPRCFEAT value	
	#2463	#0863	#7400 Value	P05	7400	
		#0864	#7400 Standard	P05	7400	
#2464	#0865	#7408 Advanced	P10	7408		
Note 6b Model 810	Software group is determined by the combination of Processor feature and Edition feature. This table provides a cross reference. Display the QPRCFEAT system value on DSPHDWRSC TYPE(*AHW) to display the processor feature code value.					
	Processor	Server feature	Edition feature	Software group	Processor feature code or QPRCFEAT value	
	#2465	#0868	#7404 Standard	P10	7404	
			#7406 Enterprise	P10	7406	
			#7445 High Availability	P10	7406	
	#2466	#0866	#7407 Standard	P10	7407	
			#7409 Enterprise	P10	7409	
			#7446 High Availability	P10	7409	
		#0769	#7407 Domino	P10	7407	
	#2467	#0867	#7410 Standard	P10	7410	
			#7412 Enterprise	P10	7412	
			#7447 High Availability	P10	7412	
		#0770	#7410 Domino	P10	7410	
	#2469	#0869	#7428 Standard	P20	7428	
			#7430 Enterprise	P20	7430	
			#7448 High Availability	P20	7430	
		#0771	#7428 Domino	P20	7428	
	Note 6c Model 825	Software group is determined by the combination of Processor feature and Edition feature. This table provides a cross reference. Display the QPRCFEAT system value on DSPHDWRSC TYPE(*AHW) to display the processor feature code value. This value is also shown for the Capacity Card CCIN value when using SST to display system capacity information.				
		Processor feature	Server feature	Edition feature	Software group	Processor feature code or QPRCFEAT value
#2473		#0873	#7416 Standard	P30	7416	
			#7418 Enterprise	P30	7418	
			#7434 High Availability	P30	7418	
		#0772	#7416 Domino	P30	7416	
		#0773	#7416 Domino	P30	7416	
#2495	#0890	#7439 Capacity BackUp	P30	7439		

Note 6d Model 870	Software group is determined by the combination of Processor feature and Edition feature. This table provides a cross reference. Display the QPRCFEAT system value on DSPHDWRSC TYPE(*AHW) to display the processor feature code value. This value is also shown for the Capacity Card CCIN value when using SST to display system capacity information.				
	Processor feature	Server feature	Edition feature	Software group	Processor feature code or QPRCFEAT value
	#2486	#0886	#7419 Standard	P40	7419
			#7421 Enterprise	P40	7421
			#7436 High Availability	P40	7421
	#2489	#0889	#7431 Standard	P40	7431
			#7433 Enterprise	P40	7433
#7435 High Availability			P40	7433	
#2496	#0891	#7440 Capacity BackUp	P40	7440	
Note 6e Model 890	Software group is determined by the combination of processor feature and edition feature. Display the QPRCFEAT system value or DSPHDWRSC TYPE(*AHW) to display the processor feature code value. This value is also shown for the Capacity Card CCIN value when using SST to perform a Capacity Upgrade on Demand.				
	Processor feature	Interactive feature	Software group	Processor feature code or QPRCFEAT value	
	#0197	N/A	P50	0197	
	#0198	N/A	P50	0198	
	#2487	#1576	P50	2AF0	
		#1577	P60	2AF1	
		#1578	P60	2AF2	
		#1579	P60	2AF3	
		#1581	P60	2AF5	
		#1583	P60	2AF7	
		#1585	P60	2AF9	
		#1587	P60	2AFB	
	#2488	#1588	P60	2AFC	
		#1576	P50	2AD0	
		#1577	P60	2AD1	
		#1578	P60	2AD2	
		#1579	P60	2AD3	
#1581		P60	2AD5		
#1583		P60	2AD7		
#1585		P60	2AD9		
#1587		P60	2ADB		
#1588		P60	2ADC		
#1591	P60	2ADF			

Note 6e Model 890 (cont.)	Processor feature	Server feature	Edition feature	Software group	Processor feature code or QPRCFEAT value
	#2497	#0897	#7422 Standard	P50	7422
			#7424 Enterprise	P50	7424
			#7437 High Availability	P50	7424
	#2498	#0898	#7425 Standard	P50	7425
			#7427 Enterprise	P50	7427
			#7438 High Availability	P50	7427
#2499	#0892	#7441 Capacity BackUp	P50	7441	
Note 7	External DASD capacity assumes 70.56 GB LUNs. External DASD cannot exceed maximum system capacity or the maximum number of disk arms.				
Note 8a Model 800	OS/400 V5R2 with the February 2003 level of Licensed Internal Code (LIC) and Cumulative PTF package identified in Information APAR II13365 at: http://www-03.ibm.com/servers/eserver/support/iserries/index.html				
Note 8b Models 810 825 870 890 (#2497 #2498)	OS/400 V5R2 with the February 2003 level of Licensed Internal Code (LIC) and PTFs identified in Information APAR II13551 at: http://www-03.ibm.com/servers/eserver/support/iserries/index.html				
Note 9a	System can run with 256 MB, but the #0864 and #0865 Server features requires a minimum of 512 MB of main storage.				
Note 9b Models 810 825	The Domino Edition servers require a minimum disk and memory capacity as follows.				
	Server feature	Disk	Memory		
	#0769	105 GB	1.5 GB		
	#0770	315 GB	3.5 GB		
	#0771	525 GB	5.5 GB		
	#0772	560 GB	6 GB		
#0773	945 GB	12 GB			
Note 9c	The Server features used for iSeries for Domino specify the minimum amount of disk, memory, and Domino licenses required for an initial order.				
Note 10a	Not supported in the #5094 by the IBM marketing configurator.				

3.7 9406 Model 800 system unit schematic

#2463 and #2464 Processors

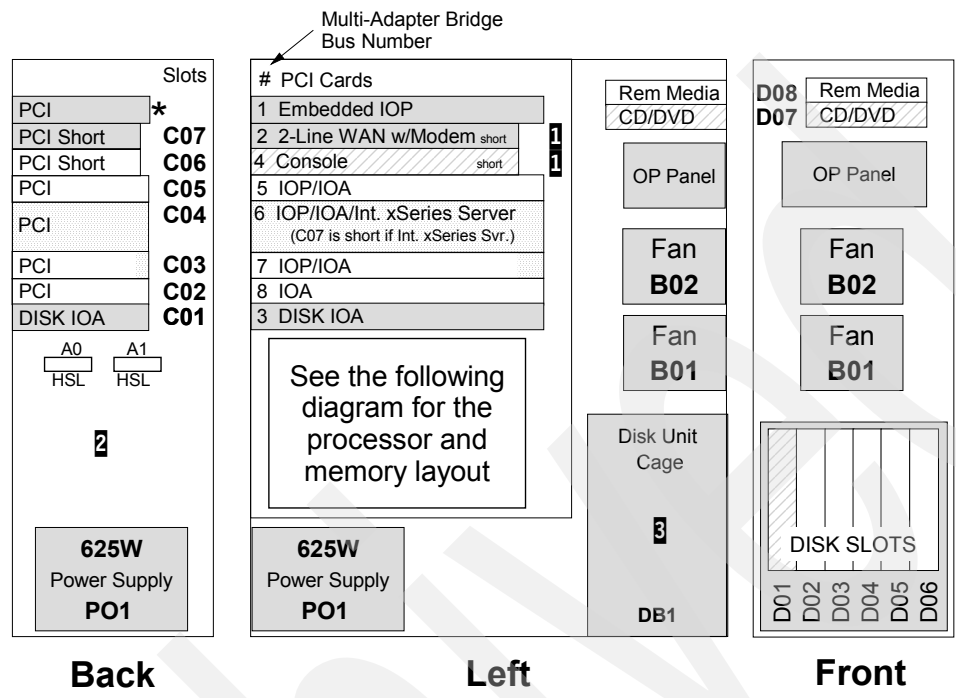

- Note 1:** Cards may be reversed depending on the choice of console.
 - Note 2:** Card slots do not support hot plugging with the #2463 processor.
 - Note 3:** Non-concurrent maintenance cage of the #2463 processor. Concurrent maintenance cage of the #2464 processor.
- * Embedded

Legend

- Base Feature
- Required Feature
- Unavailable if Integrated xSeries Server is installed

Model 800 Processor and Memory

#2463 and #2464

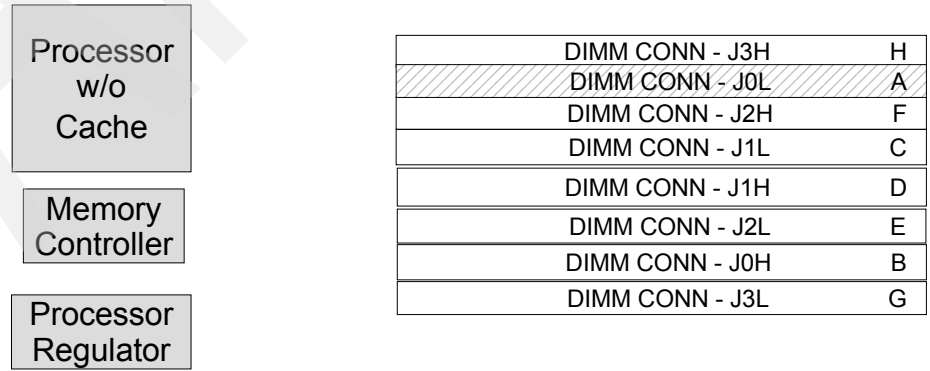

For a schematic of the #7116 System Unit Expansion for the Model 800, refer to 3.9, "iSeries Models 800 and 810 #7116 System Unit Expansion schematic" on page 75.

3.8 9406 Model 810 system unit schematic

#2465, #2466, #2467, and #2469 Processors

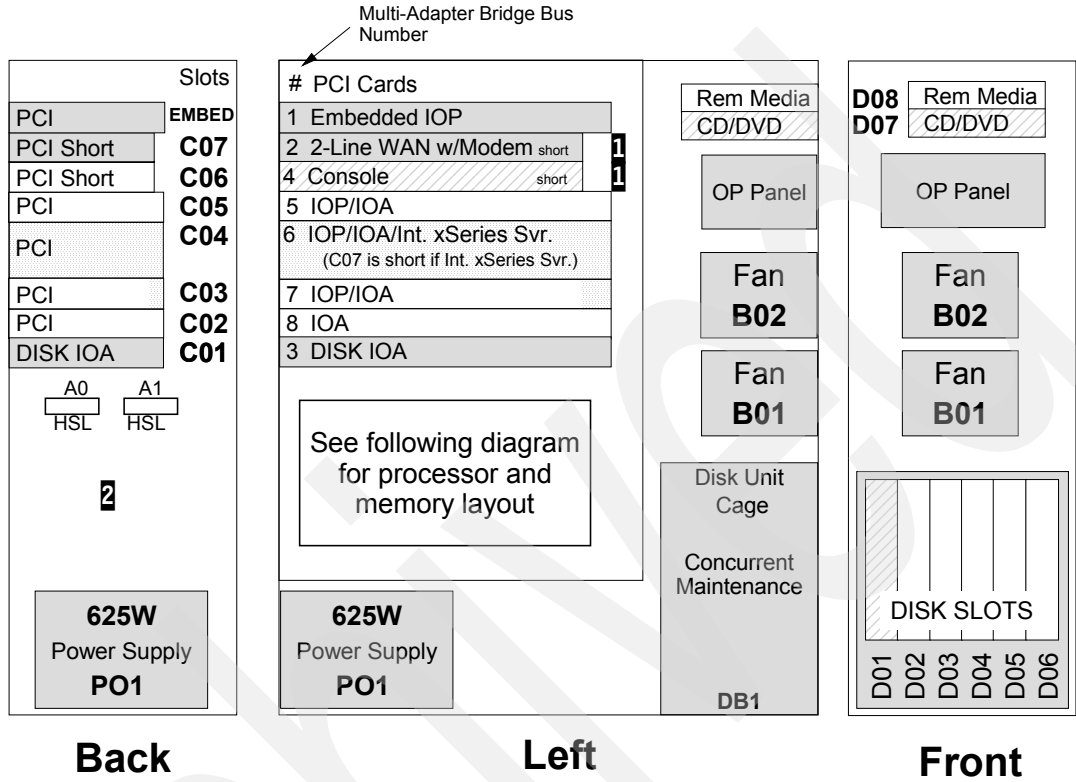

Note 1: Cards may be reversed depending on the choice of console.

Note 2: Card slots do not support hot plugging with the #2466 and #2467 processors.

Legend

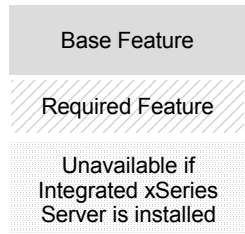

Model 810 Processor and Memory

#2465, #2466, #2467

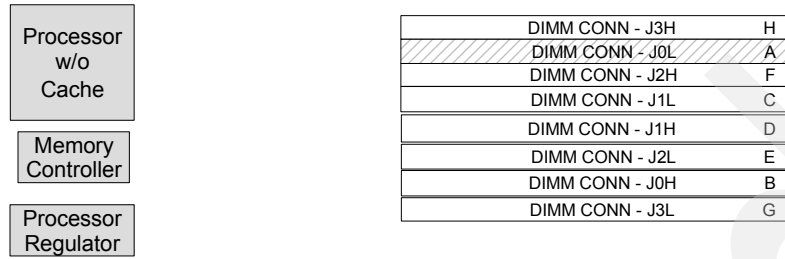

#2469

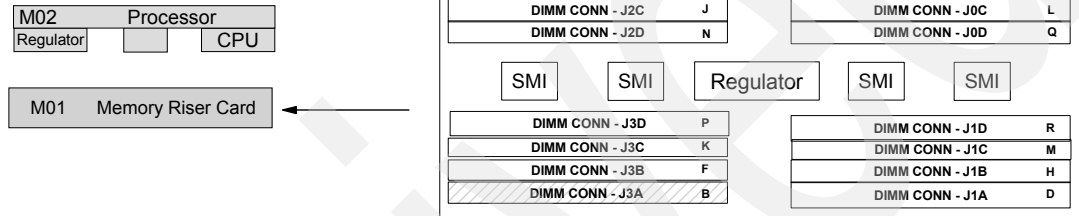

3.9 iSeries Models 800 and 810 #7116 System Unit Expansion schematic

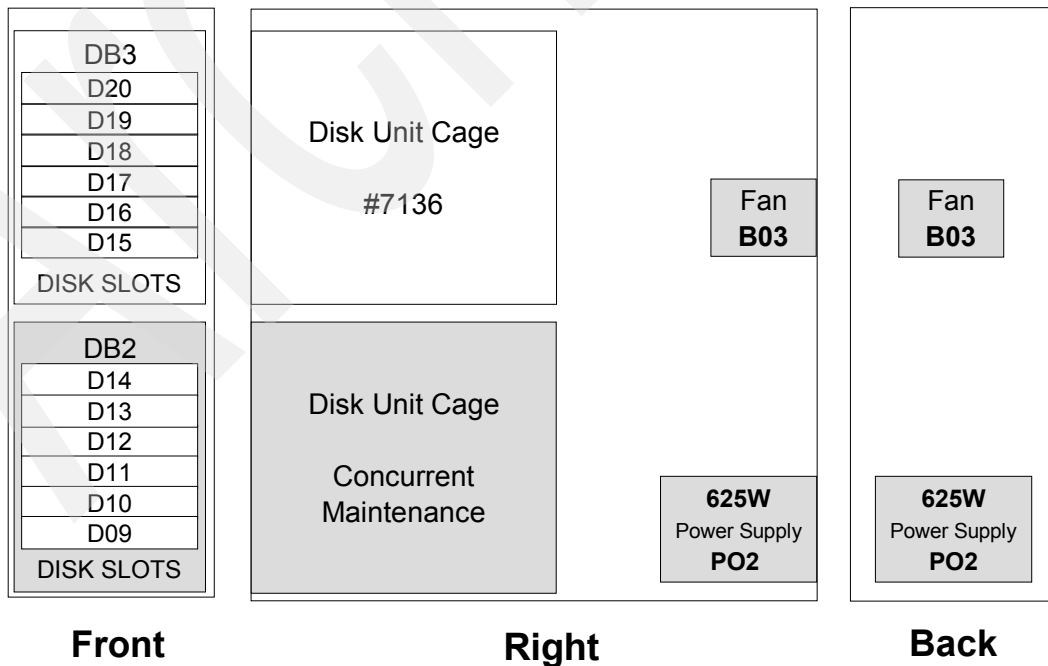

3.10 9406 Model 825 system unit schematic

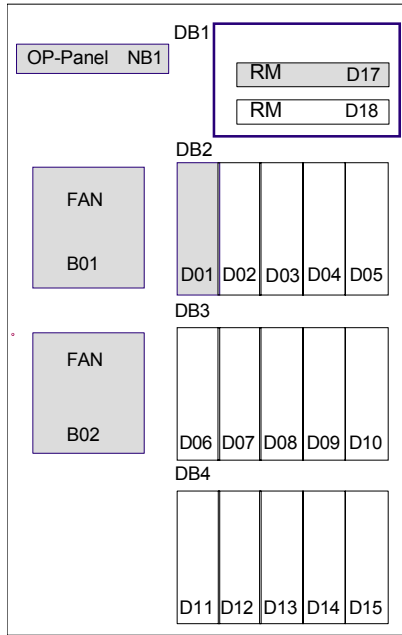

Front

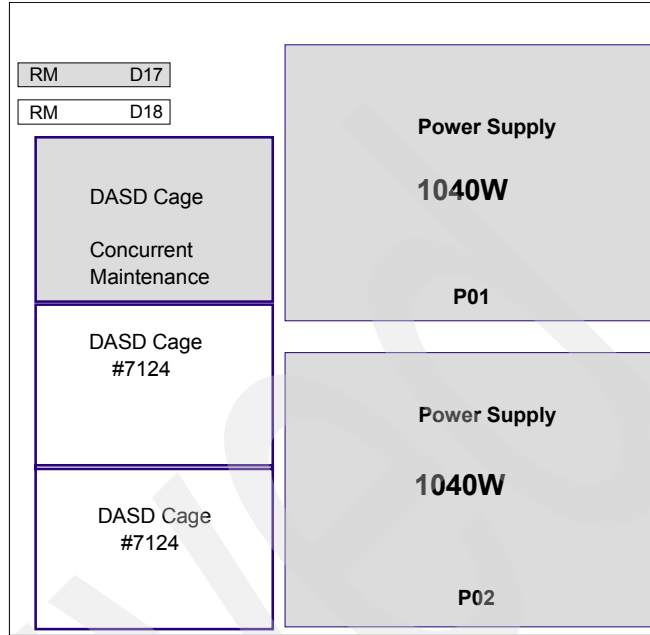

Right

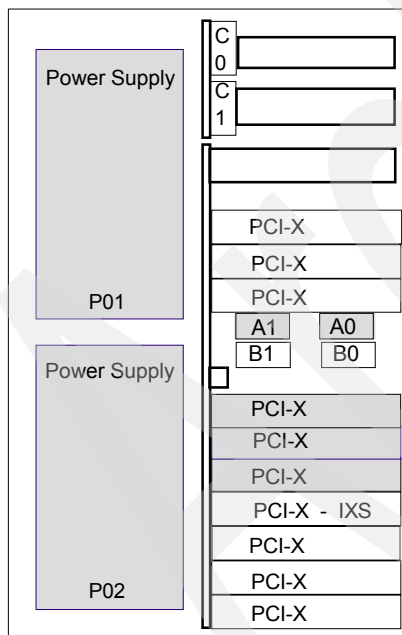

Back

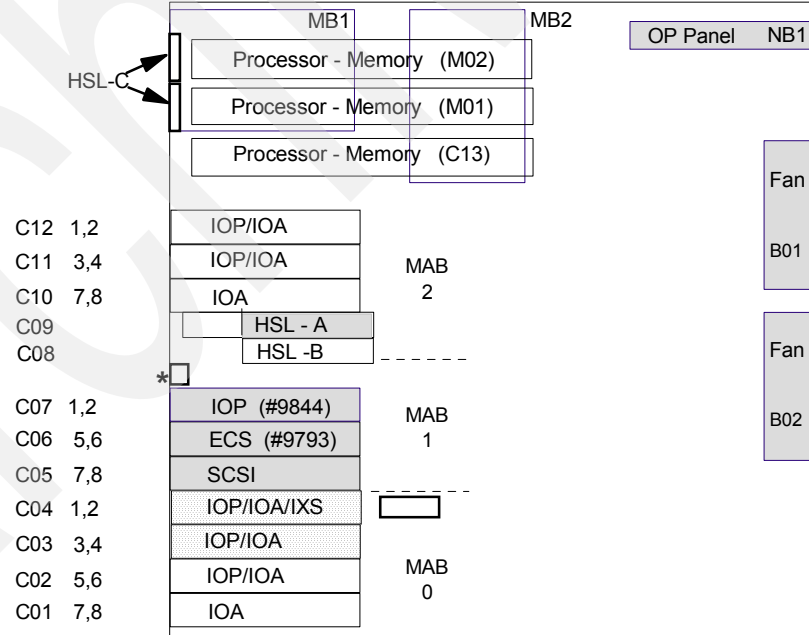

Left

* Embedded Ethernet 10/100 Mbps CCIN 287F Supports LAN Console

Note: Hot plug and concurrent add of the following components are supported:

- ▶ PCI cards
- ▶ Disk units
- ▶ Removable media
- ▶ Power supplies
- ▶ Fans

9406 Model 825 Processor and Memory

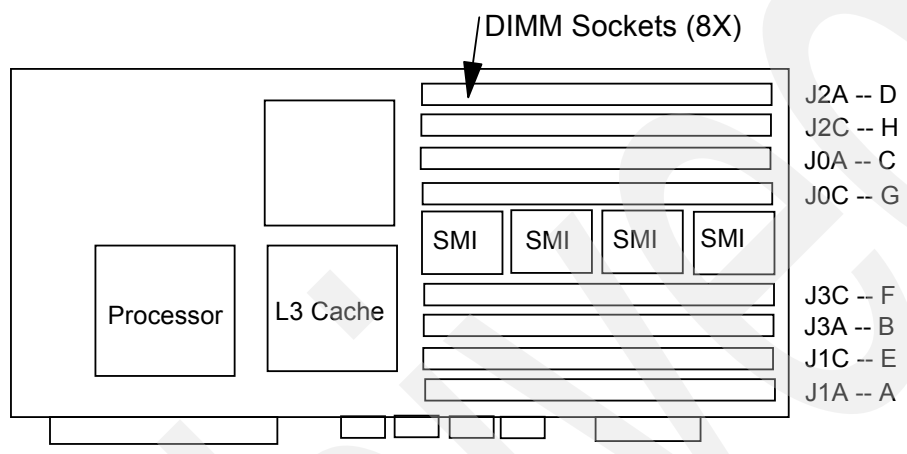

Note: DIMM quad plugging is A, B, C, D and then E, F, G, H

3.11 9406 Model 870 system unit schematic

The following schematic illustrates the Model 870 system unit.

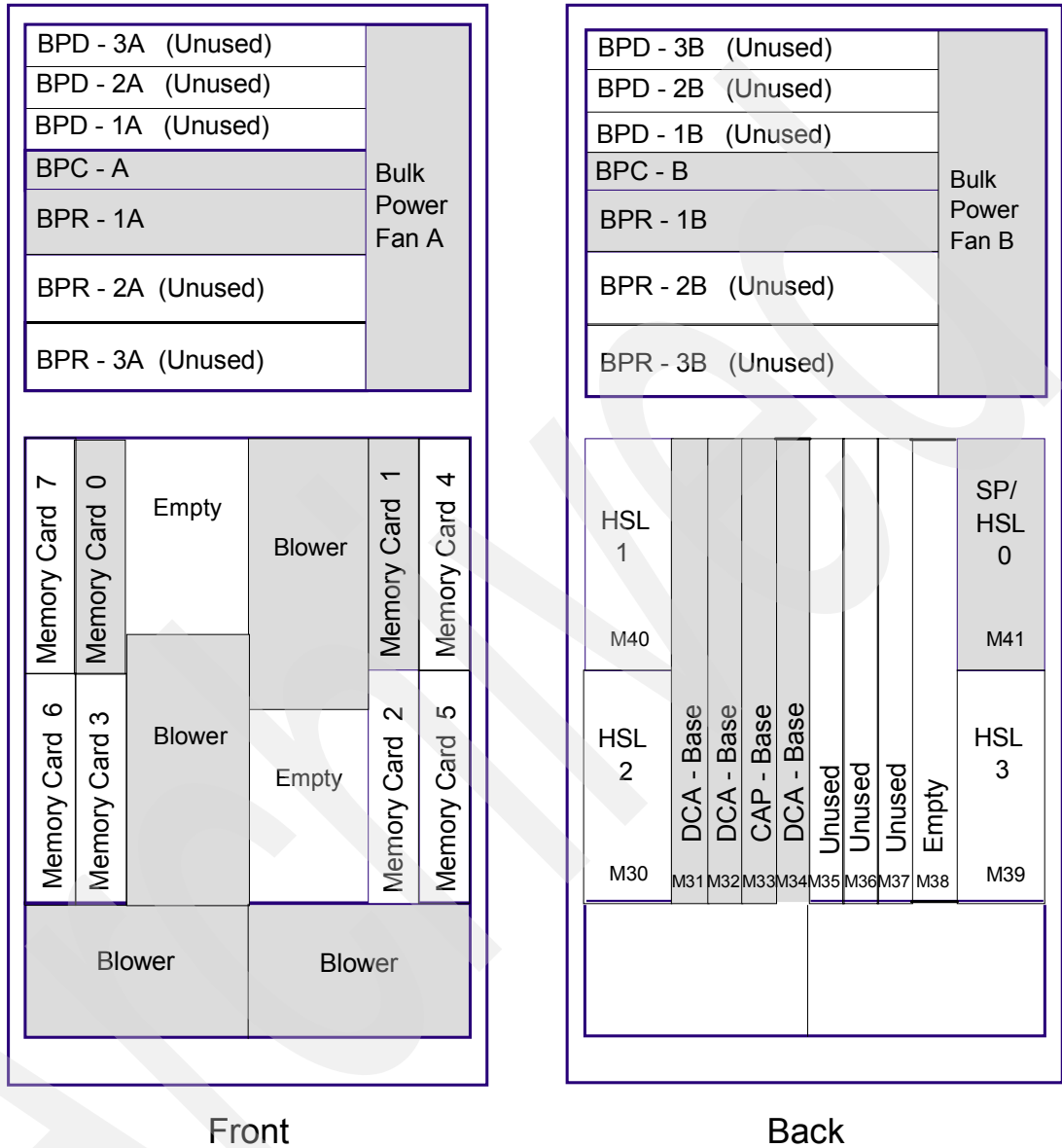

For a schematic of the #9094 Base PCI I/O Enclosure for the Model 870, refer to 3.13, "iSeries Models 870 and 890 #9094 Base PCI I/O Enclosure schematic" on page 85.

The following schematic illustrates the backplane of the Model 870 system unit.

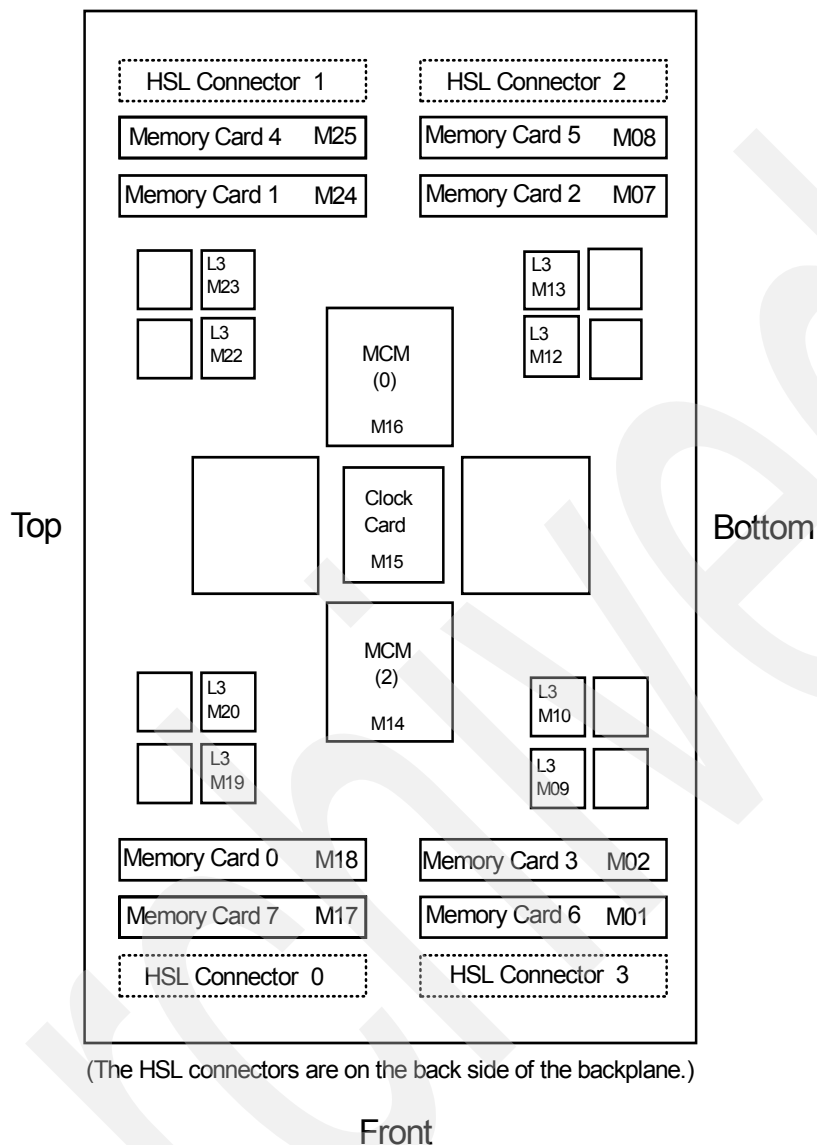

(The HSL connectors are on the back side of the backplane.)

Note: Multichip module (MCM) slots 0 and 2 contain processor modules. MCM slots 1 and 3 have pass-through cards (CCIN 272D) installed.

3.11.1 Model 870 MCM and HSL relationship

The following graphic represents the relationship of high-speed link (HSL) and MCM in a Model 870.

Note: The M40 and M41 are positioned at the rear of the card.

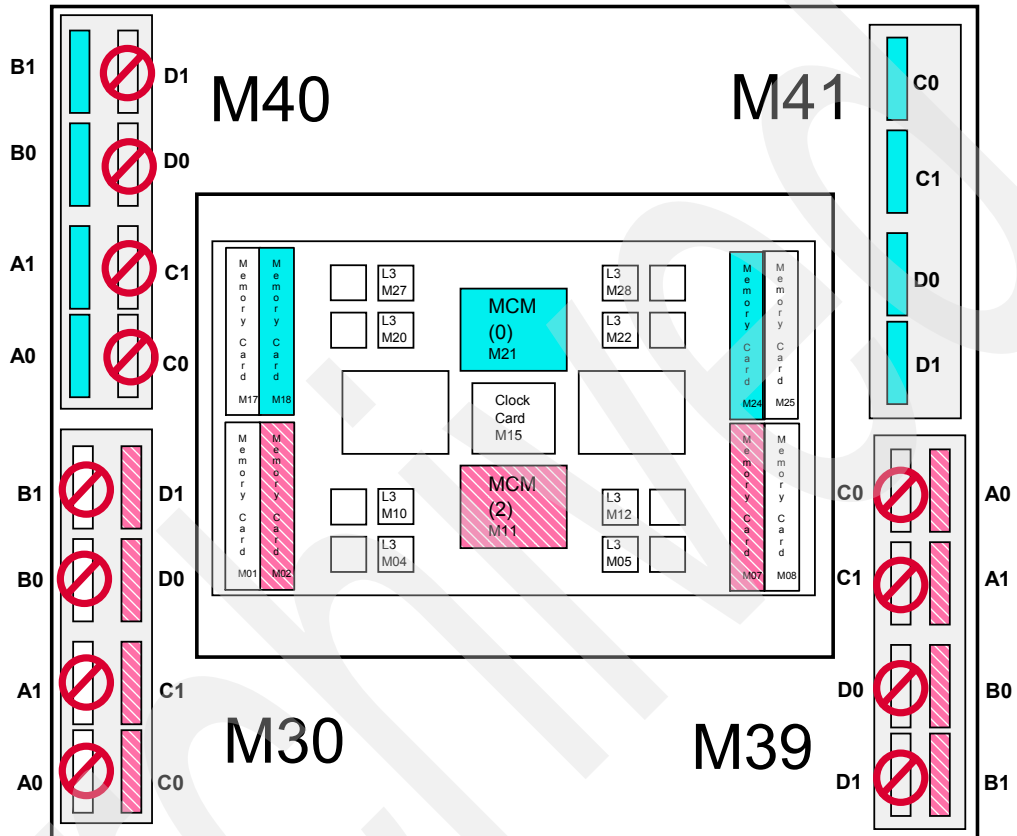

3.12 9406 Model 890 system unit schematic

The following schematic illustrates the Model 890 system unit.

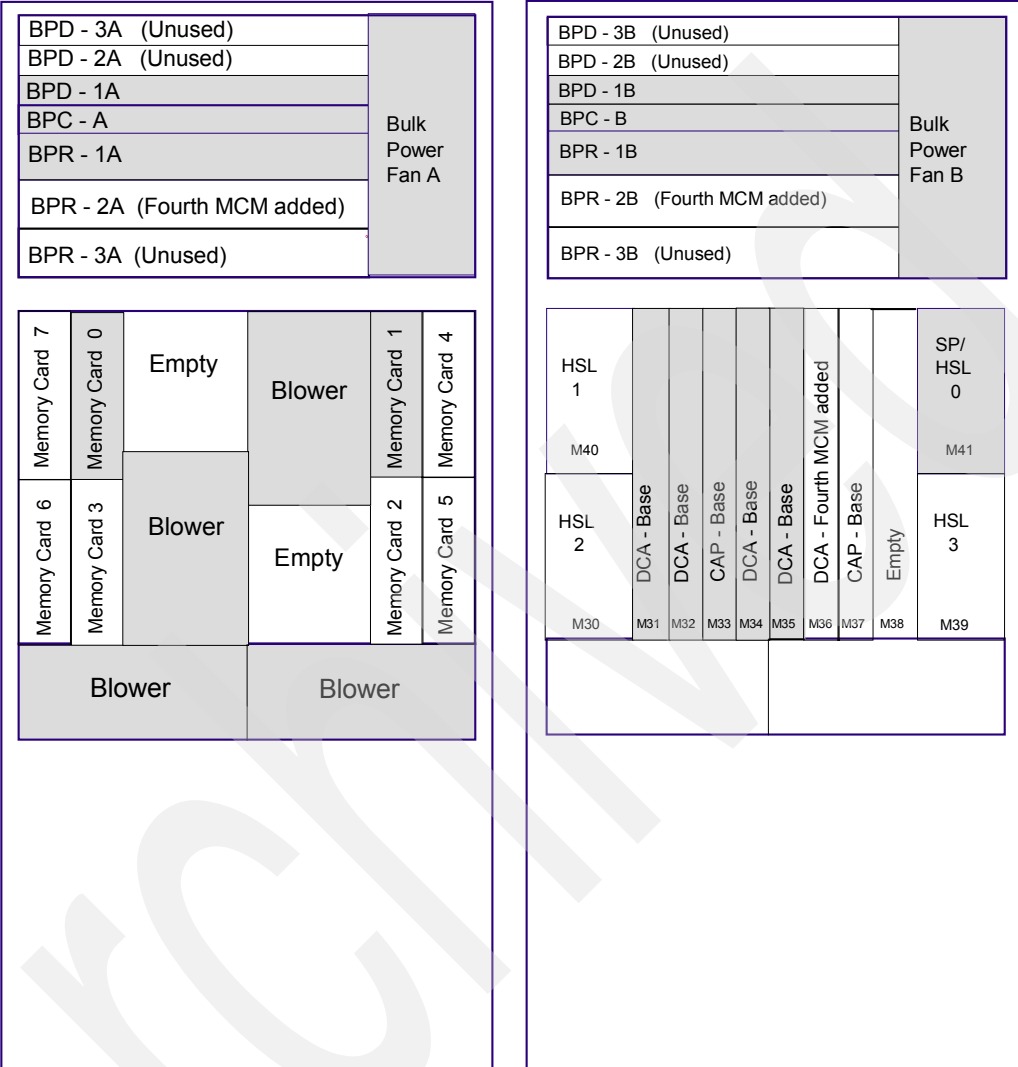

Front

Back

The following schematic illustrates the backplane of the Model 890 system unit.

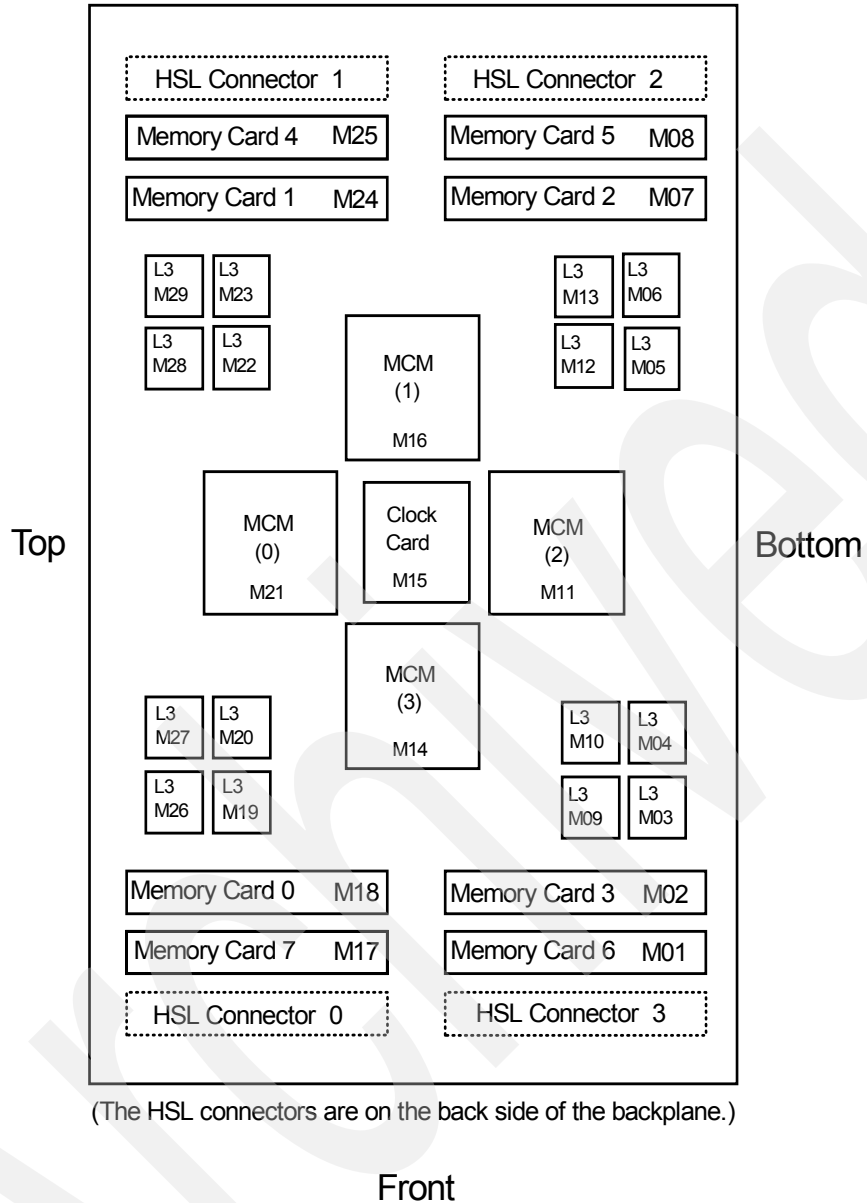

Note: One pass-through card (CCIN 272D) is installed with the 16/24-way processor to fill the empty MCM slot 1.

3.12.1 Model 890 MCM and HSL relationship

The following graphics represent the relationship of HSL and MCM in a Model 890.

Note: The M40 and M41 are positioned at the rear of the card.

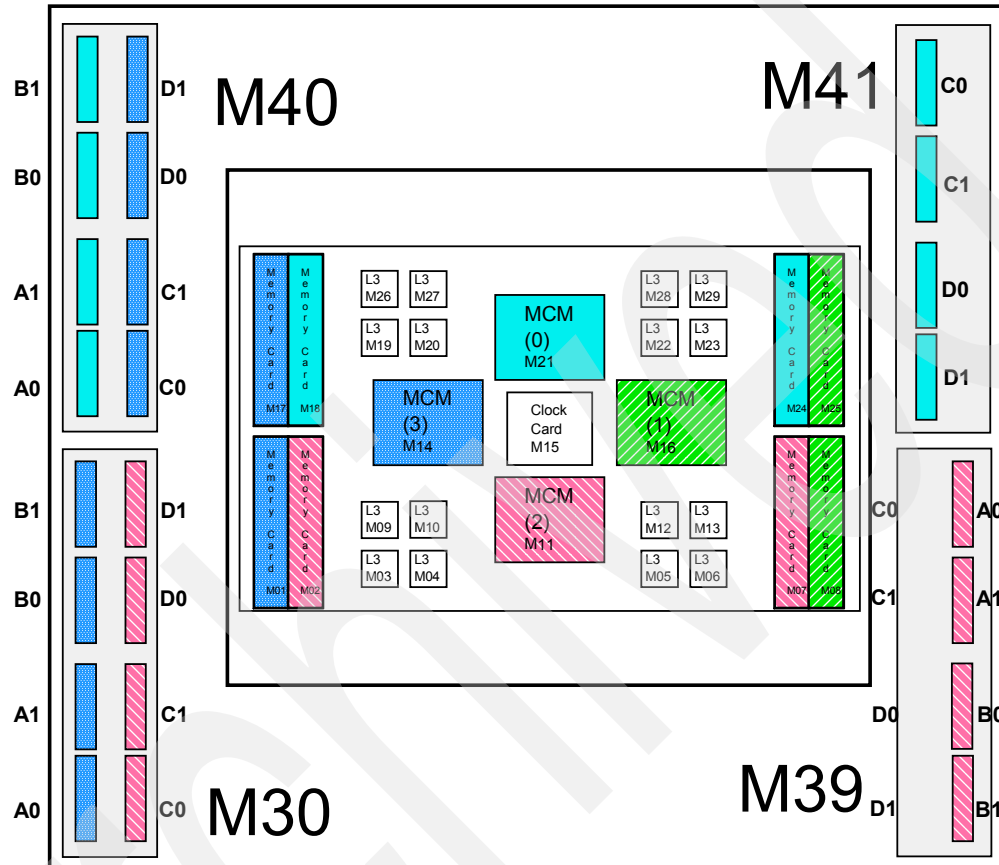

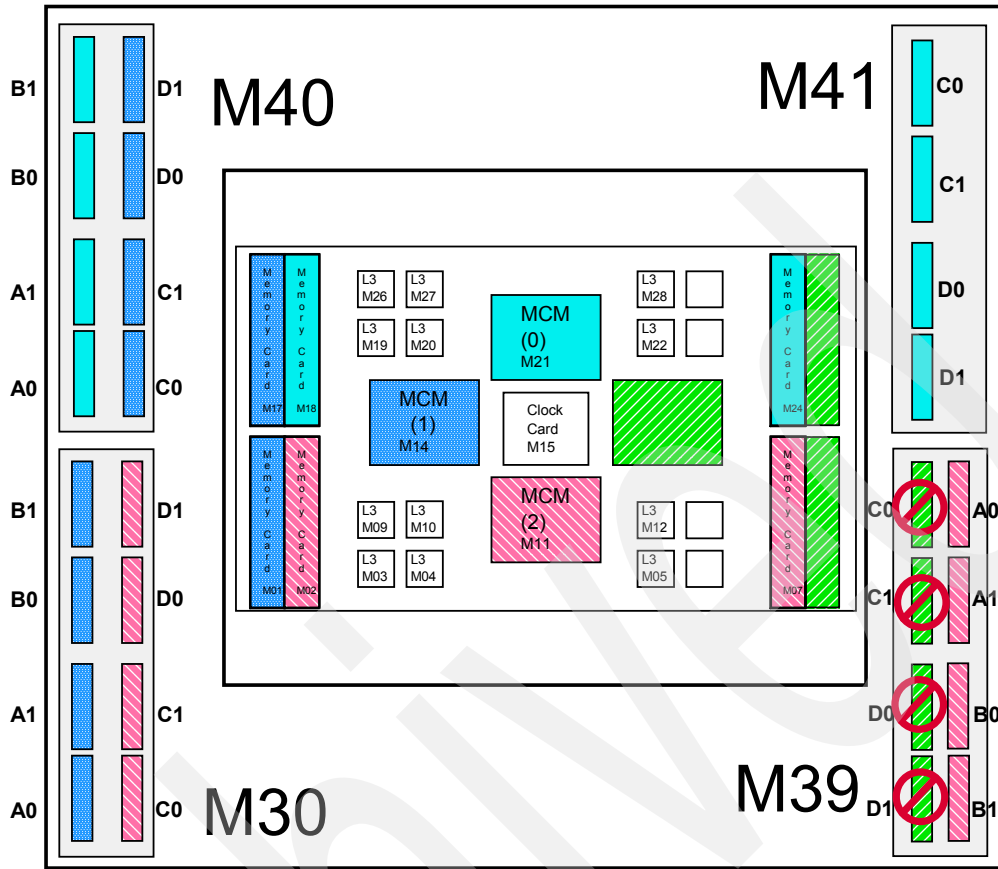

3.13 iSeries Models 870 and 890 #9094 Base PCI I/O Enclosure schematic

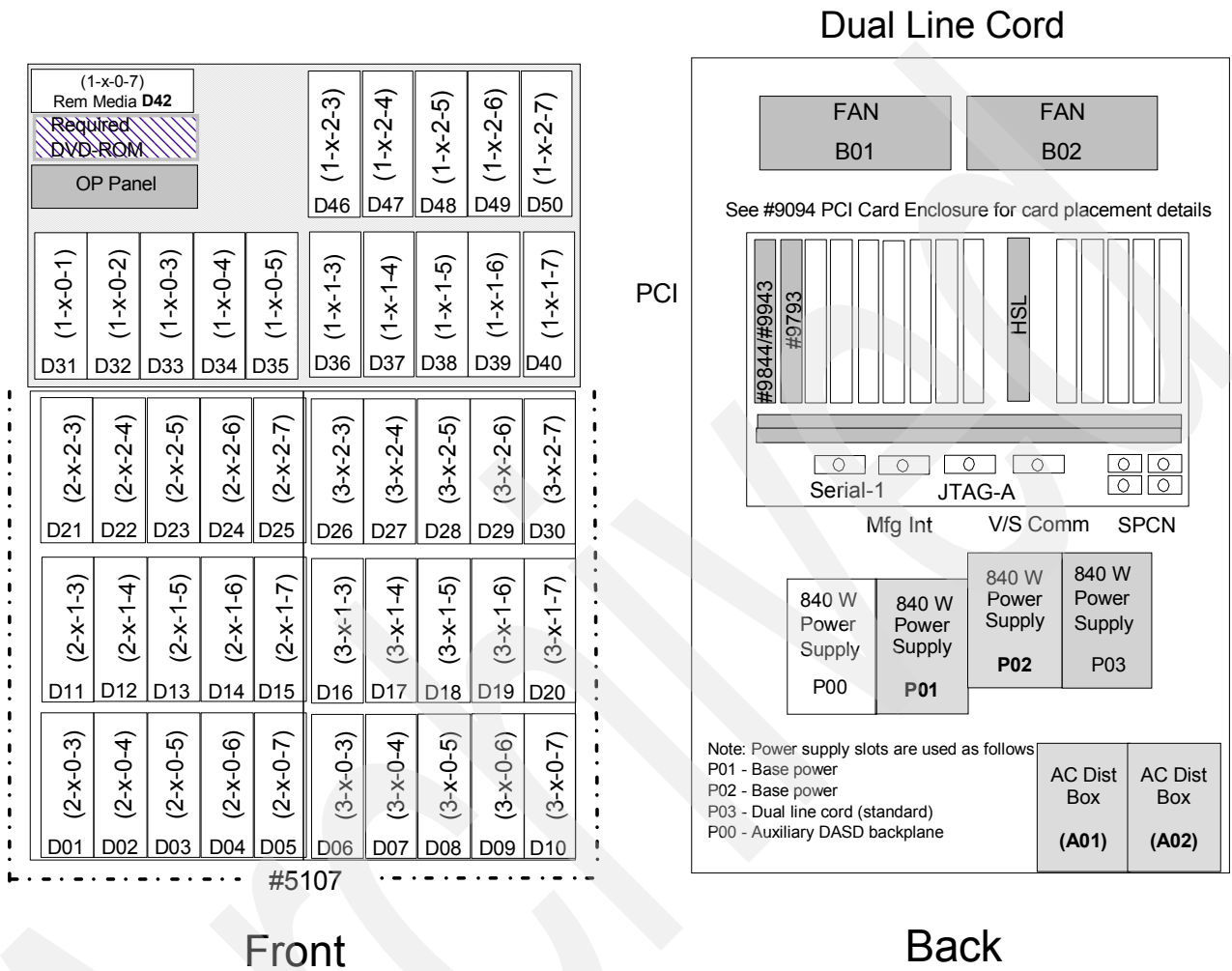

= Base feature
 = Required feature

LEGEND

(W-X-Y-Z)

Kn

W = DS Card Address
X = IOA number
Y = SCSI bus number
Z = AS/400 Drive Address
Kn = Physical Address

Note: Hot plug and concurrent add of PCI cards, disk units, and removable media devices are supported.

3.13.1 #9094 PCI Card Enclosure schematic

Slots	Multi-Adapter Bridge Bus Number	PCI Cards
C01	1,2 #9844 / #9943 ³	Multi-Adapter Bridge Boundary
C02	3,4 #9793	
C03	5,6 IOP/IOA	
C04	7,8 IOA	
C05	1,2 IOP/IXS	Multi-Adapter Bridge Boundary
C06	3 IOA ¹	
C07	4 IOA	
C08	5,6 IOP/IOA	
C09	7,8 IOA	
C10	#9886 / #9887	
C11	1,2 IOP/IXS	Multi-Adapter Bridge Boundary
C12	3 IOA ²	
C13	4 IOA	
C14	5,6 IOP/IOA	
C15	7,8 IOA	

Legend

Base Feature	Required Feature	Unavailable if Integrated xSeries Server is installed
--------------	------------------	---

Note 1: If C05 has an Integrated xSeries Server, slot C06 is unavailable, and slot C07 is available only as a short slot. A #2792 does not reduce a third slot to a short slot.

Note 2: If C11 has an Integrated xSeries Server, slot C12 is unavailable, and slot C13 is available only as a short slot. A #2792 does not reduce a third slot to a short slot.

Note 3: Slot C01 in the #9094 for a Model 870 has a #9844, and a #9844 or #9943 for a Model 890.

3.14 iSeries Models 870 and 890 #8094 Optional 1.8 m I/O Rack schematic

Note: The total number of disk bays is 2 x 45.

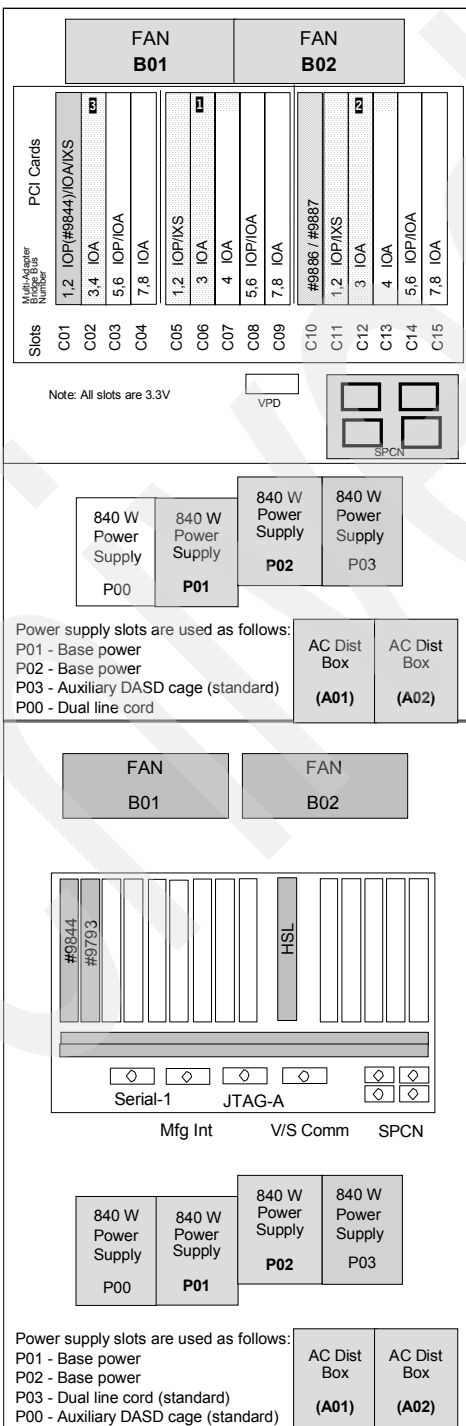
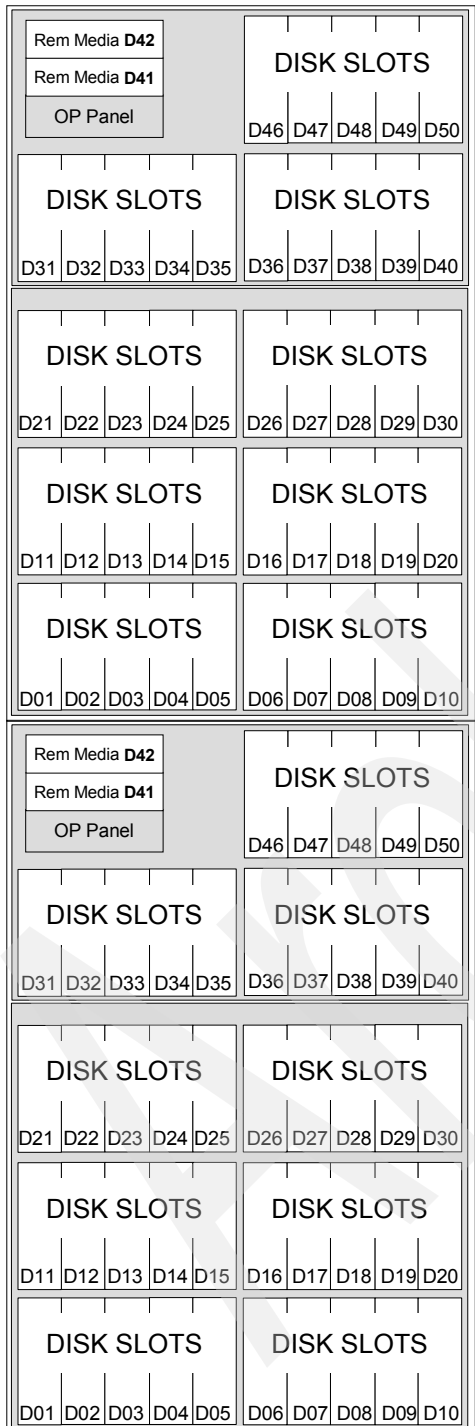

Legend

- Base Feature
- Required Feature
- Unavailable if Integrated Netfinity Server is installed

Note 1: If C05 has an Integrated xSeries Server, slot C06 is unavailable, and slot C07 is available only as a short slot. A #2792 does not reduce a third slot to a short slot.

Note 2: If C11 has an Integrated xSeries Server, slot C12 is unavailable, and slot C13 is available only as a short slot. A #2792 does not reduce a third slot to a short slot.

Note 3: Integrated xSeries Server placement is not supported from the plant. Only a #2792 is allowed in this position.

See the #9094 PCI Card Enclosure for card placement details.

3.15 iSeries Model 800 processors

The iSeries Model 800 initial installation is CSU. Processor upgrades within models are performed by IBM Service Representatives.

Processor feature	Server feature	Edition feature	Model 800 processor
#2463	#0863		300 CPW Uni-Processor in Client/Server Environment <ul style="list-style-type: none"> ▶ SStar 540 MHz Uni (CCIN 25B9) ▶ Includes eight DIMM memory positions (plug directly into the backplane – direct attach) ▶ Includes embedded Base PCI IOP (CCIN 286C) ▶ Includes Common Service Processor (CSP) (CCIN 25B9) <p>The #2463 is withdrawn from marketing as of 01 October 2005.</p>
		#7400	Value Edition Provides 25 CPW for 5250 OLTP (CCIN 7400)
	#0864		300 CPW Uni-Processor in Client/Server Environment <ul style="list-style-type: none"> ▶ SStar 540 MHz Uni (CCIN 25B9) ▶ Includes eight DIMM memory positions (plug directly into the backplane – direct attach) ▶ Includes embedded Base PCI IOP (CCIN 286C) ▶ Includes Common Service Processor (CSP) (CCIN 25B9) <p>The #2463 is withdrawn from marketing as of 01 October 2005.</p>
		#7400	Standard Edition Provides 25 CPW for 5250 OLTP (CCIN 7400) The #2463 is withdrawn from marketing as of 01 October 2005.
#2464	#0865		950 CPW Uni-Processor in Client/Server Environment <ul style="list-style-type: none"> ▶ SStar 540 MHz Uni (CCIN 25B9) ▶ Includes eight DIMM memory positions (plug directly into the backplane – direct attach) ▶ Includes 2 MB L2 cache ▶ Includes embedded Base PCI IOP (CCIN 286C) ▶ Includes Common Service Processor (CSP) (CCIN 25BA) <p>The #2464 is withdrawn from marketing as of 01 June 2006.</p>
		#7408	Advanced Edition Provides 50 CPW for 5250 OLTP (CCIN 7408)

3.16 iSeries Model 810 processors

The iSeries Model 810 initial installation is CSU. Processor upgrades within models are performed by IBM Service Representatives.

Processor feature	Server feature	Edition feature	Model 810 processor
#2465	#0868		750 CPW Uni-Processor in Client/Server Environment <ul style="list-style-type: none"> ▶ SStar 540 MHz Uni (CCIN 25BA) ▶ Includes 2 MB L2 cache ▶ Includes eight DIMM memory positions (plug directly into the backplane – direct attach) ▶ Includes embedded Base IOP (CCIN 286D) ▶ Includes Common Service Processor (CSP) (CCIN 25BA) <p>The #2465 is withdrawn from marketing as of 01 October 2005.</p>
		#7404	Standard Edition Provides limited 5250 OLTP CPW (CCIN 7404)
		#7406	Enterprise Edition Provides up to 750 CPW for 5250 OLTP (CCIN 7406)
		#7445	High Availability Edition Provides up to 750 CPW for 5250 OLTP (CCIN 7406)
#2466	#0866		1020 CPW Uni-Processor in Client/Server Environment <ul style="list-style-type: none"> ▶ SStar 540 MHz Uni (CCIN 25BA) ▶ Includes 2 MB L2 cache ▶ Includes eight DIMM memory positions (plug directly into the backplane – direct attach) ▶ Includes embedded Base IOP (CCIN 286D) ▶ Includes Common Service Processor (CSP) (CCIN 25BA) <p>The #2466 is withdrawn from marketing as of 01 June 2006.</p>
		#7407	Standard Edition Provides limited 5250 OLTP CPW (CCIN 7407)
		#7409	Enterprise Edition Provides up to 1070 CPW for 5250 OLTP (CCIN 7409)
		#7446	High Availability Edition Provides up to 1070 CPW for 5250 OLTP (CCIN 7409)
	#0769	#7407	Domino Edition Provides limited 5250 OLTP CPW (CCIN 7407)
#2467	#0867		1470 CPW Uni-Processor in Client/Server Environment <ul style="list-style-type: none"> ▶ SStar 750 MHz Uni (CCIN 25F0) ▶ Includes 4 MB L2 cache ▶ Includes 16 DIMM memory positions (plug directly into the backplane – direct attach) ▶ Includes embedded Base IOP (CCIN 286E) ▶ Includes Common Service Processor (CSP) (CCIN 25F0) <p>The #2467 is withdrawn from marketing as of 01 June 2006.</p>
		#7410	Standard Edition Provides limited 5250 OLTP CPW (CCIN 7410)
		#7412	Enterprise Edition Provides up to 1470 CPW for 5250 OLTP (CCIN 7412)
		#7447	High Availability Edition Provides up to 1470 CPW for 5250 OLTP (CCIN 7412)
	#0770	#7410	Domino Edition Provides limited 5250 OLTP CPW (CCIN 7410)

Processor feature	Server feature	Edition feature	Model 810 processor
#2469	#0869		2700 CPW 2-way Processor in Client/Server Environment <ul style="list-style-type: none"> ▶ SStar 750 MHz 2-way (CCIN 25EB) ▶ Includes 4 MB L2 cache ▶ Includes sixteen DIMM memory positions via the memory riser card (CCIN 2884) ▶ Includes base I/O backplane (CCIN 282F) ▶ Includes embedded Base IOP (CCIN 284E) ▶ Includes Common Service Processor (CSP) (CCIN 2249) <p>The #2469 is withdrawn from marketing as of 01 June 2006.</p>
		#7428	Standard Edition Provides limited 5250 OLTP CPW (CCIN 7428)
		#7430	Enterprise Edition Provides 2700 CPW for 5250 OLTP (CCIN 7430)
		#7448	High Availability Edition Provides up to 2700 CPW for 5250 OLTP (CCIN 7430)
	#0771	#7428	Domino Edition Provides limited 5250 OLTP CPW (CCIN 7428)

3.17 iSeries Model 825 processors

The iSeries Model 825 initial installation and model upgrades are performed by an IBM Service Representative.

Processor feature	Server feature	Edition feature	Model 825 processor	
#2473	#0873		3600/6600 CPW 3/6-way Processor in Client/Server Environment <ul style="list-style-type: none"> ▶ Includes three POWER4 processor cards (CCIN 25DC) ▶ Includes 96 MB L3 cache (16 MB L3/GP processor) ▶ Includes Smart Chip Processor VPD card (CCIN 2484) ▶ Includes base I/O backplane (CCIN 25CA) ▶ Includes Connector Card (CCIN 289D) ▶ Includes Expansion Card (CCIN 28B3). Provides two RIO-G ports ▶ #1609 processor activation feature. Maximum of three. ▶ #1682 On/Off Capacity on Demand Prepaid feature for Standard Edition* ▶ #1683 On/Off Capacity on Demand Prepaid feature for Enterprise and High Availability Edition* ▶ #1773 On/Off Capacity on Demand enablement feature. <p>* On/Off Capacity on Demand features require PTFs identified in Information APAR II13551 at: http://www-03.ibm.com/servers/eserver/support/series/index.html The #2473 is withdrawn from marketing as of 01 June 2006.</p>	
		#7416	Standard Edition Provides limited 5250 OLTP CPW (CCIN 7416)	
		#7418	Enterprise Edition Provides up to 6600 CPW for 5250 OLTP (CCIN 7418)	
		#7434	High Availability Edition Provides up to 6600 CPW for 5250 OLTP (CCIN 7418)	
		#0772	#7416	Domino Edition Provides limited 5250 OLTP CPW (CCIN 7416)
		#0773	#7416	Domino Edition Provides limited 5250 OLTP CPW (CCIN 7416)
#2495	#0890		1250/6600 CPW 1/6-way Processor in Client/Server Environment <ul style="list-style-type: none"> ▶ Includes three POWER4 processor cards (CCIN 25DC) ▶ Includes 96 MB L3 cache (16 MB L3/GP processor) ▶ Includes Smart Chip Processor VPD card (CCIN 2484) ▶ Includes base I/O backplane (CCIN 25CA) ▶ Includes Connector Card (CCIN 289D) ▶ Includes Expansion Card (CCIN 28B3). Provides two RIO-G ports ▶ #1779 On/Off Capacity on Demand enablement feature* <p>* On/Off Capacity on Demand features require PTFs identified in Information APAR II13551 at: http://www-03.ibm.com/servers/eserver/support/series/index.html</p>	
		#7439	Capacity BackUp Edition Provides up to 6600 CPW for 5250 OLTP (CCIN 7439) for Capacity BackUp Edition <ul style="list-style-type: none"> ▶ #1697 On/Off Capacity on Demand Prepaid feature * ▶ #1797 TCoD Billing feature 	

3.18 iSeries Model 870 processors

The iSeries Model 870 initial installation and model upgrades are performed by an IBM Service Representative.

Processor feature	Server feature	Edition feature	Model 870 processor
#2486	#0886		<p>115000 - 20000 CPW 8/16-way Processor in Client/Server Environment</p> <ul style="list-style-type: none"> ▶ Processor Capacity Card (CCIN 7419 or CCIN 7421) ▶ Processor 0 (CCIN 25D3) ▶ Processor 1 (CCIN 25D3) ▶ #1611 Capacity Upgrade on Demand activation code (up to eight on the #2486) ▶ #1685 On/Off Capacity on Demand Prepaid feature for Standard Edition* ▶ #1686 On/Off Capacity on Demand Prepaid feature for Enterprise and High Availability Editions* ▶ #1776 On/Off Capacity on Demand enablement feature <p>* On/Off Capacity on Demand features require PTFs identified in Information APAR II13551 at: http://www-03.ibm.com/servers/eserver/support/series/index.html</p> <p>The #2486 is withdrawn from marketing as of 01 June 2006.</p>
		#7419	<p>Standard Edition Provides limited 5250 OLTP CPW (CCIN 7419)</p>
		#7421	<p>Enterprise Edition Provides up to 20000 CPW for 5250 OLTP (CCIN 7421)</p>
		#7436	<p>High Availability Edition Provides up to 20000 CPW for 5250 OLTP (CCIN 7421)</p>
#2489	#0889		<p>7700 - 11500 CPW 5/8-way Processor in Client/Server Environment</p> <ul style="list-style-type: none"> ▶ Processor Capacity Card (CCIN 7431 or CCIN 7433) ▶ Processor 0 (CCIN 25D3) ▶ #1614 Capacity Upgrade on Demand activation code (up to three on the #2489) ▶ #1684 On/Off Capacity on Demand Prepaid feature for Standard Edition* ▶ #1695 On/Off Capacity on Demand Prepaid feature for Enterprise and High Availability Editions* ▶ #1774 On/Off Capacity on Demand enablement feature * <p>* On/Off Capacity on Demand features require PTFs identified in Information APAR II13551 at: http://www-03.ibm.com/servers/eserver/support/series/index.html</p> <p>The #2489 is withdrawn from marketing as of 01 June 2006.</p>
		#7431	<p>Standard Edition Provides limited 5250 OLTP CPW (CCIN 7431)</p>
		#7433	<p>Enterprise Edition Provides up to 11500 CPW for 5250 OLTP (CCIN 7433)</p>
		#7435	<p>High Availability Edition Provides up to 11500 CPW for 5250 OLTP (CCIN 7433)</p>
#2496	#0891		<p>3200 - 20000 CPW 2/16-way Processor in Client/Server Environment</p> <ul style="list-style-type: none"> ▶ Processor Capacity Card (CCIN 7440) ▶ Processor 0 (CCIN 25D3) ▶ Processor 1 (CCIN 25D3) ▶ #166x On/Off Capacity on Demand Prepaid feature ▶ #1780 On/Off Capacity on Demand enablement feature * <p>* On/Off Capacity on Demand features require PTFs identified in Information APAR II13551 at: http://www-03.ibm.com/servers/eserver/support/series/index.html</p>
		#7440	<p>Capacity BackUp Edition Provides up to 11800 CPW for 5250 OLTP (CCIN 7440) for the Capacity BackUp Edition</p> <ul style="list-style-type: none"> ▶ #1698 On/Off Capacity on Demand Prepaid feature* ▶ #1798 TCoD Billing feature <p>* On/Off Capacity on Demand features require PTFs identified in Information APAR II13551 at: http://www-03.ibm.com/servers/eserver/support/series/index.html</p>

3.19 iSeries Model 890 processors

The iSeries Model 890 initial installation and model upgrades are performed by an IBM Service Representative.

Processor	Server feature	Model 890 processor
#0197	5250 Interactive features	29300 CPW 24-way Processor in Client/Server Environment <ul style="list-style-type: none"> ▶ Processor Capacity Card (CCIN 0197) ▶ Processor 0 (CCIN 25D3) ▶ Processor 1 (CCIN 25D3) ▶ Processor 2 (CCIN 25D3) The #0197 is represented by Processor Feature Code 0197.
#0198	5250 Interactive features	37400 CPW 32-way Processor in Client/Server Environment <ul style="list-style-type: none"> ▶ Processor Capacity Card (CCIN 0198) ▶ Processor 0 (CCIN 25D5) ▶ Processor 1 (CCIN 25D5) ▶ Processor 2 (CCIN 25D5) ▶ Processor 3 (CCIN 25D5) The #0198 is represented by Processor Feature Code 0198.
#2487		20000 - 29300 CPW 16/24-way Processor in Client/Server Environment <ul style="list-style-type: none"> ▶ Processor Capacity Card (CCIN 2487) ▶ Processor 0 (CCIN 25D5) ▶ Processor 1 (CCIN 25D5) ▶ Processor 2 (CCIN 25D5) ▶ #1610 CUoD activation code* (up to eight on the #2487) ▶ #166x On/Off Capacity on Demand Prepaid feature <p>* On/Off Capacity on Demand features require PTFs identified in Information APAR II13551 at: http://www-03.ibm.com/servers/eserver/support/series/index.html</p>
	#1576	Optional 120 CPW in 5250 Interactive Environment The #2487-#1576 is represented by Processor Feature Code 2AF0.
	#1577	Optional 240 CPW in 5250 Interactive Environment The #2487-#1577 is represented by Processor Feature Code 2AF1.
	#1578	Optional 560 CPW in 5250 Interactive Environment The #2487-#1578 is represented by Processor Feature Code 2AF2.
	#1579	Optional 1050 CPW in 5250 Interactive Environment The #1579-#1579 is represented by Processor Feature Code 2AF3.
	#1581	Optional 2000 CPW in 5250 Interactive Environment The #2487-#1581 is represented by Processor Feature Code 2AF5.
	#1583	Optional 4550 CPW in 5250 Interactive Environment The #2487-#1583 is represented by Processor Feature Code 2AF7.
	#1585	Optional 10000 CPW in 5250 Interactive Environment The #2487-#1585 is represented by Processor Feature Code 2AF9.
	#1587	Optional 16500 CPW in 5250 Interactive Environment The #2487-#1587 is represented by Processor Feature Code 2AFB.
	#1588	Optional 20200 CPW in 5250 Interactive Environment The #2487-#1588 is represented by Processor Feature Code 2AFC.

Processor	Server feature	Model 890 processor
#2488		29300 - 37400 CPW 24/32-way Processor in Client/Server Environment <ul style="list-style-type: none"> ▶ Processor Capacity Card (CCIN 2488) ▶ Processor 0 (CCIN 25D3) ▶ Processor 1 (CCIN 25D3) ▶ Processor 2 (CCIN 25D3) ▶ Processor 3 (CCIN 25D3) ▶ #1610 CUoD activation code* (up to eight on the #2488) ▶ #166x On/Off Capacity on Demand Prepaid feature * On/Off Capacity on Demand features require PTFs identified in Information APAR II13551 at: http://www-03.ibm.com/servers/eserver/support/iserries/index.html
	#1576	Optional 120 CPW in 5250 Interactive Environment The #2488-#1576 is represented by Processor Feature Code 2AD0.
	#1577	Optional 240 CPW in 5250 Interactive Environment The #2488-#1577 is represented by Processor Feature Code 2AD1.
	#1578	Optional 560 CPW in 5250 Interactive Environment The #2488-#1578 is represented by Processor Feature Code 2AD2.
	#1579	Optional 1050 CPW in 5250 Interactive Environment The #2488-#1579 is represented by Processor Feature Code 2AD3.
	#1581	Optional 2000 CPW in 5250 Interactive Environment The #2488-#1581 is represented by Processor Feature Code 2AD5.
	#1583	Optional 4550 CPW in 5250 Interactive Environment The #2488-#1583 is represented by Processor Feature Code 2AD7.
	#1585	Optional 10000 CPW in 5250 Interactive Environment The #2488-#1585 is represented by Processor Feature Code 2AD9.
	#1587	Optional 16500 CPW in 5250 Interactive Environment The #2488-#1587 is represented by Processor Feature Code 2ADB.
	#1588	Optional 20200 CPW in 5250 Interactive Environment The #2488-#1588 is represented by Processor Feature Code 2ADC.
	#1591	Optional 37400 CPW in 5250 Interactive Environment The #2488-#1591 is represented by Processor Feature Code 2ADF.

Processor feature	Server feature	Edition feature	Model 890 processor
#2497	#0897		20000 - 29300 CPW 16/24-way Processor in Client/Server Environment <ul style="list-style-type: none"> ▶ Processor Capacity Card (CCIN 7422 or 7424) ▶ Processor 0 (CCIN 25D3) ▶ Processor 1 (CCIN 25D3) ▶ Processor 2 (CCIN 25D3) ▶ #1612 Capacity Upgrade on Demand Activation code (up to eight on the #2497) ▶ #1688 On/Off Capacity on Demand Prepaid feature for Standard Edition* ▶ #1689 On/Off Capacity on Demand Prepaid feature for Enterprise and High Availability Edition* ▶ #1777 On/Off Capacity on Demand enablement feature * * On/Off Capacity on Demand features require PTFs identified in Information APAR II13551 at: http://www-03.ibm.com/servers/eserver/support/iserries/index.html The #2497 is withdrawn from marketing as of 01 June 2006.
		#7422	Standard Edition Provides limited 5250 OLTP CPW (CCIN 7422).
		#7424	Enterprise Edition Provides up to 29300 CPW for 5250 OLTP (CCIN 7424).
		#7437	High Availability Edition Provides up to 29300 CPW for 5250 OLTP (CCIN 7424).

Processor feature	Server feature	Edition feature	Model 890 processor
#2498	#0898		29300 - 37400 CPW 24/32-way Processor in Client/Server Environment <ul style="list-style-type: none"> ▶ Processor Capacity Card (CCIN 2425 or 7427) ▶ Processor 0 (CCIN 25D3) ▶ Processor 1 (CCIN 25D3) ▶ Processor 2 (CCIN 25D3) ▶ Processor 3 (CCIN 25D3) ▶ #1613 Capacity Upgrade on Demand Activation code (up to eight on the #2498) ▶ #1691 On/Off Capacity on Demand Prepaid feature for Standard Edition* ▶ #1692 On/Off Capacity on Demand Prepaid feature for Enterprise and High Availability Edition* ▶ #1778 On/Off Capacity on Demand enablement feature <p>* On/Off Capacity on Demand features require PTFs identified in Information APAR I113551 at: http://www-03.ibm.com/servers/eserver/support/series/index.html The #2498 is withdrawn from marketing as of 01 June 2006.</p>
		#7425	Standard Edition Provides limited 5250 OLTP CPW for Standard Edition (CCIN 7425).
		#7427	Enterprise Edition Provides up to 37400 CPW for 5250 OLTP (CCIN 7427).
		#7438	High Availability Edition <ul style="list-style-type: none"> ▶ Processor Capacity Card (CCIN 7427) ▶ #1699 On/Off Capacity on Demand Prepaid feature* ▶ #1799 TCoD Billing feature
#2499	#0892		5600 - 37400 CPW 4/32-way Processor in Client/Server Environment <ul style="list-style-type: none"> ▶ #1781 On/Off Capacity on Demand enablement feature * ▶ #166x On/Off Capacity on Demand Prepaid feature <p>* On/Off Capacity on Demand features require PTFs identified in Information APAR I113551 at: http://www-03.ibm.com/servers/eserver/support/series/index.html</p>
		#7441	Capacity BackUp Edition Provides up to 37400 CPW for 5250 OLTP (CCIN 2488)

3.20 iSeries Models 800, 810, 825, 870, and 890 features

You can find feature descriptions, including details about power and packaging and main memory, in Chapter 4, “IBM System i5, eServer i5, and iSeries features and placement” on page 97.

3.21 Supported upgrades for Models 800, 810, 825, 870, and 890

Refer to 1.1, “Upgrades for System i processors” on page 2 for an overview of the upgrades supported for iSeries models.

Archived

IBM System i5, eServer i5, and iSeries features and placement

This chapter describes supported features for the IBM System i5, IBM eServer i5, and iSeries 800, 810, 825, 870, and 890 system units and towers, such as the power and packaging, main storage, workstation controller and console features, and communications features. This includes local area networks (LANs) and wide area networks (WANs), disk units, internal tape units, CD-ROM, DVD-RAM, DVD-ROM, and magnetic media controllers. Processor features are described in Chapter 2, "IBM System i5 and eServer i5 models" on page 5 and Chapter 3, "iSeries 800, 810, 825, 870, and 890 models" on page 59.

Note 1: Some of the feature descriptions in this chapter do not specifically state if the feature is supported in a specific server. For example, some feature codes might be supported in the IBM System i5 Model 520+, 550+, 570+, 595, but not in the eServer i5 Model 520, 550, 570, or 595, or even in the iSeries 800, 810, 825, 870, and 890 servers. Refer to the product announcement letter or check with your IBM representative if you require this information.

Note 2: The darker shaded areas in the following tables and graphics indicate the base features.

Note 3: Some of the feature descriptions in this chapter do not fully identify the required minimum operating system level. For example, a feature which is supported with i5/OS V5R4 might need additional PTFs when installed in an i5/OS V5R3 or OS/400 V5R2 system. Some features require a different LIC level.

To see the PTF prerequisites for a specific feature code, click the feature code button in the search results of the hardware tab of the IBM eServer™ Prerequisite tool at:

http://www-912.ibm.com/e_dir/eServerPrereq.nsf

Note 4: The HSL, SPCN, and dual line cord feature codes and descriptions can be found in Chapter 11, "HSL, SPCN, line cord, and communication cables for IBM System i5, eServer i5, and iSeries systems" on page 377.

4.1 PCI card placement for IBM System i5, eServer i5 and iSeries servers

The implementation of Peripheral Component Interconnect (PCI) architecture in iSeries servers provides flexibility in the placement of input/output processors (IOPs) and input/output adapters (IOAs). This can result in a more efficient use of card slots, which in turn can lower the cost of implementation. For example, a specific PCI IOP can support two high-performance IOAs, or four slower IOAs. However, it might not have the capacity to support one high-performance IOA and two slower IOAs.

PCI architecture changes the configuration rules associated with card placement in IBM System i5 and eServer i5 Models 520, 550, 570, and 595, and iSeries Models 800, 810, 825, 870, and 890 servers. PCI cards are subject to plugging rules. Earlier models require IOPs to be in specific slots in the system and expansion towers. Increased configuration flexibility reinforces a requirement to understand the detailed configuration rules.

Important: If the configuration rules and restrictions are not fully understood and followed, it is possible to create a hardware configuration that does not work, marginally works, or quits working when a system is upgraded to future software releases.

The IBM Redpapers *PCI and PCI-X Placement Rules for IBM System i5, eServer i5, and iSeries servers with i5/OS V5R4 and V5R3*, REDP-4011, and *PCI Card Placement Rules for the IBM @server iSeries Server OS/400 Version 5 Release 2: September 2003*, REDP-3638 for OS/400 V5R2 and earlier releases, describe the configuration and card placement rules that you must understand and follow to develop valid configurations. Use these Redpapers as a guide when configuring IOAs and IOPs to size the system to meet client expectations.

Features offered without the requirement of an IOP are listed in Table 4-2 on page 186.

4.2 Power and packaging

Power and packaging	
#0006	<p>#0006 LPAR Restrict Build Process</p> <p>The #0006 is added to an initial order where LPAR #0140 is requested. This #0006 instructs manufacturing to only load SLIC on the minimum number of disk drives.</p> <p>The #0006 is mutually exclusive with #5000 SW Preload and with #0205 RISC-to-RISC migration.</p> <p>Supported on Models 520, 550, 570, 595, 800, 810, 820, 825, 830, 840, 870, 890, and 9411-100.</p>
#0092	<p>#0092 External xSeries Attach Specify</p> <p>The #0092 is used to specify the number of external xSeries servers connected to the system. The IBM marketing configurator uses this specify code to determine the number of high-speed link (HSL) and System Power Control Network (SPCN) cables required and to ensure that the number of external xSeries servers does not exceed the system limit. Each external xSeries server is cabled with HSL cables and attached to the SPCN string like all other HSL attached I/O towers.</p> <p>A 1519-100 Integrated xSeries Adapter for iSeries or 1519-200 Integrated xSeries Adapter for i5 model is required in each external xSeries server attached.</p> <p>Minimum operating system level: OS/400 V5R1 for 1519-100 Integrated xSeries Adapter for iSeries and i5/OS V5R3 for 1519-200 Integrated xSeries Adapter</p> <p>Supported on Models 520, 550, 570, 595, 800, 810, 820, 825, 830, 840, 870, and 890.</p>

#0123	<p>#0123 - #5074 Lower Unit in Rack</p> <p>The #0123 feature specifies that one #5074 PCI Expansion Tower is to be mounted in the bottom of a #0551 iSeries Rack. The #0123 can be specified on initial orders and on Miscellaneous Equipment Specification (MES) orders, however support for the field merging a #5074 into a #0551 iSeries Rack is not offered (due to the weight of the #5074). A line cord for the #5074 must be ordered with the #5074.</p> <p>Corequisites:</p> <ul style="list-style-type: none"> ▶ #0551 iSeries Rack ▶ #5074 PCI Expansion Tower ▶ #5101/#5111 30 Disk Expansion with Dual Line Cords <p>Supported on Models 520, 550, 570, 595, 810, 820, 825, 830, 840, 870, and 890. The #0123 is withdrawn from marketing as of 03 December 2002.</p>
#0126	<p>#0126 CEC EIA Reduction Option</p> <p>The #0126 CEC EIA Reduction Option ships the Model 595, 870 or Model 890 system unit tower in two pieces from IBM to be fully assembled at the client's location. The tallest part of the system unit tower is reduced 14 inches (35cm) from 80 inches (2 m) to 66 inches (1.65m). The shipping pallet and packing materials add to the dimensions to allow for clearance.</p> <p>Supported on Models 595, 870 and 890. The #0126 is not a Customer Install Feature.</p>
#0133	<p>#0133 Plant Install in Rack</p> <p>The #0133 Plant Install in Rack feature is used to mount a Model 800 or 810 system unit (sidecar feature must be present) in a #0551 iSeries Rack either in the plant or in the field. The #0133 can be ordered on initial orders, MES orders or on model upgrades into the Model 810.</p> <p>The system is mounted in the #0551 at the plant if the system order received at the plant contains a system unit, #7116 System Unit Expansion, #0551 iSeries Rack, and #0133 Plant Install in Rack. If any of those four components are missing from the order, the system is not mounted in the #0551 at the plant.</p> <p>If the system is not installed in a #0551 iSeries Rack in the plant, the #0133 feature provides the following hardware components: a set of slides, cable management arm, a heavy duty tray, a Model 800 or 810 adapter plate and a pair of Model 800 or 810 lift covers.</p> <p>A line cord for both the system unit and the system unit expansion is required. For system units being mounted in the upper portions of a rack and <i>not</i> using the #1422 PDU Line Cord, be sure that the line cord (and SPCN cable, if present) is of sufficient length.</p> <p>A #7116 System Unit Expansion must be present or ordered for Models 800 and 810.</p> <p>An #0551 iSeries Rack is required for mounting a Model 800 or 810, but the #0551 is not required on the order, or on the inventory records for the system for which the #0133 Plant Install in Rack is ordered. Supported on Models 800 and 810. The #0133 is a Customer Install Feature if installed in the field. The #0133 is withdrawn from marketing as of 01 June 2006.</p>
#0134	<p>#0134 Field Install in Rack (HD)</p> <p>The #0134 Field Install in Rack (HD) is used to mount a Model 825 system unit in an #0551 iSeries Rack. The #0134 provides a set of slides, a cable management arm, a heavy duty tray, a Model 825 adapter plate, and a pair of Model 825 lift covers.</p> <p>Two line cords are required for the system unit. Be sure that the line cord (and SPCN cable, if present) is of sufficient length for system units mounted in the upper portions of a rack and not using the #1422 PDU Line Cord.</p> <p>An #0551 iSeries Rack is required for mounting the Model 825, but the #0551 is not required on the order or on the inventory records for the system for which the #0134 Field Install in Rack (HD) is ordered. The #0134 can be specified on an initial, model upgrade, or MES order. Supported on Model 825. The #0134 is a Customer Install Feature. The #0134 is withdrawn from marketing as of 21 November 2003.</p>
#0135	<p>#0135 Rear Cover</p> <p>The #0135 provides a single-wide rear cover for a Model 800 or 810 system unit without a #7116 System Unit Expansion installed. Supported on Models 800, 810 single wide The #0135 is a Customer Install Feature. The #0135 is withdrawn from marketing as of 01 June 2006.</p>

#0136	<p>#0136 Rear Cover The #0136 provides a double-wide rear cover for a Model 800 or 810 system unit with a #7116 System Unit Expansion installed. Supported on Models 800, 810 double wide The #0136 is a Customer Install Feature. The #0136 is withdrawn from marketing as of 01 June 2006.</p>
#0137	<p>#0137 Field Install in Rack The #0137 Field Install in Rack feature is used to mount a Model 800 or 810 system unit #7116 System Unit Expansion (must be present) in a #0551 iSeries Rack in the field. This feature provides a set of slides, cable management arm, a heavy duty ray, an 800 or 810 adapter plate and a pair of 800 or 810 lift covers. Requires a line cord for both the system unit and the system unit expansion. For system units being mounted in the upper portions of a rack and <i>not</i> using the #1422 PDU Line Cord, be sure that the line cord (and SPCN cable, if present) is of sufficient length. A #0551 iSeries Rack is required for mounting the Model 800 and 810, but the #0551 feature is not required on the order or on the inventory records for the system that is ordering a #0137. The #0137 can be specified on any type of order (initial, model upgrades into a Model 810 or simple MES). Supported on Models 800 and 810. The #0137 is an IBM Customer Service Representative setup feature. The #0137 is withdrawn from marketing as of 01 June 2006.</p>
#0138	<p>#0138 Field Install in Rack The #0138 Field Install in Rack feature is used to mount a Model 825 system unit in a #0551 iSeries Rack. This feature provides a set of slides, cable management arm, a tray, a Model 825 adapter plate and a pair of Model 825 lift covers. The #0138 can be specified on any type of order (initial, model upgrade or simple MES). For system units being mounted in the upper portions of a rack and <i>not</i> using the #1422 PDU Line Cord, be sure that the line cord (and SPCN cable, if present) is of sufficient length. A #0551 iSeries Rack is required for mounting the Model 825. The #0551 feature is not required on the order or on the inventory records for the system that is ordering a #0138. Supported on Model 825. The #0138 is an IBM Customer Service Representative setup feature. The #0138 is withdrawn from marketing as of 01 June 2006.</p>
#0140	<p>#0140 Logical Partitioning Specify The #0140 is used to specify that this system is to be logically partitioned. The #0140 is only valid on n-way processors with OS/400 V4R5 or later. The #0140 is valid on select OS/400 V5R1 supported uni-processors (IStar and SStar processors only). The IBM marketing configurator adds a quantity of one #0140 to the order for each logical partition (LPAR) required. Supported on Models 520, 550, 570, 595, 800, 810, 820, 825, 830, 840, 870 and 890. The #0140 is a Customer Install Feature.</p>
#0141	<p>#0141 HSL OptiConnect Specify The #0141 is used to specify that this system is to be part of a cluster using HSL OptiConnect. This feature is used to allow the ordering of additional HSL cables to connect the systems that have OptiConnect. Requires an HSL OptiConnect capable system. Maximum: One Minimum operating system level: OS/400 V5R1 Supported on Models 520, 550, 570, 595, 800, 810, 820, 825, 830, 840, 870, and 890. The #0141 is a Customer Install Feature.</p>

#0142	<p>#0142 Linux® Partition Specify</p> <p>The #0142 is used to specify that this system is to be logically partitioned with a Linux partition. Specify one #0142 for each Linux partition required. There are no minimum number of Linux direct attached features required per Linux partition. A Linux partition can exist without any Linux direct attached features in it (in this case, virtual storage, virtual LAN and virtual console is virtualized through the iSeries server).</p> <p>The following Linux direct attach features can be directly attached to a Linux partition. Linux direct attached features cannot be accessed by OS/400 and i5/OS partitions:</p> <ul style="list-style-type: none"> ▶ #0601 - Direct Attach #2743 PCI 1 Gbps Ethernet IOA ▶ #0602 - Direct Attach #2760 PCI 1 Gbps Ethernet UTP IOA ▶ #0603 - Direct Attach #2744 PCI 100 Mbps Token-Ring IOA (withdrawn from marketing as of 01 June 2006) ▶ #0604 - Direct Attach #2763 PCI RAID Disk Unit Controller ▶ #0605 - Direct Attach #4748 PCI RAID Disk Unit Controller ▶ #0606 - Direct Attach #4778 PCI RAID Disk Unit Controller ▶ #0607 - Direct Attach #4838 PCI 100/10 Mbps Ethernet IOA ▶ #0608 - Direct Attach #4745 PCI WAN IOA (withdrawn from marketing as of 01 June 2006) ▶ #0609 - Direct Attach #2772 PCI Dual WAN/Modem IOA (withdrawn from marketing as of 01 June 2006) ▶ #0610 - Direct Attach #2773 PCI Dual WAN/ModemIOA (AP only) ▶ #0611 - Direct Attach #2765 PCI Fibre Channel Tape Controller (withdrawn from marketing for new orders only on 01 April 2005) ▶ #0612 - Direct Attach #2766 PCI Fibre Channel Disk Controller (withdrawn from marketing for new orders only on 01 April 2005) ▶ #0613 - Direct Attach #2742 PCI 2-Line WAN IOA ▶ #0614 - Direct Attach #2793 PCI 2-Line WAN w/Modem ▶ #0615 - Direct Attach #2794 PCI 2-Line WAN w/Modem (AP only) ▶ #0616 - Direct Attach #2805 PCI Quad Modem IOA ▶ #0617 - Direct Attach #2806 PCI Quad Modem (CIM) (AP only) ▶ #0618 - Direct Attach #2757 PCI-X Ultra RAID Disk Controller (withdrawn from marketing as of 01 June 2006. ▶ #0619 - Direct Attach #2782 PCI-X RAID Disk Unit Controller ▶ #0620 - Direct Attach #5700 PCI 1 Gbps Ethernet IOA ▶ #0621 - Direct Attach #5701 PCI 1 Gbps Ethernet UTP IOA ▶ #0623 - Direct Attach #2849 PCI 100/10 Mbps Ethernet IOA (withdrawn from marketing as of 01 June 2006. #0620 - Direct Attach #5700 PCI 1 Gbps Ethernet IOA is the recommended replacement) ▶ #0621 - Direct Attach #5701 PCI 1 Gbps Ethernet UTP IOA ▶ #0623 - Direct Attach #2849 PCI 100/10 Mbps Ethernet IOA (withdrawn from marketing as of 01 June 2006. #0620 - Direct Attach #5700 PCI 1 Gbps Ethernet IOA is the recommended replacement) ▶ #0624 - Direct Attach #5702 PCI-X Ultra Tape Controller (withdrawn from marketing as of 1 June 2006. #0645 - Direct Attach #5712 PCI-X Tape/DASD Controller is the recommended replacement.) ▶ #0625 - Direct Attach #5704 PCI-X Fibre Channel Tape Controller ▶ #0626 - Direct Attach #2787 PCI-X Fibre Channel Disk Controller ▶ #0627 - Direct Attach #2780 PCI-X Ultra4 RAID Disk Controller ▶ #0628 - Direct Attach #5703 PCI-X RAID Disk Unit Controller ▶ #0632 - PCI USB 2.0 Adapter ▶ #0633 - Graphics Adapter ▶ #0634 - 128-port Asynchronous Adapter ▶ #0635 - SDLC/X.25 - 2-port Adapter ▶ #0643 - Direct Attach #5706 PCI-X Gbps Ethernet-TX IOA ▶ #0644 - Direct Attach #5707 PCI-X 1 Gbps Ethernet-SX IOA ▶ #0645 - Direct Attach #5712 PCI-X Tape/DASD Controller ▶ #0646 - Direct Attach #5716 2 Gb Fibre Channel PCI-X Adapter ▶ #0647 PCI-X Disk/Tape Controller without IOP ▶ #0648 PCI-X Disk Controller 90MB without IOP <p>See the descriptions of the individual feature to understand the capabilities and PCI slot limitations of the features directly attached to Linux partitions.</p> <p>Linux direct attach features do not use or require PCI IOPs. They are only supported in a secondary LPAR partition and require a minimum operating system level of OS/400 V5R1 running in the primary partition.</p> <p>Corequisite: #0140 Logical Partition Specify.</p> <p>Maximum: Up to one less than the total number of partitions allowed on system/processor.</p> <p>Linux partitions are supported with SUSE Linux Enterprise Server 9 for POWER™ or Red Hat Enterprise Linux AS for POWER Version 3.</p> <p>AIX partitions are supported with AIX 5L™ for POWER V5.2.</p> <p>Minimum operating system level: OS/400 V5R1</p>
-------	---

#0142 (cont.)	<p>#0142 Linux Partition Specify Supported on Models 520, 550, 570, 595, 800, 810, 820, 825, 830, 840, 870, and 890. The #0142 is a Customer Install Feature. The #0601 is withdrawn from marketing as of 01 October 2004. A #0620 is the recommended replacement. The #0602 is withdrawn from marketing as of 01 October 2004. A #0621 is the recommended replacement. The #0605 is withdrawn from marketing for new orders. It is supported as the target of feature conversions. The #0606 is withdrawn from marketing as of 19 November 2004. A #0618 is the recommended replacement. The #0611 is withdrawn from marketing as of 01 April 2005 for new orders. It is supported as the target of feature conversions. The #0612 is withdrawn from marketing as of 01 April 2005 for new orders. It is supported as the target of feature conversions.</p>
#0145	<p>#0145 AIX Partition Specify The #0145 is used to specify that this system is to be logically partitioned with an AIX partition. A quantity of one #0145 is required on the order/inventory records for each AIX partition required.</p> <p>AIX features are only allowed within AIX partitions. AIX features are not allowed in i5/OS partitions.</p> <p>There is no minimum number of AIX direct-attached features required per AIX partition. The system provides virtual I/O for those AIX partitions that do not contain AIX features. Corequisite: #0140 Logical Partition Specify.</p> <p>Minimum operating system level: i5/OS V5R3 Supported on Models 520, 550, 570, and 595 The #0145 is a Customer Install Feature.</p>
#0205	<p>#0205 RISC-to-RISC Data Migration The #0205 RISC-to-RISC Data Migration specify code is used when a client orders a new (RISC) iSeries server to replace an existing AS/400e RISC-based system. The #0205 is ordered on the initial order of a Model 520, 550, 570, 595, 800, 810, 820, 825, 830, 840, 870, or 890. Manufacturing loads only the System Licensed Internal Code (SLIC) up through QSYS of OS/400 when the #0205 is ordered. Because of this limited loading of OS/400 by manufacturing, #5000 Software Preload Required is not allowed with the #0205. The #0205 RISC-to-RISC Data Migration and #5000 Software Preload Required are mutually exclusive.</p> <p>The #0205 is withdrawn from marketing as of 01 April 2005 for 9405 Model 520.</p>
#0272	<p>#0272 Renovated by IBM The #0272 Renovated by IBM feature is a specify code used to indicate that the system is to be built from new or refurbished parts. Supported on Models 800, 810, 820, 825, 830, 840, 870, and 890.</p>
#0299	<p>#0299 MES Conversion Analysis for #5580/5581 MES July 2005 The #0299 provides additional ordering/scheduling steps for clients adding Auxiliary Write Cache IOA to existing large cache disk controllers (converting #2757, #2780, to #5580, #5581). The IBM Marketing Configurator adds no-charge #0299 feature to the order to "flag" a conversion. The automated tool analyzes current MRPD configuration to determine if simple MES or potentially more complex MES. The order is scheduled if simple MES or upon confirmation the sales team has done planning for complex MES. For more details regarding Auxiliary Write Cache, refer to the following IBM Redpaper: http://w3.itso.ibm.com/redpieces/abstracts/redp4003.html?Open</p> <p>Minimum operating system level: OS/400 V5R2 with Cumulative PTF package C5102530 and prerequisite PTFs or i5/OS V5R3 with Cumulative PTF package C5102530 and prerequisite PTFs. Supported on Models 270, 520, 550, 570, 595, 800, 810, 820, 825, 830, 840, 870, 890, and 9411-100.</p>
#0454	<p>#0454 - LPAR Partition Init The #0454 configures a partition and assigns the correct resources as specified by the customer. Feature is only available for Models 570 and 595. The #0454 is not a Customer Install Feature.</p>
0455	<p>#0455 - LPAR OS Preload The #0455 loads the operating system (i5/OS or AIX 5L) specified by the client for a partition configured via #0454 LPAR Partition Initialization. Supported on Models 570 and 595. The #0455 is not a Customer Install Feature.</p>

#0496	<p>#0496 - Force i5/OS Preload</p> <p>The #0496 preloads i5/OS on a new server. The #0496 forces a preload of i5/OS on a single partition when Linux or AIX 5L partitions with virtual storage are on the order. i5/OS is preloaded on all the disk drives in the configuration. Do not use this feature if the Linux or AIX 5L partition has dedicated disk controllers and drives in the on order configuration. The #0496 is mutually exclusive with a #0006.</p> <p>Supported on Models 520, 550, 570, 595, 520+, 550+, 570+, and 595. The #0496 is not a Customer Install Feature.</p>
#0551	<p>#0551 iSeries Rack</p> <p>The #0551 iSeries Rack provides an empty 1.8 m rack which contains 36 EIA units of space. The following features specify the means of populating the #0551:</p> <ul style="list-style-type: none"> ▶ #0121 Lower Unit in Rack Specify ▶ #0122 Upper Unit in Rack Specify ▶ #0123 - #5074 Lower Unit in Rack ▶ #0125 - #9079 Lower Unit in Rack ▶ #0127 - 270 Field Install in Rack ▶ #0133 Plant Install in Rack ▶ #0134 Field Install in Rack (HD) ▶ #0137 Field Install in Rack ▶ #0138 Field Install in Rack ▶ #0578 PCI Expansion Unit in Rack ▶ #0588 PCI-X Expansion Unit in Rack ▶ #0595 PCI-X Expansion Unit in Rack ▶ #7884 520 Rack Mount <p>The #0578/#0588 can be installed in the same rack as a Model 270 but cannot be connected to the Model 270. The #0595 can be attached to a Model 270.</p> <p>Optional features for the #0551 iSeries Rack are:</p> <ul style="list-style-type: none"> ▶ #6068 Optional Front Door (black/flat) ▶ #6580 Optional Rack Security Kit ▶ #7840 Side-by-Side for 1.8m Racks ▶ #7841 Ruggedize Rack Kit <p>The IBM marketing configurator does not manage rack space in the #0551 iSeries Rack. See 6.2, "Required EIA units" on page 289 to determine the number of EIA units required in the #0551 for each Hardware Management Console (HMC), System i system unit or expansion tower.</p> <p>One to four PDUs can be ordered with the #0551 iSeries Rack. The PDUs can be on initial orders, model upgrades, or on MES orders. Each PDU has six power sockets that can be used to provide power for devices rack mounted in the #0551 iSeries Rack using the #1422 PDU Line Cord.</p> <p>The following PDUs are supported:</p> <ul style="list-style-type: none"> ▶ #5160 Power Distribution Unit 1 Phase NEMA (6 sockets) (withdrawn from marketing as of 12 April 2005. A #7188 Power Distribution Unit Side Mount is the recommended replacement.) <p>The following line cords are supported on the #5160 for connection to utility power:</p> <ul style="list-style-type: none"> – #1424 - 200V 6-ft Locking Line Cord – #1425 - 200V 6-ft Watertight Line Cord – #1426 - 200V 14-ft Locking Line Cord – #1427 - 200V 14-ft Watertight Line Cord – #1446 - 4.3m 200V/30A Power Cord Korea – #1447 - 4.3m 200V/30A Power Cord AU – #1448 - 4.3m 200V/30A Power Cord NZ

#0551
(cont.)

#0551 iSeries Rack

- ▶ #5161 Power Distribution Unit - 1 Phase IEC (6 sockets) (withdrawn from marketing as of 12 April 2005. A #7188 Power Distribution Unit Side Mount is the recommended replacement.)
 - #1477 - 4.3m 200V/ 16A IEC309/46 Power Cord
 - #1449 - 4.3m 200V/ 32A Power Cord EU 1-Phase for connection to utility power.
- ▶ #5162 Power Distribution Unit - 2 of 3 Phase
 - #1450 - 4.3m 200V/ 16A Power Cord EU 2-Phase for connection to utility power.
- ▶ #5163 Power Distribution Unit - 3 Phase (6 sockets) (withdrawn from marketing as of 12 April 2005. A #7188 Power Distribution Unit Side Mount is the recommended replacement.)
 - #1477 - 4.3m 200V/ 16A IEC309/46 Power Cord
- ▶ #7188 Power Distribution Unit 1 Phase NEMA
The #7188 PDU is the replacement for the #5160, #5161, #5162 and #5163.
The following line cords are supported on the #7188 to connect to utility power:
 - #6489 - 14-ft 3PH/24A Power Cord
 - #6491 - 14-ft 1PH/63A Power Cord
 - #6492 - 14-ft 1PH/48-60A Power Cord
 - #6653 - 14-ft 3PH/16A Power Cord
 - #6654 - 14-ft 1PH/24-30A Power Cord
 - #6655 - 14-ft 1PH/24-30A Watertight Power Cord
 - #6656 - 14-ft 1PH/24A Power Cord
 - #6657 - 14-ft 3PH/24A Power Cord
 - #6658 - 14-ft 3PH/16A Power Cord Korea

Supported on Models 520, 550, 570, 595, 800, 810, 820, 825, 830, 840, 870, and 890.
The #0551 is a Customer Install Feature.

#0553	<p>#0553 iSeries 2.0 m Rack</p> <p>The #0553 iSeries 2.0 m Rack provides a 2 m rack which contains 42 EIA units of space. The following features specify the means of populating the #0553:</p> <ul style="list-style-type: none"> ▶ #0133 Plant Install in Rack ▶ #0137 Field Install in Rack ▶ #0138 Field Install in Rack ▶ #0578 PCI Expansion Unit in Rack ▶ #0588 PCI-X Expansion Unit in Rack ▶ #0595 PCI-X Expansion Unit in Rack ▶ #7798 Model 550 non-IBM Rack Mount ▶ #7880 Side Attach Kit for Rack ▶ #7883 Model 520 non-IBM Rack Mount ▶ #7884 520 Rack Mount ▶ #7886 550 Rack Mount <p>One of the following features is required on the #0553:</p> <ul style="list-style-type: none"> ▶ #6069 Optional Front Door for 2.0m Rack ▶ #6247 2.0m Rack Trim Kit ▶ #6249 - 2.0m Rack Acoustic Doors <p>Optional features for the #0553 rack:</p> <ul style="list-style-type: none"> ▶ #6580 Optional Rack Security Kit ▶ #7780 2.0m Rack Side Attach Kit ▶ #7841 Ruggedize Rack Kit <p>The #0553 can support up to nine PDUs, four mounted vertically and five mounted horizontally. Horizontally mounted PDUs occupy one EIA of rack space. The IBM marketing configurator does not manage rack space in the #0553 iSeries 2.0 m Rack. See 6.2, "Required EIA units" on page 289 to determine the number of EIA units required in the #0553 for each Hardware Management Console (HMC), System i system unit or expansion tower.</p> <p>The PDUs can be ordered on initial orders, model upgrades, or on MES orders. Each #5160, #5161, #5162 and #5163 PDU has six power sockets and the #7188 Power Distribution Unit has 12 power sockets that can be used to provide power for rack mounted devices in the #0553 iSeries rack using the #1422 or #6458 PDU Power Cord. Only #7188 PDUs can be mixed with other PDU features. Otherwise, no mixing of PDU types or features within a #0553 or on a system is allowed.</p> <p>The following PDUs are supported:</p> <ul style="list-style-type: none"> ▶ #5160 Power Distribution Unit 1 Phase NEMA (6 sockets) (withdrawn from marketing as of 12 April 2005. A #7188 Power Distribution Unit Side Mount is the recommended replacement.) <p>The following line cords are supported on the #5160 for connection to utility power:</p> <ul style="list-style-type: none"> - #1424 - 200V 6-ft Locking Line Cord - #1425 - 200V 6-ft Watertight Line Cord - #1426 - 200V 14-ft Locking Line Cord - #1427 - 200V 14-ft Watertight Line Cord - #1446 - 4.3m 200V/30A Power Cord Korea - #1447 - 4.3m 200V/30A Power Cord AU - #1448 - 4.3m 200V/30A Power Cord NZ
-------	--

#0553
(cont.)

#0553 iSeries Rack

- ▶ #5161 Power Distribution Unit - 1 Phase IEC (6 sockets) (withdrawn from marketing as of 12 April 2005. A #7188 Power Distribution Unit Side Mount is the recommended replacement.)
 - #1449 - 4.3m 200V/32A Power Cord EU 1-Phase for connection to utility power
- ▶ #5162 Power Distribution Unit
 - #1450- 4.3m 200V/16A Power Cord EU 2-Phase for connection to utility power
- ▶ #5163 Power Distribution Unit - 3 Phase (6 sockets) (withdrawn from marketing as of 12 April 2005. A #7188 Power Distribution Unit Side Mount is the recommended replacement.)
 - #1477 - 200V 16A 14-ft IEC 309/46 Line Cord
- ▶ #7188 Power Distribution Unit 1 Phase NEMA

The #7188 PDU is the replacement for the #5160, #5161, #5162 and #5163.
The following line cords are supported on the #7188 to connect to utility power:

 - #6489 - 14-ft 3PH/24A Power Cord
 - #6491 - 14-ft 1PH/63A Power Cord
 - #6492 - 14-ft 1PH/48-60A Power Cord
 - #6653 - 14-ft 3PH/16A Power Cord
 - #6654 - 14-ft 1PH/24-30A Power Cord
 - #6655 - 14-ft 1PH/24-30A Watertight Power Cord
 - #6656 - 14-ft 1PH/24A Power Cord
 - #6657 - 14-ft 3PH/24A Power Cord
 - #6658 - 14-ft 3PH/16A Power Cord Korea

All rack-mounted units plugging into a PDU require either a #1422 or #6458 PDU Power Cord. Mixing of different system models within a single #0553 2.0m rack is not allowed on initial order systems. PDU features can be ordered without a #0553 rack being ordered or present on the system.

Supported on Models 520, 550, 570, 595, 800, 810, 825, 870, 890.
The #0553 is a Customer Install Feature.

#0554	<p>#0554 iSeries 11U Rack</p> <p>The #0554 iSeries 11U Rack provides a 19-inch, .6m (24-inch) high rack with 11 EIA units of total space for installing rack mounted system units and/or expansion units. The #0554 includes a lockable front door. Filler panels and a perforated front door are included to help provide proper airflow and cooling. A rear door is not offered.</p> <p>The following feature is orderable on the #0554:</p> <ul style="list-style-type: none"> ▶ #0599 - Rack Filler Panel Kit (if extra filler panels are required) <p>The following PDUs are supported:</p> <ul style="list-style-type: none"> ▶ #5160 Power Distribution Unit 1 Phase NEMA (6 sockets) (withdrawn from marketing as of 12 April 2005. A #7188 Power Distribution Unit Side Mount is the recommended replacement.) <p>The following line cords are supported on the #5160 for connection to utility power:</p> <ul style="list-style-type: none"> - #1424 - 200V 6-ft Locking Line Cord - #1425 - 200V 6-ft Watertight Line Cord - #1426 - 200V 14-ft Locking Line Cord - #1427 - 200V 14-ft Watertight Line Cord - #1446 - 4.3m 200V/30A Power Cord Korea - #1447 - 4.3m 200V/30A Power Cord AU - #1448 - 4.3m 200V/30A Power Cord NZ <ul style="list-style-type: none"> ▶ #5161 Power Distribution Unit - 1 Phase IEC (6 sockets) (withdrawn from marketing as of 12 April 2005. A #7188 Power Distribution Unit Side Mount is the recommended replacement.) <p>The following line cord is supported on the #5161 for connection to utility power:</p> <ul style="list-style-type: none"> - #1449 - 4.3m 200V/32A Power Cord EU 1-Phase <ul style="list-style-type: none"> ▶ #5162 Power Distribution Unit 2 of 3 Phase (6 sockets) (supported, not orderable) <p>The following line cord is supported on the #5162 for connection to utility power:</p> <ul style="list-style-type: none"> - #1450- 4.3m 200V/16A Power Cord EU 2-Phase <ul style="list-style-type: none"> ▶ #5163 Power Distribution Unit - 3 Phase (6 sockets) (withdrawn from marketing as of 12 April 2005. A #7188 Power Distribution Unit Side Mount is the recommended replacement.) <ul style="list-style-type: none"> ▶ #7188 Power Distribution Unit 1 Phase NEMA (12 sockets) (orderable) <p>The #7188 PDU is the replacement for the #5160, #5161, #5162 and #5163.</p> <p>The following line cords are supported on the #7188 to connect to utility power:</p> <ul style="list-style-type: none"> - #6489 - 14-ft 3PH/24A Power Cord - #6491 - 14-ft 1PH/63A Power Cord - #6492 - 14-ft 1PH/48-60A Power Cord - #6653 - 14-ft 3PH/16A Power Cord - #6654 - 14-ft 1PH/24-30A Power Cord - #6655 - 14-ft 1PH/24-30A Watertight Power Cord - #6656 - 14-ft 1PH/32A Power Cord - #6657 - 14-ft 3PH/24A Power Cord - #6658 - 14-ft 3PH/16A Power Cord Korea <p>The IBM marketing configurator does not manage rack space in the #0554 iSeries Rack. See 6.2, "Required EIA units" on page 289 to determine the number of EIA units required in the #0554 for each Hardware Management Console (HMC), System i system unit or expansion tower. Mixing of different system models within a single #0554 is not allowed on initial order systems. The #0554 supports up to six Power Distribution Units (PDU) that are mounted horizontally. Each PDU takes up one EIA of rack space.</p> <p>All rack-mounted units plugging into a PDU require a PDU line cord with a C14 plug, #1422 or #6458 PDU Power Cord. Mixing of different system models within a single #0553 2.0m rack is not allowed on initial order systems. For system units mounted in the upper portions of a rack and not using the #1422 or #6458 PDU Power Cord, be sure the line cord (and SPCN cable, if present) is of sufficient length. PDU features can be ordered without a #0554 rack being ordered or present on the system.</p> <p>Supported on Models 520, 550, 570, 595, 800, 810, 825, 870, 890. The #0554 is a Customer Install Feature.</p>
-------	--

#0555

#0555 iSeries 25U Rack

The #0555 provides a 19-inch, 1.3m (49-inch) high rack with 25 EIA units of total space for installing rack-mounted system units and/or expansion units. The #0555 includes lockable front and rear doors. Filler panels and perforated doors are included to help provide proper airflow and cooling.

The following feature is orderable on the #0555:

- ▶ #0599 - Rack Filler Panel Kit (if extra filler panels are required)

The IBM marketing configurator does not manage rack space in the #0555 iSeries Rack. See 6.2, "Required EIA units" on page 289 to determine the number of EIA units required in the #0555 for each Hardware Management Console (HMC), System i system unit or expansion tower. Mixing of different system models within a single #0554 is not allowed on initial order systems. The #0555 supports up to six Power Distribution Units (PDU) that are mounted horizontally. Each PDU takes up one EIA of rack space.

The following PDUs are supported:

- ▶ #5160 Power Distribution Unit 1 Phase NEMA (6 sockets) (withdrawn from marketing as of 12 April 2005. A #7188 Power Distribution Unit Side Mount is the recommended replacement.)

The following line cords are supported on the #5160 for connection to utility power:

- #1424 - 200V 6-ft Locking Line Cord
- #1425 - 200V 6-ft Watertight Line Cord
- #1426 - 200V 14-ft Locking Line Cord
- #1427 - 200V 14-ft Watertight Line Cord
- #1446 - 4.3m 200V/30A Power Cord Korea
- #1447 - 4.3m 200V/30A Power Cord AU
- #1448 - 4.3m 200V/30A Power Cord NZ

- ▶ #5161 Power Distribution Unit - 1 Phase IEC (6 sockets) (withdrawn from marketing as of 12 April 2005. A #7188 Power Distribution Unit Side Mount is the recommended replacement.)

The following line cord is supported on the #5161 for connection to utility power:

- #1449 - 4.3m 200V/32A Power Cord EU 1-Phase

- ▶ #5162 Power Distribution Unit 2 of 3 Phase (6 sockets) (supported, not orderable)

The following line cord is supported on the #5162 for connection to utility power:

- #1450 - 4.3m 200V/16A Power Cord EU 2-Phase

- ▶ #5163 Power Distribution Unit - 3 Phase (6 sockets) (withdrawn from marketing as of 12 April 2005. A #7188 Power Distribution Unit Side Mount is the recommended replacement.)

- ▶ #7188 Power Distribution Unit 1 Phase NEMA (12 sockets) (orderable)

The #7188 PDU is the replacement for the #5160, #5161, #5162 and #5163. The following line cords are supported on the #7188 to connect to utility power:

- #6489 - 14-ft 3PH/24A Power Cord
- #6491 - 14-ft 1PH/63A Power Cord
- #6492 - 14-ft 1PH/48-60A Power Cord
- #6653 - 14-ft 3PH/16A Power Cord
- #6654 - 14-ft 1PH/24-30A Power Cord
- #6655 - 14-ft 1PH/24-30A Watertight Power Cord
- #6656 - 14-ft 1PH/32A Power Cord
- #6657 - 14-ft 3PH/24A Power Cord
- #6658 - 14-ft 3PH/16A Power Cord Korea

All rack-mounted units plugging into a PDU require a PDU line cord with a C14 plug, #1422 or #6458 PDU Power Cord. Mixing of different system models within a single #0555 iSeries Rack is not allowed on initial order systems. PDU features can be ordered without a #0555 rack being ordered or present on the system. For system units mounted in the upper portions of a rack and not using the #1422 or #6458 PDU cord, be sure the line cord (and SPCN cable, if present) is of sufficient length.

Supported on Models 520, 550, 570, 595, 800, 810, 825, 870, 890.

The #0555 is a Customer Install Feature.

#0574	<p>#0574 - #5074 Equivalent The #0574 indicates a #5074 installed in a #5079 rack. The #0574 PCI Expansion Unit in Rack is the equivalent of a #5074 PCI Expansion Tower, but the #0574 is installed in an #5079 1.8 m I/O Tower.</p> <p>For each #5079 ordered, a default quantity of two #0574 specify codes appear on the order (one #0574 can be removed from the #5079 order). #0574s can be RPQ added/removed to/from system inventory records, but at least one #0574 must exist for each #5079 on the inventory records. If an existing #5079 is to be shared between two systems, one #0574 must be RPQ removed from that system the #5079 was ordered against and one #0574 must be RPQ added to the other sharing system.</p> <p>Requires a #5079.</p> <p>Supported on Models 9406 520, 550, 570, 595, 520+, 550+, 570+, 595 1.9 GHz and 9411-100. CSU does not apply as the #0574 is rack mounted.</p>
#0578	<p>#0578 PCI Expansion Unit in Rack The #0578 PCI Expansion Unit in Rack is the equivalent of a #5078 PCI Expansion Unit, but the #0578 is mounted in an #0550, #0551, #0553, #0554, or #0555 iSeries Rack. An #0578 is eight EIA units high. Conversions between an #0578 and a #5078 are not allowed.</p> <p>Up to five #0578s are mounted in a #0551, #0553, #0554, or #0555 iSeries Rack depending on the amount of existing empty space in the #0551, #0553, #0554, and #0555. One #0578 can be mounted in an #0550 iSeries Rack. The #0578 can be ordered on initial, upgrade, and MES orders. The #0578 comes with two PDU-compatible power cords.</p> <p>A minimum of one PDU is required if one, two, or three #0578s are ordered to be installed in the same #0551, #0553, #0554, and #0555. A minimum of two PDUs are required if four #0578s are ordered for the same #0551 iSeries Rack. One PDU is required for an #0578 in an #0550. Each PDU has six power sockets for connecting rack mounted devices via #1422 PDU Line Cord. Each #0578 comes with two integrated PDU compatible line cords. The #1422 PDU Line Cords are <i>not</i> usable with this expansion unit. See the #0551, #0553, #0554, and #0555 feature descriptions for a list of available PDUs. See “#5078 PCI Expansion Unit” on page 115 for a description of #0578 and #5078 common features.</p> <p>Supported on Models 810, 820, 825, 830, 840, 870, and 890. The #0578 is not a Customer Install Feature. The #0578 is withdrawn from marketing as of 01 October 2004. A #0588 is the recommended replacement.</p>
#0588	<p>#0588 PCI-X Expansion Unit in Rack The #0588 PCI-X Expansion Unit in Rack is the equivalent of a #5088 PCI-X Expansion Unit, but the #0588 is mounted in an #0550, #0551, #0553, #0554, or #0555 iSeries Rack. An #0588 is 8 EIA units high. Conversions between an #0588 and a #5088 are not allowed.</p> <p>The #0588 PCI-X Expansion Unit in Rack has two redundant 575W power supplies and two integrated PDU compatible line cords. The line cords can be connected to the same PDU or separate PDUs in the #0550, #0551, #0553, #0554, and #0555 iSeries Racks. If the line cords are connected to separate PDUs, and these PDUs are connected to two different power sources, then the #0588 has dual line cord capability. A minimum of one PDU is required if one, two or three #0588s are ordered to be installed in the same #0551, #0553, #0554, or #0555. A minimum of two PDUs are required if four #0588s are ordered for the same #0551, #0553, #0554, or #0555. One PDU is required for an #0588 in an #0550. The #1422 PDU Line Cords are not usable with the #0588. See the #0551, #0553, #0554, and #0555 descriptions for a list of available PDUs.</p> <p>Up to five #0588s can be mounted in a #0551, #0553, #0554, or #0550 iSeries Racks (depending on the amount of existing empty space in the iSeries rack) and one #0588 can be mounted in a #0550 iSeries Rack. The #0588 can be ordered on initial, model upgrade, or MES orders.</p> <p>A #9943/#9844 Base PCI IOP can be used in a #0588 PCI-X Expansion Unit in Rack, but cannot be ordered with or for the #0588. See “#5088 PCI-X Expansion Unit” on page 117 for a description of #0588 and #5088 PCI-X Expansion Unit common features.</p> <p>The #0588 is also supported in Linux partitions with SUSE Linux Enterprise Server 9 for POWER or Red Hat Enterprise Linux AS for POWER Version 3.</p> <p>Minimum operating system level: OS/400 V5R2 Supported on Models 520, 550, 570, 595, 800, 810, 820, 825, 830, 840, 870, and 890. The #0588 is a Customer Install Feature. The #0588 is withdrawn from marketing as of 01 June 2006.</p>

#0595	<p>#0595 PCI-X Expansion Unit in Rack</p> <p>The #0595 PCI-X Expansion Unit in Rack is a five EIA high rack-mounted version of the #0595 PCI-X Expansion Unit in Rack, which provides I/O capability for iSeries servers. The #0595 has identical functional capabilities to the #5095. A #9844 Base PCI IOP is included as base for the #0595 PCI-X Expansion Unit in Rack.</p> <p>A #9517 Base HSL-2/RIO-G Bus Adapter is shipped for Models 520, 550, 570, and 595. A #9877 Base HSL-2 Bus Adapter is shipped with new orders of a #5094 for Models 800, 810, 820, 825, 830, 840, 870, and 890.</p> <p>The #0595 PCI-X Expansion Unit in Rack has redundant power when #5138 Redundant Power and Cooling is specified. The #5138 includes a second 435W power supply. A second line cord must be ordered and installed. With the #5138 and second line cord installed, the #0595 has dual line cord capability. If the #0595 is to be connected to a PDU, then one or two #1422 line cords must be ordered.</p> <p>Up to eight #0595s can be installed in a #0551/#0553/#0554/#0555 iSeries 25U Rack, depending on the amount of existing empty space in the #0551/#0553/#0554/#0555. See “#5095 PCI-X Expansion Tower” on page 120 for a description of #0595 and #5095 common features.</p> <p>The #0595 is also supported in Linux and AIX partitions with SUSE Linux Enterprise Server 9 for POWER or Red Hat Enterprise Linux AS for POWER Version 3; and AIX 5L for POWER V5.2.</p> <p>Minimum operating system level: OS/400 V5R2 Supported on Models 520, 550, 570, 595, 800, 810, 820, 825, 830, 840, 870, and 890. The #0595 is a Customer Install Feature. The tower and drawer configurations no longer include a #9844 Base PCI IOP as of 31 January 2006 with the announcement of IOP-less support in IBM System i5 and eServer i5 models.</p>
#0599	<p>#0599 Rack Filler Kit</p> <p>The #0599 Rack Filler Kit provides four spare filler Panels 3x 1U and 1x 3U height. They should be used if equipment is removed from racks to improve the appearance of the rack and to ensure and maintain proper air flow.</p> <p>Supported in IBM 19” racks such as #0551, #0553, #0554, #0555. Supported on Models 520, 550, 570, 595, 520+, 550+, 570+, 595 1.9 GHz. The #0599 is a Customer Install Feature.</p>
#0694	<p>#0694 - #5094 Equivalent</p> <p>The #0694 - #5094 Equivalent is used by the IBM marketing configurator to keep track of the number of #5094 PCI-X Expansion Tower rack-mounted units actually connected or cabled to the system.</p> <p>For each #5294 1.8m I/O Tower ordered, the IBM marketing configurator defaults a quantity of two #0694 specify codes to the order. One #0694 can be removed from the #5294 order. Process a Record Purposes Only (RPO) to add or remove the #0694s to or from system inventory records, but at least one #0694 must exist for each #5294 on the inventory records. If an existing #5294 is to be shared between two systems, process an RPO to remove one #0694 from the system that the #5294 was ordered against and to add one #0694 to the other sharing system.</p> <p>For each #8094 Optional 1.8 M I/O Rack ordered, the IBM marketing configurator defaults a quantity of one #0694 specify code on the order. The #0694 can be removed from the #8094 Optional 1.8 M I/O Rack via MES after the initial order if the rack-mounted #5094 PCI-X Expansion Tower does not attach to the same system as the #9094 Base PCI I/O Enclosure lower unit. In this case, record-purposes-only add the #0694 to the sharing system which attaches the #5094 tower.</p> <p>Minimum operating system level: OS/400 V5R2 Supported on Models 520, 550, 570, 595, 800, 810, 820, 825, 830, 840, 870, and 890. The #0694 is a Customer Install Feature. The tower and drawer configurations no longer include a #9844 Base PCI IOP as of 31 January 2006 with the announcement of dual mode IOAs in the IBM System i5 and eServer i5 servers.</p>
#0836	<p>#0836 - #4328 Load Source Specify</p> <p>The #0836 indicates that a #4328 Disk Unit is used as the load source. A load source specify code is required on each new or upgrade order into 520, 550, 570, or 595 models. These specify codes can be changed at any time.</p> <p>Supported on Models 520, 550, 570, 595, 520+, 550+, 570+, 595 1.9 GHz. The #0836 is a Customer Install Feature.</p>

#1800	<p>#1800 HSL-2 Ports - 2 Copper The #1800 HSL-2 Ports - 2 Copper is a two port copper HSL-2/RIO-G bus expansion card for the Model 570. The #1800 adds capacity for an additional HSL-2/RIO-G loop on to the system. Hot plug capability is supported. Requires a #7875 CPU Power Regulator.</p> <p>Slot 6 is unavailable when #1800 is installed.</p> <p>Minimum operating system level: i5/OS V5R3 The #1800 is a Customer Install Feature.</p>
#1801	<p>#1801 Optical Bus Expansion Card - 2 port The #1801 Optical Bus Expansion Card - 2 port is a two port optical RIO-G bus expansion card for the Model 570. The #1801 adds two optical ports, enabling capacity for an optical loop for the Model 570. The ability to concurrently add or remove an I/O tower or drawer is not supported. When installed, slot 6 is unavailable. Optical SPCN cables cannot be directly attached to the Model 570 system unit, but can be attached to an intermediate I/O tower/drawer on the same SPCN loop. Corequisite: #7875 CPU Power Regulator</p> <p>Supported on Model 570. Minimum operating system level: i5/OS V5R3 The #1801 is a Customer Install Feature.</p>
#1807	<p>#1807 RIO-G Ports - 2 optical The #1807 RIO-G Ports - 2 optical is a 2-port optical RIO-G bus expansion card for the Model 550. The #1807 adds two optical ports, enabling capacity for an optical loop.</p> <p>The ability to concurrently add or remove an I/O tower or drawer is not supported. Optical SPCN cables cannot be directly attached to the Model 550 system unit, but can be attached to an intermediate I/O tower or drawer on the same SPCN loop. Plugs into the optional HSL connector in the system unit and makes system unit slot C05 unusable for PCI card placement.</p> <p>Minimum operating system level: i5/OS V5R3, AIX 5L for Power V5.2, Red Hat Enterprise Linux AS for POWER Version 3, or SUSE Linux Enterprise Server 9 for POWER.</p> <p>Supported on Model 550. The #1807 is a Customer Install Feature.</p>
#2739	<p>#2739 Optical Bus Adapter The #2739 Optical Bus Adapter is used in the #5074 PCI Expansion Tower, #5079 1.8 m I/O Tower, and the #5078/#0578 PCI Expansion Unit in Rack to connect via optical HSL. The #2739 supports clustering (HSL OptiConnect).</p> <p>Minimum operating system level: OS/400 V5R1 Supported on Models 550, 570, 595, 825, 830, 840, 870, and 890. The #2739 is a Customer Install Feature.</p>
#2776	<p>#2776 HSL-2 Ports - 8 Copper The #2776 HSL-2 Ports - 8 Copper is an 8-port copper HSL-2 bus adapter which supports up to four HSL-2 loops.</p> <p>Minimum operating system level: OS/400 V5R2 Supported on Models 870 and 890. The #2766 is a Customer Install Feature. The #2776 is withdrawn from marketing as of 01 June 2006.</p>
#2785	<p>#2785 HSL-2 Ports - 2 Copper The #2785 HSL-2 Ports - 2 Copper is a 2-port copper HSL-2 adapter for the Model 825. The #2785 can be installed in either of the two HSL adapter slots (C08 or C09) on the Model 825 backplane.</p> <p>Minimum operating system level: OS/400 V5R2 Supported on Model 825. The #2785 is a Customer Install Feature. The #2785 is withdrawn from marketing as of 01 June 2006.</p>

#2786	<p>#2786 HSL Ports - 2 Optical The #2786 HSL Ports - 2 Optical is a 2-port optical HSL adapter for the Model 825. The #2786 can be installed in either of the two HSL adapter slots (C08 or C09) on the Model 825 backplane.</p> <p>Minimum operating system level: OS/400 V5R2 Supported on Model 825. The #2786 is a Customer Install Feature. The #2786 is withdrawn from marketing as of 01 June 2006.</p>
#2788	<p>#2788 HSL Ports - 8 Optical The #2788 HSL Ports - 8 Optical is an 8-port optical HSL-2 bus adapter, which supports up to four optical HSL-2 loops in Models 870 and 890.</p> <p>Minimum operating system level: OS/400 V5R2 Supported on Models 870 and 890. The #2788 is not a Customer Install Feature. The #2788 is withdrawn from marketing as of 01 June 2006.</p>
#3757	<p>#3757 Processor Book Service Shelf A #3757 Processor Book Service Shelf kit is required by IBM service personnel to add and to remove a Model 595 processor book. A minimum of one #3757 is required at each site with a Model 595 installed.</p> <p>Minimum operating system level: i5/OS V5R3 Supported on Model 595.</p>
#4643	<p>#4643 7040-61D I/O Drawer Attached A #4643 7040-61D I/O Drawer Attached indicates that a 7040-61D I/O Drawer is installed in the 24-inch primary rack of a Model 595. One to four #4643s can be installed. Only AIX and Linux adapters and disk units can be installed in the 7040-61D.</p> <p>Minimum operating system level: i5/OS V5R3 Supported on Model 595. The #4643 is a Customer Install Feature.</p>

#5074	<p>#5074 PCI Expansion Tower</p> <p>The #5074 PCI Expansion Tower is attached to Models 820, 830, and 840 for adding up to 45 disk units (15 are “base”, 30 additional with #5101 or #5111), up to 11 PCI IOAs and up to two removable media units. The #5074 includes #9691 or #2739/#9739 bus adapter to provide the HSL interface to the system, a #9943 Base PCI IOP, space for two removable media devices, one battery backup, and redundant or hot swap power supplies. The #5074 is capable of controlling Ultra2 Small Computer System Interface (SCSI) disk units.</p> <p>Select two (any combination) of the following HSL cables for the first tower on an HSL loop. For additional towers on an HSL loop, select one HSL cable per tower:</p> <ul style="list-style-type: none"> ▶ #1460 - 3m Copper HSL Cable ▶ #1461 - 6m Copper HSL Cable ▶ #1462 - 15m Copper HSL Cable ▶ #1470 - 6m Optical HSL Cable ▶ #1471 - 30m Optical HSL Cable ▶ #1472 - 100m Optical HSL Cable ▶ #1473 - 250m Optical HSL Cable ▶ #1474 - 6m HSL to HSL-2 Cable ▶ #1475 - 10m HSL to HSL-2 Cable <p>For the Model 810, if the #5074 attaches to HSL ports A0 or A1, the HSL cable cannot exceed 6 m. For the Model 820, if the #5074 attaches to HSL port A1 of the system unit, the HSL connection to port A1 cannot exceed 6 m. When a #5074 is present, one #1460 or #1461 must be selected.</p> <p>Select one of the following SPCN cables per tower:</p> <ul style="list-style-type: none"> ▶ #0369 100m Optical SPCN Cable ▶ #1463 - 2m SPCN Cable ▶ #1464 - 6m SPCN Cable ▶ #1465 - 15m SPCN Cable ▶ #1466 - 30m SPCN Cable ▶ #1468 - 250m Optical SPCN Cable <p>One #14xx power cord must be specified (geography dependent). See 11.2, “SPCN (power) cables” on page 382 for power cord options.</p> <p>Maximum: Six on the Model 520, 12 on the Model 550, 30 on the Model 570, 48 on the Model 595, five on the Model 820, 13 on Model 830, and 23 on Model 840, 47 on Model 890</p> <p>The #5074 is also supported in Linux partitions with SUSE Linux Enterprise Server 9 for POWER or Red Hat Enterprise Linux AS for POWER Version 3.</p> <p>Supported on Models 520 (9406 only), 550, 570, 595, 820, 830, 840, and 890.</p> <p>The #5074 is a Customer Install Feature.</p> <p>The #5074 is withdrawn from marketing as of 01 October 2005. A #5094 PCI-X Expansion Tower is the recommended replacement.</p>
-------	---

#5075	<p>#5075 PCI Expansion Tower</p> <p>The #5075 PCI Expansion Tower is attached to a Model 820 for adding up to six disk units and up to seven PCI IOAs. The #5075 includes a 32 MB PCI IOP (CCIN 284B) embedded on its backplane. In a Model 820, the seven PCI IOAs are supported (driven) by the embedded 32 MB PCI IOP and by #2843 PCI IOPs, #2790 PCI Integrated Netfinity® #2790 PCI Integrated Netfinity Server, or #2791/#2792/#2799 PCI Integrated xSeries Servers.</p> <p>The #5075 is capable of controlling Ultra2 SCSI disk units. A #5156 Redundant Power and Cooling feature can be added to provide a redundant power supply and a cooling fan.</p> <p>Select two (any combination) of the following HSL cables for the first tower on the Model 820. For additional towers, select one HSL cable per tower:</p> <ul style="list-style-type: none"> ▶ #1460 - 3m Copper HSL Cable ▶ #1461 - 6m Copper HSL Cable ▶ #1462 - 15m Copper HSL Cable <p>The #1462 is not allowed to attach the #5075 PCI Expansion Tower directly to system port A1 on the Model 270, 800, 810, or 820. When a #5075 is present, one #1460 or #1461 must be selected. For the Model 800, 810, or 820, if the #5075 attaches to HSL ports A0 or A1, the HSL cable cannot exceed 6 m. If the #5075 PCI Expansion Tower is in a clustered loop with a Model 825, 870, or 890, select one #1460 or #1461, and two of the following HSL cables:</p> <ul style="list-style-type: none"> ▶ #1474 - 6m HSL to HSL-2 Cable ▶ #1475 - 10m HSL to HSL-2 Cable <p>Select one of the following SPCN cables per tower:</p> <ul style="list-style-type: none"> ▶ #1463 - 2m SPCN Cable ▶ #1464 - 6m SPCN Cable ▶ #1465 - 15m SPCN Cable ▶ #1466 - 30m SPCN Cable <p>One #14xx power cord must be specified (geography dependent). See 11.2, "SPCN (power) cables" on page 382 for power cord options.</p> <p>Maximum: Five Supported on Models 820, 810, and 825. The #5075 is a Customer Install Feature. The #5075 is withdrawn from marketing as of 21 November 2003.</p>
-------	--

#5078	<p>#5078 PCI Expansion Unit</p> <p>The #5078 PCI Expansion Unit is a “top hat” that installs on top of the #9079 Base I/O Tower and on top of the #5074 PCI Expansion Tower. The #5078 has 14 PCI slots, which allows up to 11 PCI IOAs to be added. The PCI IOAs are supported (driven) by #2843 PCI IOPs, #2790 PCI Integrated Netfinity Server, and #2791/#2792/#2799 PCI Integrated xSeries Servers.</p> <p>Disk units and removable media devices are not supported and cannot be installed in the #5078 PCI Expansion Unit. The #5078 includes a bus adapter to provide the HSL interface to the system. The IBM marketing configurator adds to the order and defaults to copper HSL:</p> <ul style="list-style-type: none"> ▶ #9691 Base Bus Adapter (copper HSL) ▶ #9739 Base Optical Bus Adapter (HSL) <p>The two electrical cables of the #5078 connect to the power source in the #5074/#9079. The #5078 can be ordered with a #5074/#9079 on initial orders and the #5074/#9079 ships with the #5078 installed. The #5078 can also be ordered as an MES install on an existing #5074/#9079.</p> <p>The #5078 can be on the same HSL loop as the #5074/#9079, or it can be on a separate HSL loop from the #5074/#9079. If the #5078 and the #5074/#9079 are on the same HSL loop, then a #1460 - 3m Copper HSL Cable should be included in the order (for both initial orders and for MES orders) to connect the #5078 and the #5074/#9079.</p> <p>If the #5074/#9079 and the #5078 are on separate HSL loops, then one or two of the following HSL cables must be on the order. Select two HSL cables if the #5078 is the first or only expansion tower/unit on an HSL loop. Select one HSL cable if the #5078 coexists with other expansion towers or units on an HSL loop:</p> <ul style="list-style-type: none"> ▶ #1460 - 3m Copper HSL Cable ▶ #1461 - 6m Copper HSL Cable ▶ #1462 - 15m Copper HSL Cable ▶ #1470 - 6m Optical HSL Cable ▶ #1471 - 30m Optical HSL Cable ▶ #1472 - 100m Optical HSL Cable ▶ #1473 - 250m Optical HSL Cable ▶ #1474 - 6m HSL to HSL-2 Cable ▶ #1475 - 10m HSL to HSL-2 Cable <p>Select one of the following SPCN cables per expansion unit:</p> <ul style="list-style-type: none"> ▶ #0369 100m Optical SPCN Cable ▶ #1463 - 2m SPCN Cable ▶ #1464 - 6m SPCN Cable ▶ #1465 - 15m SPCN Cable ▶ #1466 - 30m SPCN Cable ▶ #1468 - 250m Optical SPCN Cable <p>The #1462 cannot be used to connect to HSL port A1 on the Model 820. Requires a #5074 PCI Expansion Tower (1.8 m) or #9079 Base I/O Tower. The #5078 is supported for migration on a #5094 PCI-X Expansion Tower. Supported on Models 810, 820, 825, 830, 840, 870, and 890. Not supported on the #5079 1.8 m I/O Tower. Maximum: One per #5074 PCI Expansion Tower one per #9079 Base I/O Tower The #5078 is not a Customer Install Feature. The #5078 is withdrawn from marketing as of 01 October 2004. A #5088 is the recommended replacement.</p>
-------	---

#5079

#5079 1.8 m I/O Tower (PCI I/O Expansion Tower)

The #5079 1.8 m I/O Tower is attached to Models 820, 830, and 840 for adding up to 90 disk units, up to 22 PCI IOAs, and up to four removable media units. The #5079 includes two (in any combination) #9691 or #9739 optical HSL bus adapters to provide the HSL interface to the system. The #5079 is essentially two #5074 PCI Expansion Tower, stacked in a single 1.8 m tower. Each ordered #5079 counts as two #5074s toward the system model maximums. For each #5079 ordered, a quantity of two #0574 - #5074 Equivalent specify codes are added to the order. The #5079 is capable of controlling Ultra2 SCSI disk units.

Select two, three, or four (any combination) of the following HSL cables for each tower:

- ▶ #1460 - 3m Copper HSL Cable
- ▶ #1461 - 6m Copper HSL Cable
- ▶ #1462 - 15m Copper HSL Cable
- ▶ #1470 - 6m Optical HSL Cable
- ▶ #1471 - 30m Optical HSL Cable
- ▶ #1472 - 100m Optical HSL Cable
- ▶ #1473 - 250m Optical HSL Cable
- ▶ #1474 - 6m HSL to HSL-2 Cable
- ▶ #1475 - 10m HSL to HSL-2 Cable

For the Model 810 and 820, if the #5079 attaches to HSL ports A0 or A1, the HSL cable cannot exceed 6 m. When a #5079 is present, one #1460 or #1461 must be selected.

Select two of the following SPCN cables per tower:

- ▶ #0369 100m Optical SPCN Cable
- ▶ #1463 - 2m SPCN Cable
- ▶ #1464 - 6m SPCN Cable
- ▶ #1465 - 15m SPCN Cable
- ▶ #1466 - 30m SPCN Cable
- ▶ #1468 - 250m Optical SPCN Cable

Two #14xx power cords must be specified (geography dependent). See 11.2, "SPCN (power) cables" on page 382 for power cord options.

Maximum: Two on the Model 810 and 820, nine on the Model 825, six on the Model 830, 11 on the Model 840, and 29 on the Model 870 and 890

The #5079 is also supported in Linux partitions with SUSE Linux Enterprise Server 9 for POWER or Red Hat Enterprise Linux AS for POWER Version 3.

The #5079 is a Customer Install Feature.

The #5079 is withdrawn from marketing as of 01 October 2005. A #5294 PCI-X Expansion Tower is the recommended replacement.

#5088	<p>#5088 PCI-X Expansion Unit</p> <p>The #5088 PCI-X Expansion Unit is an 8 EIA high “top hat”, which can be installed on top of a #5074/#5094 PCI-X Expansion Tower or on top of a #9079/#9094 Base PCI I/O Enclosure. The #5088 has 14 PCI-X slots for installation of PCI IOPs and IOAs. Disk units and removable media are not supported by the #5088 and cannot be installed.</p> <p>The #5088 PCI-X Expansion Unit has two redundant 575W power supplies and two power connector cables that attach internally to the AC box of the tower on which it resides. The #5088 has dual line cord capability, but to achieve it, the tower on which it resides must have dual line cord capability.</p> <p>The #5088 PCI-X Expansion Unit includes a bus adapter to provide the HSL interface to the system. The IBM marketing configurator adds one of the following to the order:</p> <ul style="list-style-type: none"> ▶ #9876 Base Optical Bus Adapter ▶ #9877 - Base HSL-2 Bus Adapter ▶ #9886 Base Optical Bus Adapter <ul style="list-style-type: none"> - Specify when attaching to optical HSL-2 ports. ▶ #9887 Base HSL-2 Bus Adapter (default) <ul style="list-style-type: none"> - Specify when attaching to copper HSL ports. <p>For Models 810 and 820, if the #5088 attaches to HSL ports A0 or A1, the HSL cable cannot exceed 6 m. Select an appropriate number of the following HSL/HSL-2 cables:</p> <ul style="list-style-type: none"> ▶ #1307 -1.75m Copper HSL-2 Cable ▶ #1470 - 6m Optical HSL Cable ▶ #1471 - 30m Optical HSL Cable ▶ #1472 - 100m Optical HSL Cable ▶ #1473 - 250m Optical HSL Cable ▶ #1474 - 6m HSL to HSL-2 Cable ▶ #1475 - 10m HSL to HSL-2 Cable ▶ #1482 - 3.5m HSL-2 Cable ▶ #1483 - 10m HSL-2 Cable ▶ #1485 - 15m HSL-2 Cable <p>Select one of the following SPCN cables per expansion unit:</p> <ul style="list-style-type: none"> ▶ #0369 100m Optical SPCN Cable ▶ #1463 - 2m SPCN Cable ▶ #1464 - 6m SPCN Cable ▶ #1465 - 15m SPCN Cable ▶ #1466 - 30m SPCN Cable ▶ #1468 - 250m Optical SPCN Cable ▶ #6001 Power Control Cable - 2M ▶ #6006 Power Control Cable - 3M ▶ #6007 Power Control Cable - 15M ▶ #6008 Power Control Cable - 6M ▶ #6029 Power Control Cable - 30M <p>The #5088 PCI-X Expansion Unit can be ordered with a #5074 PCI Expansion Tower, #5094 PCI-X Expansion Tower, #9079 Base I/O Tower, and #9094 Base PCI I/O Enclosure on initial orders. The #5074, #5094, #9079, and #9094 ship with the #5088 installed. The #5088 can also be ordered as an MES install on an existing #5074, #5094, #9079, and #9094.</p> <p>A #5088 cannot be installed on a #5294 1.8m I/O Tower or an #8094 Optional 1.8 m I/O Rack. Maximum: One per #5074, #5094, #9079, and #9094</p> <p>The #5088 is also supported in Linux partitions with SUSE Linux Enterprise Server 9 for POWER or Red Hat Enterprise Linux AS for POWER Version 3. Minimum operating system level: OS/400 V5R2 The #5088 is not a Customer Install Feature. The #5088 is withdrawn from marketing as of 01 June 2006.</p>
-------	--

#5094

#5094 PCI-X Expansion Tower

The #5094 PCI-X Expansion Tower is a PCI expansion tower which provides I/O capability for iSeries servers. The #5094 has 15 disk unit slots, with an additional 30 slots available with the #5108 30 Disk Expansion Feature. The #5094 has two removable media slots and 14 PCI-X IOP/IOA card slots.

A #9844 Base PCI IOP is included as base and needs to be listed on an initial order for a #5094 PCI-X Expansion Tower.

The #5094 PCI-X Expansion Tower includes a bus adapter to provide the HSL interface to the system. The IBM marketing configurator adds one of the following to the order:

- ▶ #6417 HSL-2/RIO-G Bus Adapter
- ▶ #9517 Base HSL-2/RIO-G Bus Adapter
 - A #9517 Base HSL-2/RIO-G Bus Adapter is shipped for Models 520, 550, 570, and 595.
- ▶ #9876 Base Optical Bus Adapter
- ▶ #9877 Base HSL-2 Bus Adapter
 - A #9877 Base HSL-2 Bus Adapter is shipped with new orders of a #5094 for Models 800, 810, 820, 825, 830, 840, 870, and 890.
- ▶ #9886 Base Optical Bus Adapter
 - Specify when attaching to optical HSL-2 ports.
- ▶ #9887 Base HSL-2 Bus Adapter (default)
 - Specify when attaching to copper HSL ports.

For Models 810 and 820, if the #5094 attaches to HSL ports A0 or A1, the HSL cannot exceed 6 m.

Select an appropriate number of the following HSL/HSL-2 cables:

- ▶ #1307 -1.75m Copper HSL-2 Cable
- ▶ #1470 - 6m Optical HSL Cable
- ▶ #1471 - 30m Optical HSL Cable
- ▶ #1472 - 100m Optical HSL Cable
- ▶ #1473 - 250m Optical HSL Cable
- ▶ #1474 - 6m HSL to HSL-2 Cable
- ▶ #1475 - 10m HSL to HSL-2 Cable
- ▶ #1482 - 3.5m HSL-2 Cable
- ▶ #1483 - 10m HSL-2 Cable
- ▶ #1485 - 15m HSL-2 Cable

Select one of the following SPCN cables per expansion unit:

- ▶ #0369 100m Optical SPCN Cable
- ▶ #1463 - 2m SPCN Cable
- ▶ #1464 - 6m SPCN Cable
- ▶ #1465 - 15m SPCN Cable
- ▶ #1466 - 30m SPCN Cable
- ▶ #1468 - 250m Optical SPCN Cable
- ▶ #6001 Power Control Cable - 2M
- ▶ #6006 Power Control Cable - 3M
- ▶ #6007 Power Control Cable - 15M
- ▶ #6008 Power Control Cable - 6M
- ▶ #6029 Power Control Cable - 30M

Order #5115 Dual Line Cords Tower on each #5094 PCI-X Expansion Tower required to have dual line cord support. When a #5094 is ordered without #5115, select one line cord from the following list. When a #5094 is ordered with the #5115, select two line cords from the following list:

- ▶ #1408 - 4.3m 200V/16A Power Cord Italy
- ▶ #1409 - 4.3m 200V/16A Power Cord AU/NZ
- ▶ #1418 - 4.3m 200V/16A Power Cord S Africa
- ▶ #1419 - 4.3m 200V/16A Power Cord Israel

<p>#5094 (cont.)</p>	<p>#5094 PCI-X Expansion Tower</p> <ul style="list-style-type: none"> ▶ #1420 - 4.3m 200V/16A Power Cord EU/Asia ▶ #1421 - 4.3m 200V/16A Power Cord CH/DK ▶ #1451 - 200V 6-ft Line Cord ▶ #1452 - 200V 14-ft Line Cord ▶ #1453 - 200V 6-ft Locking Line Cord ▶ #1454 - 200V 12A 14-ft TL Line Cord (U.S. default) ▶ #1455 - 200V 6-ft Watertight Line Cord ▶ #1456 - 200V 14-ft Watertight Line Cord ▶ #1476 - 4.3m 200V/12A Power Cord UK <p>PCI IOAs are supported (driven) by the #9844/#9943 Base PCI IOP, #2843/#2844/#2847 PCI IOPs, #2790 PCI Integrated Netfinity Server, #2791/#2792/#2799 PCI Integrated xSeries Servers or #4710/#9710 Integrated xSeries Servers.</p> <p>The 45 disk unit positions are in groups of 15. Each group of 15 disk units is further divided into three groups of five disk units. Each group of five disk units is supported on a separate SCSI (LVD-SCSI) bus from a #2757, #2780, #4748, or #4778 PCI RAID Disk Unit Controller. Each group of 15 disk units requires one #2757, #4748, or #4778 PCI RAID Disk Unit Controller.</p> <p>The mounting for the first 15 disk units is included in the #5094 (part of the base tower). The mounting for the next 30 disk units is optional by ordering feature code #5108 30-Disk Expansion Feature.</p> <p>The #5094 and #9094 expansion towers offer additional LPAR configuration flexibility. Instead of the previous maximum number of three disk controllers supported in a #5094/#9094, now up to nine total disk controllers are supported. These can be either OS/400 controlled (maximum of six OS/400 partitions) or Linux controlled. The #5294 and #8094 are similarly enhanced and now support a maximum of 18 disk controllers. The #5703/#0628 disk controller can be used to go beyond the maximum of three, already supported #2757, #2780, #4748, and #4778 disk controllers.</p> <p>Each tower must have at least one #2748, #2757, #2780, #4748, or #4778 for each group of 15 disk units in the tower. Only the #5703/#0628 can be ordered as an extra controller (up to two #5703/#0628s per group of 15 disk units in the same tower) if #0143 Disk Controller Placement Exception is also ordered. Disk controllers #2748, #2757, #2780, #4748, or #4778 cannot be ordered as extra controllers if #0143 is also ordered. A maximum of six #5703/#0628s per #5094/#9094 tower are supported.</p> <p>The number of disk units per #2757 and #2780 varies by configuration:</p> <ul style="list-style-type: none"> ▶ Up to 20 disk units per #2757 are supported in a #5094 PCI-X Expansion Tower attached to a Model 520, 550, 570, or 595. ▶ Up to 18 disk units per #2757 are supported in the system unit with System Unit Expansion disk cages of the Model 270, 800, and 810. Up to 15 disk units per #2757 are supported in a #9094 Base PCI I/O Enclosure attached to a Model 870 or 890. <p>The #5094 PCI-X Expansion Tower supports up to two removable media devices (internal tape or internal CD-ROM or DVD). These removable media devices are supported by the same #2757, #2780, #4748, or #4778 PCI RAID Disk Unit Controller which supports the 15 base disk units.</p> <p>The #5094 is also supported in Linux and AIX partitions with SUSE Linux Enterprise Server 9 for POWER or Red Hat Enterprise Linux AS for POWER Version 3, and AIX 5L for POWER V5.2. Minimum operating system level: OS/400 V5R2 The #5094 is a Customer Install Feature. The tower and drawer configurations no longer include a #9844 Base PCI IOP as of 31 January 2006 with the announcement of IOP-less support in IBM System i5 and eServer i5 servers. Refer to "#9844 Inclusion Rules" on page 174.</p>
--------------------------	---

#5095	<p>#5095 PCI-X Expansion Tower</p> <p>The #5095 PCI-X Expansion Tower provides I/O capability for iSeries systems. The #5095 has seven PCI-X IOP/IOA slots. The #5095 also supports up to 12 disk units. A #9844 Base PCI IOP is included as base and should be on an initial order for the #5095 PCI-X Expansion Tower.</p> <p>The #5095 includes a bus adapter to provide the HSL-2 interface to the system. The IBM marketing configurator adds one of the following to the order:</p> <ul style="list-style-type: none">▶ #6417 HSL-2/RIO-G Bus Adapter▶ #9517 Base HSL-2/RIO-G Bus Adapter<ul style="list-style-type: none">– A #9517 Base HSL-2/RIO-G Bus Adapter is shipped for Models 520, 550, 570, and 595.▶ #9876 Base Optical Bus Adapter▶ #9877 Base HSL-2 Bus Adapter<ul style="list-style-type: none">– A #9877 Base HSL-2 Bus Adapter is shipped with new orders of a #5094 for Models 800, 810, 820, 825, 830, 840, 870, and 890.▶ #9886 Base Optical Bus Adapter (optical HSL-2)<ul style="list-style-type: none">- Specify when attaching to optical HSL-2 ports.▶ #9887 Base HSL-2 Bus Adapter (default)<ul style="list-style-type: none">- Specify when attaching to copper HSL ports.
-------	---

#5095
(cont.)

#5095 PCI-X Expansion Tower

For the Model 800 or 810, if the #5095 attaches to HSL ports A0 or A1, the HSL Cable cannot exceed 6 m.

Select an appropriate number of the following HSL/HSL-2 cables:

- ▶ #1307 -1.75m Copper HSL-2 Cable
- ▶ #1470 - 6m Optical HSL Cable
- ▶ #1472 - 100m Optical HSL Cable
- ▶ #1473 - 250m Optical HSL Cable
- ▶ #1474 - 6m HSL to HSL-2 Cable
- ▶ #1475 - 10m HSL to HSL-2 Cable
- ▶ #1482 - 3.5m HSL-2 Cable
- ▶ #1483 - 10m HSL-2 Cable
- ▶ #1485 - 15m HSL-2 Cable

Select one of the following line cords (select two if #5138 Redundant Power and Cooling is selected):

- ▶ #1410 - 200V 6-ft Line Cord
- ▶ #1411 - 200V 14-ft Line Cord
- ▶ #1412 - 125V 6-ft Line Cord (US default)
- ▶ #1414 - 200V 6-ft Locking Line Cord
- ▶ #1415 - 200V 6-ft Watertight Line Cord
- ▶ #1438 - 4.3m 200V/10A Power Cord AU/NZ
- ▶ #1439 - 4.3m 200V/10A Power Cord EU/Asia
- ▶ #1440 - 4.3m 200V/10A Power Cord Denmark
- ▶ #1441 - 4.3m 200V/10A Power Cord S Africa
- ▶ #1442 - 4.3m 200V/10A Power Cord Swiss
- ▶ #1443 - 4.3m 200V/10A Power Cord UK
- ▶ #1444 - 4.3m 200V/10A Power Cord Italy

Select one of the following SPCN cables:

- ▶ #0369 100m Optical SPCN Cable
- ▶ #1463 - 2m SPCN Cable
- ▶ #1464 - 6m SPCN Cable
- ▶ #1465 - 15m SPCN Cable
- ▶ #1466 - 30m SPCN Cable
- ▶ #1468 - 250m Optical SPCN Cable
- ▶ #6001 Power Control Cable - 2M
- ▶ #6006 Power Control Cable - 3M
- ▶ #6007 Power Control Cable - 15M
- ▶ #6008 Power Control Cable - 6M
- ▶ #6029 Power Control Cable - 30M

The #5095 PCI-X Expansion Tower supports seven PCI-X IOA/IOP card slots. One Integrated xSeries Server is supported in slots C1 and C2.

The #5095 PCI-X Expansion Tower has redundant power when #5138 Redundant Power and Cooling is present or ordered. The #5138 includes a second 435W power supply. A second line cord is required with #5138 to provide redundant power support in this tower and also enables dual line cord capability.

If an Integrated xSeries Server is ordered as part of an MES, the #9844 Base PCI IOP (in slot C1) and any associated IOAs must be repositioned within the system.

The #5095 is also supported in Linux and AIX partitions with SUSE Linux Enterprise Server 9 for POWER or Red Hat Enterprise Linux AS for POWER Version 3, and AIX 5L for POWER V5.2.

Minimum operating system level: OS/400 V5R2

The #5095 is a Customer Install Feature.

The tower and drawer configurations longer include a #9844 Base PCI IOP as of 31 January 2006 with the announcement of IOP-less support in IBM System i5 and eServer i5 servers. Refer to "#9844 Inclusion Rules" on page 174.

#5097	<p>#5097 1.8m I/O Tower</p> <p>The #5097 1.8m I/O Tower is an I/O expansion tower that can contain up to 90 disk units. It has 28 PCI slots and four removable media bays. The #5097 is the result of a conversion from an #8093 Optional 1.8 m I/O Rack.</p> <p>Each #5097 is essentially a #5094 PCI-X Expansion Tower (bottom enclosure) and a #5074 PCI Expansion Tower (top enclosure) with side covers and casters removed, placed in a 1.8 M rack. Each #5097 counts as one #5094 and one #5074 towards the system model maximums.</p> <p>Two bus adapters are included with each #5097 to provide the HSL interfaces to the system.</p> <p>Top enclosure (#5074)</p> <ul style="list-style-type: none"> ▶ #9691 Base Bus Adapter for copper HSL interfaces ▶ #9739 Base Optical Bus Adapter for optical HSL interfaces <p>Bottom enclosure (#5094)</p> <ul style="list-style-type: none"> ▶ #9877 - Base HSL-2 Bus Adapter for copper HSL-2 interfaces <p>The upper (#5074) and lower (#5094) enclosures in a #5097 are not connected internally by an HSL cable. If the #5097 is to be placed in an HSL loop (both upper and lower enclosure on same HSL loop), an HSL cable is required to connect the upper and lower enclosures. An HSL loop uses all optical or all copper ports/cables. A copper loop can intermix I/O towers or units with copper HSL and copper HSL-2 ports. Select the appropriate cable based on the type of HSL ports to which it is being attached, and the cable length required.</p> <p>Select three or four (any combination) of the following HSL cables, on the first #5097 on system, initial order. For additional #5097s or on an MES, select two, three or four (any combination) HSL cables per tower:</p> <ul style="list-style-type: none"> ▶ #1307 1.75m Copper HSL-2 Cable ▶ #1308 -2.5m Copper HSL-2 Cable ▶ #1460 - 3m Copper HSL Cable ▶ #1461 - 6m Copper HSL Cable ▶ #1462 - 15m Copper HSL Cable ▶ #1464 - 6m SPCN Cable ▶ #1470 - 6m Optical HSL Cable ▶ #1471 - 30m Optical HSL Cable ▶ #1472 - 100m Optical HSL Cable ▶ #1473 - 250m Optical HSL Cable ▶ #1475 - 10m HSL to HSL-2 Cable ▶ #1481 - 1m HSL-2 Cable ▶ #1482 - 3.5m HSL-2 Cable ▶ #1483 - 10m HSL-2 Cable <p>Select two of the following SPCN cables for each #5097:</p> <ul style="list-style-type: none"> ▶ #0369 100m Optical SPCN Cable ▶ #1463 - 2m SPCN Cable ▶ #1464 - 6m SPCN Cable ▶ #1465 - 15m SPCN Cable ▶ #1466 - 30m SPCN Cable ▶ #1468 - 250m Optical SPCN Cable ▶ #6001 Power Control Cable - 2M ▶ #6006 Power Control Cable - 3M ▶ #6007 Power Control Cable - 15M ▶ #6008 Power Control Cable - 6M ▶ #6029 Power Control Cable - 30M <p>Each #5097 includes two PCI IOPs. Process a Record Purposes Only (RPO) for each #5097 to add a quantity of one #0694 - #5094 Equivalent and one #0574 - #5074 Equivalent to the attaching system.</p> <p>Each of the two tower units within a #5097 fully supports 45 disk units. A #5101 or #5108 is not required.</p> <p>Dual line cord capability is available for the #5079 with #5105 Dual Line Cords I/O Tower (top enclosure) and #5114 Dual Line Cords Tower (bottom enclosure). With #5105 and #5114 installed, both tower units of a #5097 have dual line cord capability. Order two additional line cords (for a total of four) when a #5105 and #5114 is installed.</p>
-------	---

<p>#5097 (cont.)</p>	<p>#5097 1.8m I/O Tower</p> <p>The following line cords are supported on a #5097 (two line cord features required):</p> <ul style="list-style-type: none"> ▶ #1396 - 4.3m 200V/16A Power Cord China ▶ #1399 - 4.3m 300V/16A ▶ #1406 - 200V 16A 14-ft TL Line Cord ▶ #1408 - 4.3m 200V/16A Power Cd Italy ▶ #1409 - 4.3m 200V/16A Power Cd AU/NZ ▶ #1418 - 4.3m 200V/16A Power Cd S Africa ▶ #1419 - 4.3m 200V/16A Power Cd Israel ▶ #1420 - 4.3m 200V/16A Power Cd EU/Asia ▶ #1421 - 4.3m 200V/16A Power Cd CH/DK ▶ #1451 - 200V 6-ft Line Cord ▶ #1452 - 200V 14-ft Line Cord ▶ #1453 - 200V 6-ft Locking Line Cord ▶ #1454 - 200V 12A 14-ft TL Line Cord ▶ #1455 - 200V 6-ft Watertight Line Cord ▶ #1456 - 200V 14-ft Watertight Line Cord ▶ #1457 - 200V 6-ft Upper Line Cord ▶ #1458 - 200V 6-ft Upper Locking Cord ▶ #1459 - 200V 6-ft Upper Watertight Cord ▶ #1476 - 4.3m 200V/12A Power Cd UK <p>The 45 disk unit positions in each unit of a #5097 are in groups of 15. Each group of 15 disk units is further divided into three groups of five disk units. Each group of five disk units is supported on a separate SCSI bus from a PCI Disk Unit Controller.</p> <p>The #5715 and #5703 controllers are not supported in the upper unit of a #5097.</p> <p>The two removable media bays of each unit within a #5097 are supported by the same PCI Disk Unit Controller which supports disk unit positions D31 through D35 of each internal tower unit.</p> <p>HSL connections, two to four wall electrical outlets, one #0574 and one #0694 are required.</p> <p>The #5097 is only available as a MES to the #8093 during an upgrade to an eServer i5 server.</p> <p>Minimum operating system level: i5/OS V5R3 Supported on Models 570 and 595. The #5097 is not a Customer Install Feature. The #5097 is withdrawn from marketing for new orders only on 01 October 2005.</p>
<p>#5101</p>	<p>#5101 30 Disk Unit Expansion</p> <p>The #5101 30 Disk Unit Expansion is a disk unit expansion enclosure feature for the #5074 PCI Expansion Tower, the #9074 Base I/O Tower, and the #9074/#9079 Base I/O Tower. The #5101 includes two 15-disk unit enclosures, one 765-watt power supply, backplanes, and cables. One #2757, #2780, #4748, or #4778 PCI RAID Disk Unit Controller is required to support one 15-disk unit enclosure.</p> <p>Supported on Models 520 (9406 only), 550, 570, 595, 810, 820, 825, 830, 840, 870, and 890.</p> <p>The #5101 is not a Customer Install Feature.</p>
<p>#5107</p>	<p>#5107 30 Disk Expansion</p> <p>The #5107 30 Disk Expansion is a disk unit expansion enclosure feature for the #9094 Base PCI I/O Enclosure. In the #8093 Optional 1.8 m I/O Rack/#8094 Optional 1.8 m I/O Rack, 30 disk expansions are installed in the bottom and upper units with no feature code required. The #5107 includes two 15-disk unit enclosures, one 765-watt power supply, backplanes, and cables. One #2757, #2780, #4748, or #4778 PCI RAID Disk Unit Controller is required to support the 15 disk units in each of the two disk unit enclosures included with #5107.</p> <p>Minimum operating system level: OS/400 V5R2 The #5107 is not a Customer Install Feature. The #5107 is withdrawn from marketing as of 01 June 2006.</p>
<p>#5108</p>	<p>#5108 30 Disk Expansion Feature</p> <p>The #5108 30 Disk Expansion Feature is a disk unit expansion enclosure feature for a #5094 PCI-X Expansion Tower. The #5108 includes two 15-disk unit enclosures, one power supply, backplanes and cables. One #2757, #2780, #4748, or #4778 PCI RAID Disk Unit Controller is required to support each 15-disk unit enclosure.</p> <p>Minimum operating system level: OS/400 V5R2 The #5108 is not a Customer Install Feature.</p>

#5111	<p>#5111 30 Disk Expansion with Dual Line Cords</p> <p>The #5111 30 Disk Expansion with Dual Line Cords is a disk unit expansion enclosure feature for systems and towers that are dual line cord enabled. (Model 830 system units have #5103, Model 840 system units have #5104 and #5074 PCI Expansion Tower which have #5105.) The #5111 includes two 15-disk unit enclosures, backplanes and cables. One #4748/#4778 PCI RAID Disk Unit Controller is required to support one 15-disk unit enclosure.</p> <p>A #5103 is required when ordered for a Model 830 system unit, a #5104 is required when ordered for an 840 system unit, and a #5105 when ordered for a stand-alone #5074 PCI Expansion Tower or top unit in an #8079 Optional Base 1.8 m I/O Rack.</p> <p>The #5111 is not a Customer Install Feature.</p>
#5114	<p>#5114 Dual Line Cords Tower</p> <p>The #5114 Dual Line Cords Tower provides dual line cord capability for the #9094 Base PCI I/O Enclosure and the lower unit in an #8093 Optional 1.8 m I/O Rack/#8094 Optional 1.8 m I/O Rack. Two #14xx line cords must be ordered on an initial order or a model upgrade into an 890 from a non-890 model. When ordering a #5114 as an MES, one 840W power supply is shipped and one additional #14xx line cord is required to be ordered. See 11.2, "SPCN (power) cables" on page 382 for power cord options.</p> <p>The #5114 has country-specific or region-specific usage.</p> <p>Minimum operating system level: OS/400 V5R2</p> <p>The #5114 is not a Customer Install Feature.</p> <p>The #5114 is withdrawn from marketing as of 01 June 2006.</p>
#5117	<p>#5117 30 Disk Expansion with Dual Line Cords</p> <p>The #5117 30 Disk Expansion with Dual Line Cords is a disk unit expansion enclosure feature for a dual line cord enabled #9094 Base PCI I/O Enclosure. The #5117 includes two 15 disk unit enclosures, back planes and cables. One #2757 PCI-X Ultra RAID Disk Controller, #2780 PCI-X Ultra4 RAID Disk Controller, #4748 PCI RAID Disk Unit Controller, or #4778 PCI RAID Disk Unit Controller is required to support the 15 disk units in each of the two disk unit enclosures included with the #5117.</p> <p>Minimum operating system level: OS/400 V5R2</p> <p>The #5117 is not a Customer Install Feature.</p> <p>Supported on Models 870 and 890.</p>
#5138	<p>#5138 Redundant Power and Cooling</p> <p>The #5138 Redundant Power and Cooling provides redundant power for the #0595/#5095 PCI-X Expansion Tower. A #5138 consists of a 435W power supply and additional cooling fans. A second line cord is required on each #0595/#5095 with a #5138 installed. The #5138, together with the second line cord, enables dual line cord capability for an #0595/#5095.</p> <p>Maximum: One per #0595/#5095 PCI-X Expansion Tower</p> <p>Minimum operating system level: OS/400 V5R2</p> <p>The #5138 is a Customer Install Feature.</p>
#5156	<p>#5156 Redundant Power and Cooling</p> <p>The #5156 Redundant Power and Cooling adds an additional 575-watt power supply for redundancy and additional cooling fan to the #5075 PCI Expansion Tower.</p> <p>Marketing configurator defaults to a #5156 on a Model 820 for any added #5075 when the system unit contains a #5155 575-watt power supply. If a #5155 is ordered as an MES to an existing Model 820, default one #5156 for each #5075 present or ordered. The #5156s are not mandatory and can be removed from an order.</p> <p>Supported on Models 810, 820, and 825</p> <p>The #5156 is a Customer Install Feature.</p> <p>The #5156 is withdrawn from marketing as of 01 June 2006.</p>
#5158	<p>#5158 850W AC Power Supply</p> <p>The #5158 is an optional 850W power supply which provides redundant power for the Model 520 system unit. A second line cord is required.</p> <p>Supported on Model 520.</p> <p>The #5158 is a Customer Install Feature.</p>
#5159	<p>#5159 850 Watt Power Supply</p> <p>The #5159 provides an optional 850W power supply which installs in a 520 system unit with processor #8325, #8327 or #8330 and provides redundant power.</p> <p>The #5159 requires an additional system unit line cord feature to be ordered.</p> <p>Minimum operating system level: i5/OS V5R3 with V5R3M5 LIC, AIX 5L for POWER V5.2 for IBM eServer, Red Hat Enterprise Linux AS for POWER Version 3, SUSE Linux Enterprise Server 9 for POWER</p> <p>Supported on Model 520+.</p> <p>The #5159 is a Customer Install Feature.</p>

#5168	<p>#5168 30 Disk Expansion for #9194 Tower</p> <p>The #5168 30 Disk Expansion for #9194 Tower is a unit expansion enclosure feature for the #9194 Base PCI-X Expansion Tower. The #5168 includes two 15-disk-unit enclosures, one power supply, back-planes and cables. A minimum of one disk unit controller is required to support each of the two 15-disk-unit enclosures included with #5168.</p> <p>Minimum operating system level: i5/OS V5R3</p> <p>Supported on Model 595 #9194 towers.</p> <p>The #5168 is an IBM Customer Service Representative setup feature.</p>
#5294	<p>#5294 1.8m I/O Tower</p> <p>The #5294 1.8m I/O Tower has space for 90 disk units, has 28 PCI-X IOP/IOA slots, and has four removable media bays. The #5294 is equivalent to two #5094 PCI-X Expansion Towers, with covers and casters removed and positioned in a 1.8m rack. It includes two bus adapters to provide the HSL interface to the system. The IBM marketing configurator adds two, in any combination, of the following to the order:</p> <ul style="list-style-type: none"> ▶ #6417 HSL-2/RIO-G Bus Adapter ▶ #9517 Base HSL-2/RIO-G Bus Adapter A #9517 Base HSL-2/RIO-G Bus Adapter is shipped for Models 520, 550, 570, and 595. ▶ #9876 Base Optical Bus Adapter ▶ #9877 Base HSL-2 Bus Adapter A #9877 Base HSL-2 Bus Adapter is shipped with new orders of a #5294 for Models 800, 810, 820, 825, 830, 840, 870, and 890. ▶ #9886 Base Optical Bus Adapter (optical HSL-2) Specify when attaching to optical HSL-2 ports. ▶ #9887 Base HSL-2 Bus Adapter (default) Specify when attaching to copper HSL ports. <p>The #5094 PCI-X Expansion Tower is the default when a PCI IOP or IOA is ordered that requires a PCI expansion unit. The #5294 can be specified on the IBM marketing configurator's extra controllers screen. For each #5294 ordered, two #0694 - #5094 Equivalent specify codes are added to the order. If a #5294 is to be shared between two systems, process an RPO to remove one #0694 from the original ordering system and add it to the sharing system.</p> <p>The upper and lower enclosures (#5094 PCI-X Expansion Tower) in the #5294 are not connected internally by an HSL cable. Two to four of the following HSL/HSL-2 cables are required:</p> <ul style="list-style-type: none"> ▶ #1307 -1.75m Copper HSL-2 Cable ▶ #1470 - 6m Optical HSL Cable ▶ #1471 - 30m Optical HSL Cable ▶ #1472 - 100m Optical HSL Cable ▶ #1473 - 250m Optical HSL Cable ▶ #1474 - 6m HSL to HSL-2 Cable ▶ #1475 - 10m HSL to HSL-2 Cable ▶ #1482 - 3.5m HSL-2 Cable ▶ #1483 - 10m HSL-2 Cable ▶ #1485 - 15m HSL-2 Cable <p>For the Model 810, if the #5294 attaches to HSL ports A0 or A1, the HSL cable cannot exceed 6 m. For the Model 820, the HSL cable connection to port A1 cannot exceed 6 m.</p>

<p>#5294 (cont.)</p>	<p>#5294 1.8m I/O Tower</p> <p>Two #9844 Base PCI IOPs are included with each #5294 1.8m I/O Tower. The IBM marketing configurator allows a #5294 to exist in the field without any #9844s present, but all ordered #5294s ship with two #9844s. The #5294 1.8m I/O Tower is capable of controlling Ultra4 (u320) SCSI disk units.</p> <p>If no #5116 Dual Line Cords - #5294 is installed, select two line cords from the following list. If one #5116 Dual Line Cords - #5294 is installed, select three line cords from the following list. If two #5116 Dual Line Cords - #5294 are installed, select four line cords from the following list:</p> <ul style="list-style-type: none"> ▶ #1451 - 200V 6-ft Line Cord ▶ #1452 - 200V 14-ft Line Cord ▶ #1453 - 200V 6-ft Locking Line Cord ▶ #1454 - 200V 12A 14-ft TL Line Cord (default) ▶ #1455 - 200V 6-ft Watertight Line Cord ▶ #1456 - 200V 14-ft Watertight Line Cord ▶ #1457 - 200V 6-ft Upper Line Cord ▶ #1458 - 200V 6-ft Upper Locking Cord ▶ #1459 - 200V 6-ft Upper Watertight Cord <p>Select two of the following SPCN cables per tower:</p> <ul style="list-style-type: none"> ▶ #0369 - 100m Optical SPCN Cable (825, 830, 840, 870, 890) ▶ #1463 - 2m SPCN Cable (270, 800, 810, 820, 825, 830, 840, 870, 890) ▶ #1464 - 6m SPCN Cable (270, 800, 810, 820, 825, 830, 840, 870, 890) ▶ #1465 - 15m SPCN Cable (270, 800, 810, 820, 825, 830, 840, 870, 890) ▶ #1466 - 30m SPCN Cable (270, 800, 810, 820, 825, 830, 840, 870, 890) ▶ #1468 - 250m Optical SPCN Cable (825, 830, 840, 870, 890) ▶ #6001 Power Control Cable - 2M ▶ #6006 Power Control Cable - 3M ▶ #6007 Power Control Cable - 15M ▶ #6008 Power Control Cable - 6M ▶ #6029 Power Control Cable - 30M <p>The 90 disk unit positions are in groups of 15. Each group of 15 disk units is further divided into three groups of five disk units. Each group of five disk units is supported on a separate SCSI bus from a #2757, #2780, #4748, or #4778 PCI RAID Disk Unit Controller. Each group of 15 disk units requires one #2757, #2780, #4748, or #4778 PCI RAID Disk Unit Controller.</p> <p>The #5294 1.8m I/O Tower supports up to four removable media devices (internal tape or CD-ROM or DVD). These removable media devices are supported by the two #2757, #2780, #4748, or #4778 PCI RAID Disk Unit Controllers which support the first two groups of 15 disk units.</p> <p>The #5294 and #8094 expansion towers offer additional LPAR configuration flexibility. Instead of the previous maximum number of six disk controllers supported in a #5294/#8094, now up to eighteen total disk controllers are supported. These can be either OS/400 controlled (maximum of six OS/400 partitions) or Linux controlled. The #5703/#0628 disk controller can be used to go beyond the maximum of three, already supported #2757, #2780, #4748, and #4778 disk controllers per top or bottom unit of the #5294/#8094.</p> <p>Each tower must have at least one #2748, #2757, #2780, #4748, or #4778 for each group of 15 disk units in the tower. Only the #5703/#0628 can be ordered as an extra controller (up to two #5703/#0628s per group of 15 disk units in the same tower) if #0143 Disk Controller Placement Exception is also ordered. The #2748, #2757, #2780, #4748, or #4778 disk controllers cannot be ordered as extra controllers if #0143 is also ordered.</p> <p>The number of disk units per #2757 and #2780 varies by configuration: Up to 20 disk units per #2757 are supported in a #5094 PCI-X Expansion Tower attached to a Model 520, 550, 570, or 595. Up to 18 disk units per #2757 are supported in the system unit with System Unit Expansion disk cages of the Model 270, 800, and 810. Up to 15 disk units per #2757 are supported in a #9094 Base PCI I/O Enclosure attached to a Model 870 or 890.</p> <p>The #5294 1.8m I/O Tower reports to the system as two CCIN 5094. Each ordered #5294 counts as two #5094s toward the system model maximums.</p> <p>Minimum operating system level: OS/400 V5R2 Supported in Linux and AIX partitions with SUSE Linux Enterprise Server 9 for POWER or Red Hat Enterprise Linux AS for POWER Version 3, and AIX 5L for POWER V5.2. The #5294 is a Customer Install Feature. The tower and drawer configurations longer include a #9844 Base PCI IOP as of 31 January 2006 with the announcement of IOP-less support in System i5 and eServer i5 servers. Refer to "#9844 Inclusion Rules" on page 174.</p>
--------------------------	---

#5554	<p>#5554 Mirror 35 GB Disk/Controller Package</p> <p>The #5554 provides a disk unit controller (#2780 PCI-X Ultra4 RAID Disk Controller equivalent) and twelve 15k rpm 35 GB disk units (#4326 35.16 GB 15k RPM Disk Unit equivalent) for servers doing mirroring. Either #0042 Mirrored System IOP Level or #0043 Mirrored System Bus Level is required.</p> <p>Minimum operating system level: i5/OS V5R3, SUSE Linux Enterprise Server 9 for POWER or Red Hat Enterprise Linux AS for POWER Version 3, AIX 5L for POWER V5.2 Supported on Models 520, 550, 570, 595, 800, 810, 820, 825, 830, 840, 870, 890, and 9411-100. The #5554 is a Customer Install Feature.</p> <p>The #5554 is withdrawn from marketing as of 25 October 2005. The #5555 Mirror 70 GB Disk/Controller Package or #2780 PCI-X Ultra4 RAID Disk Controller plus a quantity of 12 of #4326 35.16 GB 15k RPM Disk Unit are the recommended replacements.</p>
#5555	<p>#5555 Mirror 70 GB Disk/Controller Package</p> <p>The #5555 provides a disk unit controller (#2780 PCI-X Ultra4 RAID Disk Controller equivalent) and twelve 15k rpm 70 GB disk units (#4327 70.56 GB 15k RPM Disk Unit equivalent) for servers doing mirroring. Either #0042 Mirrored System IOP Level or #0043 Mirrored System Bus Level is required.</p> <p>Minimum operating system level: i5/OS V5R3, SUSE Linux Enterprise Server 9 for POWER or Red Hat Enterprise Linux AS for POWER Version 3, AIX 5L for POWER, V5.2 for iSeries Supported on Models 520, 550, 570, 595, 800, 810, 820, 825, 830, 840 870, 890, and 9411-100. The #5555 is a Customer Install Feature.</p>
#5556	<p>#5556 - Mirror 141.12 GB Disk/Controller Package</p> <p>The #5556 provides a disk unit controller (#2780 PCI-X Ultra4 RAID Disk Controller equivalent) and twelve 15k rpm 141.12 GB disk units (#4328 141.12 GB 15k RPM Disk Unit equivalent) for servers doing mirroring. Either #0042 Mirrored System IOP Level or #0043 Mirrored System Bus Level is required.</p> <p>Minimum operating system level: i5/OS V5R3, SUSE Linux Enterprise Server 9 for POWER or Red Hat Enterprise Linux AS for POWER Version 3, AIX 5L for POWER, V5.2 for iSeries Supported on Models 520, 550, 570, 595. The #5556 is a Customer Install Feature.</p>

#5560

#5560 - Mirror 35 GB Drawer Package

The #5560 package feature includes one #0595 rack mount I/O expansion unit, one #9844 IOP, twelve #4326 35.16 GB 15k rpm disk units and two high-function, large write cache disk controllers (#2757 or newer) for servers doing mirroring. The I/O drawer requires five EIA of rack space and has a total of seven PCI-X IOP/IOA slots and 12 disk unit slots. Three PCI-X slots and 12 disk unit slots are filled with the package contents, but four PCI-X slots can be used by other PCI-X IOPs/IOAs.

On IBM ordering, shipping, and inventory documentation, the component features specifically for the #0595 I/O drawer, the disk units, and the disk controllers are not shown. The chargeable #5560 feature number is shown and carries the price and warranty for this package.

Use the specific component features such as #0595 for all planning and implementation documentation.
Requires the #0040 Mirrored System Disk Level.

A bus adapter to provide the HSL interface to the system is required. Select one of the following:

- ▶ #9517 — Base HSL-2 Bus Adapter, to specify two copper HSL-2 ports
- ▶ #9876 — Base Optical Bus Adapter, to specify two optical HSL ports

One or two HSL cables must be ordered with each #5560. When ordering cables to connect to the HSL interface, optical HSL, copper HSL, copper HSL-2, or copper HSL to HSL-2 cables are required. An HSL loop uses all optical or all copper ports/cables. A copper loop can intermix I/O towers/units with copper HSL and copper HSL-2 ports. Select the appropriate cable based on the type of HSL ports to which it is being attached, and the cable length required.

The following HSL cables can be used with a #5560:

Copper HSL to HSL-2 (HSL on one end and HSL-2 on the other end)

- ▶ #1474 6m HSL to HSL-2 Cable
- ▶ #1475 10m HSL to HSL-2 Cable
- ▶ #1487 3m HSL to HSL-2 Cable

Copper HSL-2 (HSL-2 on both ends of the cable)

- ▶ #1307 1.75m HSL-2 Cable
- ▶ #1308 2.5m HSL-2 Cable
- ▶ #1481 1.2m HSL-2 Cable
- ▶ #1482 3.5m HSL-2 Cable
- ▶ #1483 10m HSL-2 Cable
- ▶ #1485 15m HSL-2 Cable

Optical HSL (optical HSL connections on both ends of the cable)

- ▶ #1470 6m HSL Optical Cable
- ▶ #1471 30m HSL Optical Cable
- ▶ #1472 100m HSL Optical Cable
- ▶ #1473 250m HSL Optical Cable

One SPCN cable is required with each #5560. Select one of the following:

- ▶ #1463 2m SPCN Cable
- ▶ #1464 6m SPCN Cable
- ▶ #1465 15m SPCN Cable
- ▶ #1466 30m SPCN Cable
- ▶ #0369 100m Optical SPCN Cable
- ▶ #1468 250m Optical SPCN Cable
- ▶ #6001 2m SPCN Cable
- ▶ #6006 3m SPCN Cable
- ▶ #6007 15m SPCN Cable
- ▶ #6008 6m SPCN Cable
- ▶ #6029 30m SPCN Cable

The #5560 has redundant power when feature #5138 is installed. The #5138 provides a second 435W power supply. In addition, when a #5138 is installed, a second line cord must be ordered. The presence of the #5138 and the second line cord, enables dual line cord capability.

Select one of the following line cords, or select two if #5138 is ordered:

- ▶ #1394 4.3m 200V/10A Power Cord Brazil
- ▶ #1395 4.3m 200V/10A Power Cd China
- ▶ #1397 4.3m 200V/10A Power Cord Argent
- ▶ #1398 4.3m 100V/10A Power Cord Brazil
- ▶ #1410 200V 6-ft Line Cord

#5560
(cont.)

#5560 - Mirror 35 GB Drawer Package

- ▶ #1411 — 200V 14-ft Line Cord
- ▶ #1412 — 125V 6-ft Line Cord
- ▶ #1413 — 125V 14-ft Line Cord
- ▶ #1414 — 200V 6-ft Locking Line Cord
- ▶ #1415 — 200V 6-ft Watertight Line Cord
- ▶ #1416 — 200V 14-ft Locking Line Cord
- ▶ #1417 — 200V 14-ft Watertight Line Cord
- ▶ #1422 — 3m IEC 320 C13/14 PDU Cord
- ▶ #1438 — 4.3m 200V/10A Pwr Cd AU/NZ
- ▶ #1439 — 4.3m 200V/10A Pwr Cd EU/Asia
- ▶ #1440 — 4.3m 200V/10A Pwr Cd Denmark
- ▶ #1441 — 4.3m 200V/10A Pwr Cd S Africa
- ▶ #1442 — 4.3m 200V/10A Pwr Cd Swiss
- ▶ #1443 — 4.3m 200V/10A Pwr Cd UK
- ▶ #1444 — 4.3m 200V/10A Pwr Cd Italy
- ▶ #1445 — 4.3m 200V/10A Pwr Cd Israel
- ▶ #6458 — 14-ft Int 250V/10A Pwr Cd
- ▶ #6460 — 14-ft 125V/15A Power Cord
- ▶ #6469 — 14-ft 250V/15A Power Cord
- ▶ #6470 — 6-ft 125V/15A Power Cord
- ▶ #6471 — 9-ft 125V/15A Power Cord
- ▶ #6472 — 9-ft 250V/16A Power Cord
- ▶ #6473 — 9-ft 250V/10A Power Cord
- ▶ #6474 — 9-ft 250V/13A Power Cord
- ▶ #6475 — 9-ft 250V/16A Power Cord
- ▶ #6476 — 9-ft 250V/10A Power Cord
- ▶ #6477 — 9-ft 250V/10A Power Cord
- ▶ #6478 — 9-ft 250V/16A Power Cord
- ▶ #6479 — 9-ft 250V/10A Power Cord
- ▶ #6487 — 6-ft 250V/15A Power Cord
- ▶ #6488 — 9-ft Dual Voltage Pwr Cd
- ▶ #6493 — 9-ft 250V/10A Power Cord
- ▶ #6494 — 9-ft 250V/10A Power Cord
- ▶ #6495 — 9-ft 250V/10A Power Cord
- ▶ #6496 — 9-ft 250V/10A Power Cord
- ▶ #6497 — 6-ft 250V/15A Power Cord
- ▶ #6498 — 6-ft 250V/15A Power Cord
- ▶ #6651 — 9-ft 127V/15A Power Cord
- ▶ #6659 — 9-ft 240V/15A Power Cord
- ▶ #6660 — 14-ft 127V/15A Power Cord
- ▶ #6669 — 14-ft 240V/15A Power Cord
- ▶ #6670 — 6-ft 125V/15A Power Cord
- ▶ #6680 — 9-ft 250V/10A Power Cord
- ▶ #6687 — 6-ft 250V/15A Power Cord

Supported on Models 520, 550, 570, 595, and 9411-100.
The #5560 is a Customer Install Feature.

#5561

#5561 - Mirror 70 GB Drawer Package

The #5561 package feature includes one #0595 rack mount I/O expansion unit, one #9844 IOP, twelve #4327 70.56 GB 15k rpm disk units and two high-function, large write cache disk controllers (#2757 or newer) for servers doing mirroring. The I/O drawer requires five EIA of rack space and has a total of seven PCI-X IOP/IOA slots and 12 disk unit slots. Three PCI-X slots and 12 disk unit slots are filled with the package contents, but four PCI-X slots can be used by other PCI-X IOPs/IOAs.

On IBM ordering, shipping, and inventory documentation, the component features specifically for the #0595 I/O drawer, the disk units, and the disk controllers are not shown. The chargeable #5561 feature number is shown and carries the price and warranty for this package.

Use the specific component features such as #0595 for all planning and implementation documentation.

The #0040 Mirrored System Disk Level is required.

A bus adapter to provide the HSL interface to the system is required. Select one of the following:

- ▶ #9517 — Base HSL-2 Bus Adapter, to specify two copper HSL-2 ports
- ▶ #9876 — Base Optical Bus Adapter, to specify two optical HSL ports

One or two HSL cables must be ordered with each #5561. When ordering cables to connect to the HSL interface, optical HSL, copper HSL, copper HSL-2, or copper HSL to HSL-2 cables are required. An HSL loop uses all optical or all copper ports/cables. A copper loop can intermix I/O towers/units with copper HSL and copper HSL-2 ports. Select the appropriate cable based on the type of HSL ports to which it is being attached, and the cable length required.

The following HSL cables can be used with a #5561:

Copper HSL to HSL-2 (HSL on one end and HSL-2 on the other end)

- ▶ #1474 6m HSL to HSL-2 Cable
- ▶ #1475 10m HSL to HSL-2 Cable
- ▶ #1487 3m HSL to HSL-2 Cable

Copper HSL-2 (HSL-2 on both ends of the cable)

- ▶ #1307 1.75m HSL-2 Cable
- ▶ #1308 2.5m HSL-2 Cable
- ▶ #1481 1.2m HSL-2 Cable
- ▶ #1482 3.5m HSL-2 Cable
- ▶ #1483 10m HSL-2 Cable
- ▶ #1485 15m HSL-2 Cable

Optical HSL (optical HSL connections on both ends of the cable)

- ▶ #1470 6m HSL Optical Cable
- ▶ #1471 30m HSL Optical Cable
- ▶ #1472 100m HSL Optical Cable
- ▶ #1473 250m HSL Optical Cable

One SPCN cable is required with each #5561. Select one of the following:

- ▶ #1463 2m SPCN Cable
- ▶ #1464 6m SPCN Cable
- ▶ #1465 15m SPCN Cable
- ▶ #1466 30m SPCN Cable
- ▶ #0369 100m Optical SPCN Cable
- ▶ #1468 250m Optical SPCN Cable
- ▶ #6001 2m SPCN Cable
- ▶ #6006 3m SPCN Cable
- ▶ #6007 15m SPCN Cable
- ▶ #6008 6m SPCN Cable
- ▶ #6029 30m SPCN Cable

The #5561 has redundant power when feature #5138 is installed. The #5138 provides a second 435W power supply. In addition, when a #5138 is installed, a second line cord must be ordered. The presence of the #5138 and the second line cord, enables dual line cord capability.

Select one of the following line cords, or select two if #5138 is ordered:

- ▶ #1394 - 4.3m 200V/10A Power Cord Brazil
- ▶ #1395 - 4.3m 200V/10A Power Cd China
- ▶ #1397 - 4.3m 200V/10A Power Cord Argent
- ▶ #1398 - 4.3m 100V/10A Power Cord Brazil

#5561
(cont.)

#5561 - Mirror 70 GB Drawer Package

- ▶ #1410 - 200V 6-ft Line Cord
- ▶ #1411 - 200V 14-ft Line Cord
- ▶ #1412 - 125V 6-ft Line Cord
- ▶ #1413 - 125V 14-ft Line Cord
- ▶ #1414 - 200V 6-ft Locking Line Cord
- ▶ #1415 - 200V 6-ft Watertight Line Cord
- ▶ #1416 - 200V 14-ft Locking Line Cord
- ▶ #1417 - 200V 14-ft Watertight Line
- ▶ #1422 - 3m IEC 320 C13/14 PDU Cord
- ▶ #1438 - 4.3m 200V/10A Power Cd AU/NZ
- ▶ #1439 - 4.3m 200V/10A Power Cd EU/Asia
- ▶ #1440 - 4.3m 200V/10A Power Cd Denmark
- ▶ #1441 - 4.3m 200V/10A Power Cd S Africa
- ▶ #1442 - 4.3m 200V/10A Power Cd Swiss
- ▶ #1443 - 4.3m 200V/10A Power Cd UK
- ▶ #1444 - 4.3m 200V/10A Power Cd Italy
- ▶ #1445 - 4.3m 200V/10A Power Cd Israel
- ▶ #6458 - 14-ft Int 250V/10A Power Cd
- ▶ #6460 - 14-ft 125V/15A Power Cord
- ▶ #6469 - 14-ft 250V/15A Power Cord
- ▶ #6470 - 6-ft 125V/15A Power Cord
- ▶ #6471 - 9-ft 125V/15A Power Cord
- ▶ #6472 - 9-ft 250V/16A Power Cord
- ▶ #6473 - 9-ft 250V/10A Power Cord
- ▶ #6474 - 9-ft 250V/13A Power Cord
- ▶ #6475 - 9-ft 250V/16A Power Cord
- ▶ #6476 - 9-ft 250V/10A Power Cord
- ▶ #6477 - 9-ft 250V/10A Power Cord
- ▶ #6478 - 9-ft 250V/16A Power Cord
- ▶ #6479 - 9-ft 250V/10A Power Cord
- ▶ #6487 - 6-ft 250V/15A Power Cord
- ▶ #6488 - 9-ft Dual Voltage Power Cd
- ▶ #6493 - 9-ft 250V/10A Power Cord
- ▶ #6494 - 9-ft 250V/10A Power Cord
- ▶ #6495 - 9-ft 250V/10A Power Cord
- ▶ #6496 - 9-ft 250V/10A Power Cord
- ▶ #6497 - 6-ft 250V/15A Power Cord
- ▶ #6498 - 6-ft 250V/15A Power Cord
- ▶ #6651 - 9-ft 127V/15A Power Cord
- ▶ #6659 - 9-ft 240V/15A Power Cord
- ▶ #6660 - 14-ft 127V/15A Power Cord
- ▶ #6669 - 14-ft 240V/15A Power Cord
- ▶ #6670 - 6-ft 125V/15A Power Cord
- ▶ #6680 - 9-ft 250V/10A Power Cord
- ▶ #6687 - 6-ft 250V/15A Power Cord

Supported on Models 520, 550, 570, 595, and 9411-100
The #5561 is a Customer Install Feature.

#5562

#5562 - Mirror 35 GB Tower Package

The #5562 package feature includes one #5095 tower, one #9844 IOP, twelve #4326 35.16 GB 15k rpm disk units and two high-function, large write cache disk controllers (#2757 or newer) for servers doing mirroring. The #5095 has a total of seven PCI-X IOP/IOA slots and 12 disk unit slots. Three PCI-X slots and 12 disk unit slots are filled with the package contents, but four PCI-X slots can be used by other PCI-X IOPs/IOAs.

On IBM ordering, shipping, and inventory documentation, the component features specifically for the #5095 tower, the disk units, and the disk controllers is not shown. The chargeable feature #5562 is shown and carries the price and warranty for this package.

Use the specific component features such as #5095 for all planning and implementation documentation. The #0040 Mirrored System Disk Level is required.

A bus adapter to provide the HSL interface to the system is required. Select one of the following:

- ▶ #9517 — Base HSL-2 Bus Adapter, to specify two copper HSL-2 ports
- ▶ #9876 — Base Optical Bus Adapter, to specify two optical HSL ports

One or two HSL cables must be ordered with each #5562. When ordering cables to connect to the HSL interface, optical HSL, copper HSL, copper HSL-2, or copper HSL to HSL-2 cables are required. An HSL loop uses all optical or all copper ports/cables. A copper loop can intermix I/O towers/units with copper HSL and copper HSL-2 ports. Select the appropriate cable based on the type of HSL ports to which it is being attached, and the cable length required.

The following HSL cables can be used with a #5562:

- ▶ Copper HSL to HSL-2 (HSL on one end and HSL-2 on the other end)
 - #1474 6m HSL to HSL-2 Cable
 - #1475 10m HSL to HSL-2 Cable
 - #1487 3m HSL to HSL-2 Cable
- ▶ Copper HSL-2 (HSL-2 on both ends of the cable)
 - #1307 1.75m HSL-2 Cable
 - #1308 2.5m HSL-2 Cable
 - #1481 1.2m HSL-2 Cable
 - #1482 3.5m HSL-2 Cable
 - #1483 10m HSL-2 Cable
 - #1485 15m HSL-2 Cable
- ▶ Optical HSL (optical HSL connections on both ends of the cable)
 - #1470 6m HSL Optical Cable
 - #1471 30m HSL Optical Cable
 - #1472 100m HSL Optical Cable
 - #1473 250m HSL Optical Cable
- ▶ One SPCN cable is required with each #5562. Select one of the following:
 - #1463 2m SPCN Cable
 - #1464 6m SPCN Cable
 - #1465 15m SPCN Cable
 - #1466 30m SPCN Cable
 - #0369 100m Optical SPCN Cable
 - #1468 250m Optical SPCN Cable
 - #6001 2m SPCN Cable
 - #6006 3m SPCN Cable
 - #6007 15m SPCN Cable
 - #6008 6m SPCN Cable
 - #6029 30m SPCN Cable

The #5562 has redundant power when feature #5138 is installed. The #5138 provides a second 435W power supply. In addition, when a #5138 is installed, a second line cord must be ordered. The presence of the #5138 and the second line cord, enables dual line cord capability.

Select one of the following line cords, or select two if #5138 is ordered:

- ▶ #1394 — 4.3m 200V/10A Pwr Crd Brazil
- ▶ #1395 — 4.3m 200V/10A Pwr Cd China
- ▶ #1397 — 4.3m 200V/10A Pwr Crd Argent
- ▶ #1398 — 4.3m 100V/10A Pwr Crd Brazil
- ▶ #1410 — 200V 6-ft Line Cord

#5562
(cont.)

#5562- Mirror 35 GB Tower Package

- ▶ #1411 — 200V 14-ft Line Cord
- ▶ #1412 — 125V 6-ft Line Cord
- ▶ #1413 — 125V 14-ft Line Cord
- ▶ #1414 — 200V 6-ft Locking Line Cord
- ▶ #1415 — 200V 6-ft Watertight Line Cord
- ▶ #1416 — 200V 14-ft Locking Line Cord
- ▶ #1417 — 200V 14-ft Watertight Line Cord
- ▶ #1422 — 3m IEC 320 C13/14 PDU Cord
- ▶ #1438 — 4.3m 200V/10A Pwr Cd AU/NZ
- ▶ #1439 — 4.3m 200V/10A Pwr Cd EU/Asia
- ▶ #1440 — 4.3m 200V/10A Pwr Cd Denmark
- ▶ #1441 — 4.3m 200V/10A Pwr Cd S Africa
- ▶ #1442 — 4.3m 200V/10A Pwr Cd Swiss
- ▶ #1443 — 4.3m 200V/10A Pwr Cd UK
- ▶ #1444 — 4.3m 200V/10A Pwr Cd Italy
- ▶ #1445 — 4.3m 200V/10A Pwr Cd Israel
- ▶ #6458 — 14-ft Int 250V/10A Pwr Cd
- ▶ #6460 — 14-ft 125V/15A Power Cord
- ▶ #6469 — 14-ft 250V/15A Power Cord
- ▶ #6470 — 6-ft 125V/15A Power Cord
- ▶ #6471 — 9-ft 125V/15A Power Cord
- ▶ #6472 — 9-ft 250V/16A Power Cord
- ▶ #6473 — 9-ft 250V/10A Power Cord
- ▶ #6474 — 9-ft 250V/13A Power Cord
- ▶ #6475 — 9-ft 250V/16A Power Cord
- ▶ #6476 — 9-ft 250V/10A Power Cord
- ▶ #6477 — 9-ft 250V/10A Power Cord
- ▶ #6478 — 9-ft 250V/16A Power Cord
- ▶ #6479 — 9-ft 250V/10A Power Cord
- ▶ #6487 — 6-ft 250V/15A Power Cord
- ▶ #6488 — 9-ft Dual Voltage Pwr Cd
- ▶ #6493 — 9-ft 250V/10A Power Cord
- ▶ #6494 — 9-ft 250V/10A Power Cord
- ▶ #6495 — 9-ft 250V/10A Power Cord
- ▶ #6496 — 9-ft 250V/10A Power Cord
- ▶ #6497 — 6-ft 250V/15A Power Cord
- ▶ #6498 — 6-ft 250V/15A Power Cord
- ▶ #6651 — 9-ft 127V/15A Power Cord
- ▶ #6659 — 9-ft 240V/15A Power Cord
- ▶ #6660 — 14-ft 127V/15A Power Cord
- ▶ #6669 — 14-ft 240V/15A Power Cord
- ▶ #6670 — 6-ft 125V/15A Power Cord
- ▶ #6680 — 9-ft 250V/10A Power Cord
- ▶ #6687 — 6-ft 250V/15A Power Cord

Supported on Models 520 550, 570, 595, and 9411-100
The #5562 is a Customer Install Feature.

#5563

#5563 - Mirror 70 GB Tower Package

The #5563 package feature includes one #0595 rack mount I/O expansion unit, one #9844 IOP, twelve #4327 70.56 GB 15k rpm disk units and two high-function, large write cache disk controllers (#2757 or newer) for servers doing mirroring. The I/O drawer requires five EIA of rack space and has a total of seven PCI-X IOP/IOA slots and 12 disk unit slots. Three PCI-X slots and 12 disk unit slots are filled with the package contents, but four PCI-X slots can be used by other PCI-X IOPs/IOAs.

On IBM ordering, shipping, and inventory documentation, component features specified for the #0595 I/O drawer, disk units, and disk controllers are not shown. The chargeable #5563 feature number is shown and carries the price and warranty for this package.

Use specific component features, such as #0595, for all planning and implementation documentation.

The #0040 Mirrored System Disk Level is required.

A bus adapter to provide the HSL interface to the system is required. Select one of the following:

- ▶ #9517 — Base HSL-2 Bus Adapter, to specify two copper HSL-2 ports
- ▶ #9876 — Base Optical Bus Adapter, to specify two optical HSL ports

One or two HSL cables must be ordered with each #5563. When ordering cables to connect to the HSL interface, optical HSL, copper HSL, copper HSL-2, or copper HSL to HSL-2 cables are required. An HSL loop uses all optical or all copper ports/cables. A copper loop can intermix I/O towers/units with copper HSL and copper HSL-2 ports. Select the appropriate cable based on the type of HSL ports to which it is being attached, and the cable length required.

The following HSL cables can be used with a #5563:

- ▶ Copper HSL to HSL-2 (HSL on one end and HSL-2 on the other end)
 - #1474 6m HSL to HSL-2 Cable
 - #1475 10m HSL to HSL-2 Cable
 - #1487 3m HSL to HSL-2 Cable
- ▶ Copper HSL-2 (HSL-2 on both ends of the cable)
 - #1307 1.75m HSL-2 Cable
 - #1308 2.5m HSL-2 Cable
 - #1481 1.2m HSL-2 Cable
 - #1482 3.5m HSL-2 Cable
 - #1483 10m HSL-2 Cable
 - #1485 15m HSL-2 Cable
- ▶ Optical HSL (optical HSL connections on both ends of the cable)
 - #1470 6m HSL Optical Cable
 - #1471 30m HSL Optical Cable
 - #1472 100m HSL Optical Cable
 - #1473 250m HSL Optical Cable
- ▶ One SPCN cable is required with each #5563. Select one of the following:
 - #1463 2m SPCN Cable
 - #1464 6m SPCN Cable
 - #1465 15m SPCN Cable
 - #1466 30m SPCN Cable
 - #0369 100m Optical SPCN Cable
 - #1468 250m Optical SPCN Cable
 - #6001 2m SPCN Cable
 - #6006 3m SPCN Cable
 - #6007 15m SPCN Cable
 - #6008 6m SPCN Cable
 - #6029 30m SPCN Cable

The #5563 has redundant power when feature #5138 is installed. The #5138 provides a second 435W power supply. In addition, when a #5138 is installed, a second line cord must be ordered. The presence of the #5138 and the second line cord, enables dual line cord capability.

Select one of the following line cords, or select two if #5138 is ordered:

- ▶ #1394 — 4.3m 200V/10A Pwr Crd Brazil
- ▶ #1395 — 4.3m 200V/10A Pwr Cd China
- ▶ #1397 — 4.3m 200V/10A Pwr Crd Argent
- ▶ #1398 — 4.3m 100V/10A Power Cord Brazil

<p>#5563 (cont.)</p>	<p>#5563- Mirror 70 GB Tower Package</p> <ul style="list-style-type: none"> ▶ #1410 — 200V 6-ft Line Cord ▶ #1411 — 200V 14-ft Line Cord ▶ #1412 — 125V 6-ft Line Cord ▶ #1413 — 125V 14-ft Line Cord ▶ #1414 — 200V 6-ft Locking Line Cord ▶ #1415 — 200V 6-ft Watertight Line Cord ▶ #1416 — 200V 14-ft Locking Line Cord ▶ #1417 — 200V 14-ft Watertight Line ▶ #1422 — 3m IEC 320 C13/14 PDU Cord ▶ #1438 — 4.3m 200V/10A Pwr Cd AU/NZ ▶ #1439 — 4.3m 200V/10A Pwr Cd EU/Asia ▶ #1440 — 4.3m 200V/10A Pwr Cd Denmark ▶ #1441 — 4.3m 200V/10A Pwr Cd S Africa ▶ #1442 — 4.3m 200V/10A Pwr Cd Swiss ▶ #1443 — 4.3m 200V/10A Pwr Cd UK ▶ #1444 — 4.3m 200V/10A Pwr Cd Italy ▶ #1445 — 4.3m 200V/10A Pwr Cd Israel ▶ #6458 — 14-ft Int 250V/10A Pwr Cd ▶ #6460 — 14-ft 125V/15A Power Cord ▶ #6469 — 14-ft 250V/15A Power Cord ▶ #6470 — 6-ft 125V/15A Power Cord ▶ #6471 — 9-ft 125V/15A Power Cord ▶ #6472 — 9-ft 250V/16A Power Cord ▶ #6473 — 9-ft 250V/10A Power Cord ▶ #6474 — 9-ft 250V/13A Power Cord ▶ #6475 — 9-ft 250V/16A Power Cord ▶ #6476 — 9-ft 250V/10A Power Cord ▶ #6477 — 9-ft 250V/10A Power Cord ▶ #6478 — 9-ft 250V/16A Power Cord ▶ #6479 — 9-ft 250V/10A Power Cord ▶ #6487 — 6-ft 250V/15A Power Cord ▶ #6488 — 9-ft Dual Voltage Pwr Cd ▶ #6493 — 9-ft 250V/10A Power Cord ▶ #6494 — 9-ft 250V/10A Power Cord ▶ #6495 — 9-ft 250V/10A Power Cord ▶ #6496 — 9-ft 250V/10A Power Cord ▶ #6497 — 6-ft 250V/15A Power Cord ▶ #6498 — 6-ft 250V/15A Power Cord ▶ #6651 — 9-ft 127V/15A Power Cord ▶ #6659 — 9-ft 240V/15A Power Cord ▶ #6660 — 14-ft 127V/15A Power Cord ▶ #6669 — 14-ft 240V/15A Power Cord ▶ #6670 — 6-ft 125V/15A Power Cord ▶ #6680 — 9-ft 250V/10A Power Cord ▶ #6687 — 6-ft 250V/15A Power Cord <p>Supported on Models 520, 550, 570, 595, and 9411-100 The #5563 is a Customer Install Feature.</p>
<p>#5723</p>	<p>#5723 2-Port Async EIA -232 PCI IOA</p> <p>The #5723 provides connection for two asynchronous EIA-232 devices. Ports are programmable to support EIA-232 protocols at a line speed of 128 Kbps. Provides two asynchronous ports. Occupies one PCI slot. Minimum operating system level: AIX 5L for POWER, OS/400 V5R2 for iSeries Supported on Models 520, 550, 570, and 595. The #5723 is a Customer Install Feature.</p>

#5790

#5790 PCI Expansion Drawer

The #5790 mounts in a 19-inch rack using a #7307 Dual I/O Unit Enclosure or a #7311 Dual I/O Unit Enclosure. Two #5790 drawers can be mounted side by side in a single #7307 or #7311 and are not required to be attached to the same system. The #5790 is a four EIA unit I/O expansion drawer that can accommodate six full-length 64bit PCI-X-blind swap I/O adapters and is attached to the system using a RIO/HSL bus. The #5790 comes standard with two redundant power supplies, and dual power cords, thus providing for redundant concurrently maintainable power and cooling and the blind swap PCI mechanism allows for PCI card servicing without removing the I/O expansion drawer. A PDU in the rack is optional.

The #5790 includes a #9531 Base HSL-2 Bus Adapter to provide the HSL-2 interface to the system. The IBM marketing configurator adds #9531 Base HSL-2 Bus Adapter to the order.

Select an appropriate number of the following HSL/HSL-2 cables:

- ▶ #1474 - 6m HSL to HSL-2 Cable
- ▶ #1475 - 10m HSL to HSL-2 Cable
- ▶ #1307 - 1.75m HSL-2 Cable (Not supported in rack-mounted Model 520 or 550 system unit.)
- ▶ #1308 - 2.5m HSL-2 Cable
- ▶ #1481 - 1.2m HSL-2 Cable (Not supported in rack-mounted Model 520 or 550 system unit.)
- ▶ #1481 - 1m HSL-2 Cable
- ▶ #1482 - 4m HSL-2 Cable
- ▶ #1483 - 10m HSL-2 Cable

Two of the following line cords must be ordered for use with each #5790:

- ▶ #6451 - 14-ft 250V/10A Right Angle Power Cord
- ▶ #6452- 14-ft 250V/10A Right Angle Power Cord
- ▶ #6453- 14-ft 250V/10A Right Angle Power Cord
- ▶ #6454- 14-ft 250V/10A Right Angle Power Cord
- ▶ #6455- 14-ft 250V/10A Right Angle Power Cord
- ▶ #6456- 14-ft 200-240V/12A Right Angle Power Cord
- ▶ #6459 - 12-ft 250V/10A, Right Angle, Drawer to IBM PDU
- ▶ #6461 - 14-ft 250V/10A Right Angle Power Cord
- ▶ #6462- 14-ft 250V/10A Right Angle Power Cord
- ▶ #6463 - 14-ft 250V/10A Right Angle Power Cord
- ▶ #6464 - 14-ft 250V/10A Right Angle Power Cord
- ▶ #6465 14-ft 250V/10A Right Angle Power Cord
- ▶ #6466 14-ft 250V/10A Right Angle Power Cord
- ▶ #6467 14-ft 250V/10A Right Angle Power Cord
- ▶ #6468 14-ft 250V/10A Right Angle Power Cord
- ▶ #6470 - 6-ft 125V/15A Line Cord United States/Canada
- ▶ #6471 - 9-ft 125V/15A Line Cord Brazil
- ▶ #6472 - 9-ft 250V/10A Line Cord EU/Asia
- ▶ #6473 - 9-ft 250V/10A Line Cord Denmark
- ▶ #6474 - 9-ft 250V/10A Line Cord UK
- ▶ #6475 - 9-ft 250V/10A Line Cord Israel
- ▶ #6476 - 9-ft 250V/10A Line Cord Switzerland
- ▶ #6477 - 9-ft 250V/10A Line Cord South Africa/Pakistan
- ▶ #6478 - 9-ft 250V/10A Line Cord Italy/Chile
- ▶ #6479 - 9-ft 250V/10A Line Cord Australia/NZ/Argentina
- ▶ #6487 - 6-ft 250V/15A Line Cord Thailand
- ▶ #6488 - 9-ft 125V/15A or 250V/10A Uruguay/Brazil
- ▶ #6493 - 9-ft 250V/10A Line Cord China
- ▶ #6494 - 9-ft 250V/10A Line Cord India
- ▶ #6496 - 9-ft 250V/10A Line Cord Korea
- ▶ #6497 - 6-ft 250V/15A Line Cord non-IBM PDU
- ▶ #6498 - 6-ft 250V/15A Line Cord non-IBM PDU
- ▶ #6499 14-ft 250V/10A Right Angle Power Cord
- ▶ #6651 - 9-ft 127V/15A Power Cord
- ▶ #6659 - 9-ft 240V/15A Power Cord
- ▶ #6660 - 14-ft 127V/15A Power Cord

<p>#5790, (cont.)</p>	<p>#5790 PCI Expansion Drawer, cont.</p> <ul style="list-style-type: none"> ▶ #6662 - 14-ft 240V/15A Power Cord ▶ #6663 - 14-ft 240V/15A Power Cord ▶ #6669 - 14-ft 240V/15A Power Cord ▶ #6670 - 6-ft125V/15A Power Cord ▶ #6680 - 9-ft 250V/10A Power Cord ▶ #6681 14-ft 200-240V/10A Right Angle Power Cord ▶ #6690 14-ft 200-240V/15A Power Cord ▶ #6691 14-ft 200-240V/12A Power Cord ▶ #6692 14-ft 200-240V/10A Power Cord ▶ #6029 - 30m SPCN Cable <p>Select an appropriate number of the following SPCN cables for use with a #5790:</p> <ul style="list-style-type: none"> ▶ #0369 - 100m Optical SPCN Cable (Not supported on Model 520.) ▶ #1468 - 250m Optical SPCN Cable (Not supported on Model 520.) ▶ #6001 - 2m SPCN Cable (Not supported in rack-mounted Model 520 or 550 system unit.) ▶ #6006 - 3m SPCN Cable ▶ #6008 - 6m SPCN Cable ▶ #6007 - 15m SPCN Cable ▶ #6029 - 30m SPCN Cable <p>Minimum operating system level: i5/OS V5R3 Supported on Models 520, 550, 570, and 595. The #5790 is a Customer Install Feature.</p>
<p>#6069</p>	<p>#6069 Optional Front Door for 2.0m Rack The #6069 provides an black full height rack door on the #0553 iSeries 2.0m Rack. The door is steel, with a perforated flat front surface. Optional feature is a #6580 Optional Rack Security Kit. Requires an #0553 2.0m Rack. Initial order or MES The #6069 is a Customer Install Feature.</p>
<p>#6122</p>	<p>#6122 UPIC Cable Primary Rack EIA 05 The #6122 feature provides redundant power cabling for an I/O drawer with the bottom of the drawer positioned at the 5U location of the 24-inch primary system rack. Supported on Model 595 The #6122 is an IBM Customer Service Representative setup feature.</p>
<p>#6186</p>	<p>#6186 Bulk Power Regulator The #6186 Bulk Power Regulator provides increments of power for use by the systems components such as fans, system unit components, and I/O drawers. Initial order or MES Supported on Model 595 The #6186 is an IBM Customer Service Representative setup feature.</p>
<p>#6247</p>	<p>#6247 2.0m Rack Trim Kit The #6247 provides a trim kit for the front of a #0553 2.0m Rack. Initial order or MES The #6247 is a Customer Install Feature.</p>
<p>#6248</p>	<p>#6248 1.8m Rack Acoustic Doors The #6248 provides front and rear doors for use with the #0551 iSeries Rack. This door kit provides additional acoustic dampening for use where a quieter environment is desired. The #6248 results in a larger footprint and requires additional space. Initial order or MES The #6248 is a Customer Install Feature.</p>
<p>#6249</p>	<p>#6249 2.0m Rack Acoustic Doors The #6249 provides front and rear doors for use with the #0553 iSeries 2.0m Rack. This door kit provides additional acoustic dampening for use where a quieter environment is desired. The #6249 results in a larger footprint and requires additional space. Initial order or MES The #6249 is a Customer Install Feature.</p>

#6251	<p>#6251 Slimline Doors - Primary Rack</p> <p>The #6251 provides front and rear doors for use with the Model 595 24-inch primary rack. This slimline door kit provides a minimized footprint for use where conservation of space is desired.</p> <p>Initial order or MES Supported on Model 595. The #6251 is an IBM Customer Service Representative setup feature.</p>
#6252	<p>#6252 Acoustic Doors - Primary Rack</p> <p>The #6252 provides front and rear doors for use with the Model 595 24-inch primary rack. This door kit provides additional acoustic dampening for use where a quieter environment is desired. The #6252 results in a larger footprint and requires additional space.</p> <p>Initial order or MES Supported on Model 595. The #6252 is an IBM Customer Service Representative setup feature.</p>
#6417	<p>#6417 HSL-2/RIO-G Bus Adapter</p> <p>The #6417 HSL-2/RIO-G Bus Adapter allows existing optical HSL/RIO connected towers the option of switching to copper HSL-2/RIO-G connectivity. The #6417 provides copper HSL-2/RIO-G connectivity for the #5094, #5095/#0595, #5295, #8094 PCI-X Expansion Towers and units.</p> <p>Minimum operating system level: i5/OS V5R3 Supported on Models 520, 550, 570, and 595. The #6417 is a Customer Install Feature.</p>
#6460	<p>#6460 - 14-ft 125V/15A Power Cord</p> <p>The #6460 is a 14-foot 125V/15A power cord that distributes power from a wall outlet to a system unit. #6460 has a type 4 plug and an IEC320 C13 connector.</p> <p>Supported on Model 520 and 9411-100. The #6460 is a Customer Install Feature.</p>
#6574	<p>#6574 - 4-Disk Slot Expansion Base Controller</p> <p>The #6574 - 4-Disk Slot Expansion Base Controller is a feature disk cage that can contain up to four disks (10k and 15k rpm only). The #6574 enables the second set of four disk unit slots in the system unit to be used. The disks in the #6574 are driven by the integrated base SCSI disk controller with or without a #5709 or #5727 write cache. Disk unit hot-plugging is allowed.</p> <p>Minimum operating system level: i5/OS V5R3 Supported on Model 520. The #6574 is a Customer Install Feature.</p>
#6584	<p>#6584 4 Disk Slot Exp - PCI-X Controller</p> <p>The #6584 - 4-Disk Slot Expansion is a disk backplane feature for the system unit, which enables the second four disk slots for use by a separate disk controller plugged into a system unit PCI slot. Disk units plugged into the #6584 are controlled by either a #5703 PCI-X RAID Disk Unit Controller or #5715 PCI-X Tape/DASD Controller.</p> <p>A #6584 can be used for obtaining disk mirroring protection with other drives in the system or for enabling these drives in another system partition.</p> <p>The #6584 is not usable by either the embedded system unit disk controller or by a #5709 RAID Enabler Card</p> <p>Supported on 9406 Model 520 The #6584 is a Customer Install Feature. The #6584 is withdrawn from marketing as of 19 November 2004.</p>
#6585	<p>#6585 - DASD Locking Kit</p> <p>The #6585 provides a locking mechanism that secures up to four disk units in the Model 520. Two #6585 kits are required to secure all eight available disk units in the Model 520. When #6585 is installed and secured with a user-provided padlock, the disk units cannot be removed easily.</p> <p>Supported only on Model 520. The #6585 is a Customer Install Feature.</p>
#6586	<p>#6586 Modem Tray for 19-Inch Rack</p> <p>The #6586 Modem Tray for 19-Inch Rack provides hardware for installing one or two modems in a 19-inch rack. The modem tray occupies 1U of rack space when it is mounted in the front of the rack. It provides a secure location in the rack for external modems such as the ones attached to the Hardware Management Console. It is not a shelf.</p> <p>Required: 19-inch rack with 1U rack space available Supported in #0551, #0553, #0554, #0555 Racks, and on Models 520, 550, 570, 595, 520+, 550+, 570+, and 595 1.9 GHz. The #6586 is a Customer Install Feature.</p>

#6587	<p>#6587 Model 520 Rear Cover</p> <p>The #6587 is a decorative rear cover which has sound deadening capability. The #6587 cover is for Model 520 deskside servers which do not have external I/O attached to an HSL loop. The cover cannot be used if HSL cables are attached to the Model 520 server.</p> <p>Minimum operating system level: i5/OS V5R3</p> <p>Supported on Model 520 configurations with #7885 520 Deskside specify code.</p> <p>The #6587 is a Customer Install Feature.</p>
#6592	<p>#6592 - 4 - Disk Slot Expansion - Base Controller</p> <p>The #6592 is a disk backplane feature that enables the second set of four disk unit slots in the system to be used. Disk units plugged into the #6592 are controlled by the integrated base controller with or without a #5709 or #5727 write cache.</p> <p>Supported on Models 550 and 550+.</p> <p>The #6592 is a Customer Install Feature.</p>
#6593	<p>#6593 - 4 - Disk Slot Expansion. - PCI -X Controller</p> <p>The #6593 - 4-Disk Slot Expansion PCI-X Controller is a disk backplane feature for the Model 550 system unit which enables the second four disk slots for use by a separate disk controller plugged into a system unit PCI slot. Disk units plugged into the #6593 are controlled by another disk controller such as a #5703, #5715, #5736, #5737, #5775, #5776, #0647, or #0648. The #6593 is not usable by the integrated system unit disk controller with or without its #5709/#5727 write cache.</p> <p>A #6593 can be used for obtaining disk mirroring protection with other drives in the system or for enabling these drives in another system partition. Installation of a #6593 can enable a second RAID enabled partition with the system unit itself.</p> <p>Supported on Models 550 and 550+.</p> <p>The #6593 is a Customer Install Feature.</p>
#6594	<p>#6594 - 4-Disk Slot Expansion PCI-X Controller</p> <p>The #6594- 4-Disk Slot Expansion PCI-X Controller is a disk backplane feature for a system unit which enables the second four disk slots for use by a separate disk controller plugged into a system unit PCI slot. Installation of a #6594 allows a #5703 to be plugged in card slot 4 of the 520 system unit, enabling a second RAID enabled partition within the system unit itself. Disk units plugged into the #6594 are controlled by another disk controller such as a #5715, #5736, #5737, #5775, #5776, #0647, or #0648. The #6594 is not usable by the embedded system unit disk controller with or without its #5709 or #5727 write cache.</p> <p>A #6594 can be used for obtaining disk mirroring protection with other drives in the system or for enabling these drives in another system partition. Installation of a #6594 can also enable a second RAID enabled partition within the system unit itself.</p> <p>The #5703 disk controller can control the #6594 disk units with the 1.5 and 1.65 GHz Model 520.</p> <p>Minimum operating system level: i5/OS V5R3</p> <p>Supported on Models 520 and 520+.</p> <p>The #6594 is a Customer Install Feature.</p>
#6580	<p>#6580 Optional Rack Security Kit</p> <p>The #6580 Optional Rack Security Kit provides hardware that can be added to a rack to prevent unauthorized access. It includes keyed front and rear locks for the standard door latches. It also includes two sliding bars that mount inside the left and right rack side panels. The sliding bars are accessible when the rack rear door is open. They can be moved to a position that disables the external latches on the rack side panels, and prevents removal of the side panels.</p> <p>Requires a #0551 iSeries Rack or #0553 2.0m Rack.</p> <p>Supported on Models 520, 550, 570, 595, 800, 810, 825, 870, and 890.</p> <p>The #6580 is a Customer Install Feature.</p>
#6598	<p>#6598 Disk Slot Filler</p> <p>The #6598 Disk Slot Filler provides disk slot covers to install in disk slots which are emptied after the system unit is shipped from IBM. Four disk slot filler covers are shipped with each #6598.</p> <p>All disk bays should be filled with either disk drives or slot fillers when the system unit ships from IBM. If a disk is removed, IBM recommends direct access storage device (DASD) bay slots are refilled with another disk drive or a disk slot filler. A populated DASD bay maintains EMI compliance standards and helps ensure optimal thermal performance.</p> <p>Supported on Models 520, 550, 570, 595, and 9411-100.</p> <p>The #6598 is a Customer Install Feature.</p>

#6863	<p>#6863 System i5 Slim-Line Doors The #6863 - System i5 Slim-Line Doors provides front and rear doors for use with the Model 595 24-inch primary rack. This slimline door kit provides a minimized footprint for use where conservation of space is desired. #6863 is functionally equivalent to #6251, but has the System i5 name and accent color. Supported on Model 595. The #6863 is a Customer Install Feature.</p>
#6864	<p>#6864 System i5 Acoustic Doors The #6864 - System i5 Acoustic Doors provides front and rear doors for use with the Model 595 24-inch primary rack. This door kit provides additional acoustic dampening for use where a quieter environment is desired. #6864 results in a larger footprint and requires additional floor space. The #6864 is functionally equivalent to a #6252, but has the System i5 name and accent color. Supported on Model 595. The #6864 is a Customer Install Feature.</p>
#7002	<p>#7002 HSL Enabler The #7002 HSL Enabler is a required feature on Model 800 processors when attaching an expansion tower or unit, or the external Integrated xSeries Servers. Supported on Model 800. The #7002 is a Customer Install Feature. The #7002 is withdrawn from marketing as of 01 June 2006.</p>
#7116	<p>#7116 System Unit Expansion The #7116 System Unit Expansion allows up to an additional 12 disk units to be added to the Models 800 and 810. The #7116 has no PCI card slots and no removable media slots. The #7116 comes standard with support for six disk units, and requires a #7136 DASD Expansion Unit - 6 slot when installing more than six disk units. The #7116 disk units are driven by disk unit controllers located in the system unit. One of the following line cords must be ordered with the #7116 System Unit Expansion:</p> <ul style="list-style-type: none"> ▶ #1410 - 200V 6-ft Line Cord ▶ #1411 - 200V 14-ft Line Cord ▶ #1412 - 125V 6-ft Line Cord (U.S. default) ▶ #1414 - 200V 6-ft Locking Line Cord ▶ #1415 - 200V 6-ft Watertight Line Cord ▶ #1422 - 3m IEC 320 C13/C14 PDU Cord ▶ #1438 - 4.3m 200V/10A Power Cord AU/NZ ▶ #1439 - 4.3m 200V/10A Power Cord EU/Asia ▶ #1440 - 4.3m 200V/10A Power Cord Denmark ▶ #1441 - 4.3m 200V/10A Power Cord S Africa ▶ #1442 - 4.3m 200V/10A Power Cord Swiss ▶ #1443 - 4.3m 200V/10A Power Cord UK ▶ #1444 - 4.3m 200V/10A Power Cord Italy ▶ #1445 - 4.3m 200V/10A Power Cord Israel <p>The #7116 System Unit Expansion does not attach to the HSL interface. Requires a #7137 DASD Concurrent Maintenance Cage for the #2463 Model 800 processor. Supported on Models 800 and 810. The #7116 is a Customer Install Feature. The #7116 is withdrawn from marketing as of 01 June 2006.</p>
#7124	<p>#7124 DASD Expansion Unit - 5 slot The #7124 DASD Expansion Unit - 5 slot is a 5-pack DASD cage for the Model 825 system unit. The #7124 Includes the DASD cage, DASD backplane and associated SCSI cables. Maximum: Two Supported on Model 825. The #7124 is a Customer Install Feature. The #7124 is withdrawn from marketing as of 01 June 2006.</p>
#7136	<p>#7136 DASD Expansion Unit - 6 slot The #7136 DASD Expansion Unit - 6 slot is a concurrent maintenance DASD expansion feature which is ordered to support the second set of six disk units in a #7116 System Unit Expansion on the Models 800 and 810. Supported on Models 800 and 810. The #7136 is a Customer Install Feature. The #7136 is withdrawn from marketing as of 01 June 2006.</p>

#7137	<p>#7137 DASD Concurrent Maintenance Cage</p> <p>The #7137 DASD Concurrent Maintenance Cage is a six unit DASD expansion feature for the #2463 Model 800 processor. It replaces the base six unit DASD cage, and enables disk unit concurrent maintenance. The #7137 provides a higher speed interface for disk devices, more than double the bandwidth of the base DASD cage. The #7137 is recommended for 15k rpm disk drives.</p> <p>The #7137 is required if a #2757 PCI-X Ultra RAID Disk Controller or an #2780 PCI-X Ultra4 RAID Disk Controller is used or a #7116 System Unit Expansion is installed.</p> <p>When upgrading a #2463 Model 800 processor, process an RPO to remove the #7137 on the installed system.</p> <p>The #2464 Model 800 includes a concurrent maintenance disk unit cage as part of the base system offering.</p> <p>The #7137 is not a Customer Install Feature.</p> <p>The #7137 is withdrawn from marketing as of 01 June 2006.</p>
#7180	<p>#7180 Acoustic Front Door</p> <p>The #7180 provides a front door which has acoustic dampening capabilities for the Model 520 deskside system. #7180 is functionally equivalent to #7753 Acoustic Front Door, but has the System i5 name and accent color.</p> <p>Supported on deskside 520+ models.</p> <p>The #7180 is a Customer Install Feature.</p>
#7181	<p>#7181 Easy-Access Front Cover</p> <p>The #7181 provides a front cover which has an easy access bezel for the deskside Model 520. #7180 is functionally equivalent to #7750 Easy-Access Front Cover, but has the System i5 name.</p> <p>Supported on deskside 520+ models.</p> <p>The #7181 is a Customer Install Feature.</p>
#7182	<p>#7182 520 Rack Mount</p> <p>The #7182 indicates this is a rack-mounted system unit. The system ships with IBM mounting rails for installation in an IBM standard 19-inch rack. Rails are fixed at a 28 inch depth. A front bezel is included. The #7182 is functionally equivalent to a #7884 520 Rack Mount, but the bezel has the System i5 name. Add #7198 Adjustable Depth Rack Rails to the #7182 if adjustable length rails are needed.</p> <p>Supported on rack mounted 520+ models.</p> <p>The #7182 is a Customer Install Feature.</p>
#7183	<p>#7183 550 Rack Mount</p> <p>The #7183 indicates this is a rack-mounted system unit. The system ships with IBM mounting rails for installation in an IBM standard 19-inch rack. Rails are adjustable up to a 29.25 inch depth. A front bezel is included. The #7183 is functionally equivalent to a #7886 550 Rack Mount, but the bezel has the System i5 name.</p> <p>Supported on rack mounted 550+ models.</p> <p>The #7183 is a Customer Install Feature.</p>
#7194	<p>#7194 Easy-Access Front Cover</p> <p>The #7194 provides a front cover for the deskside Model 550 which has an easy access bezel. The #7194 is functionally equivalent to a #7751 Easy-Access Front Cover, but has the System i5 name.</p> <p>Supported on deskside 550+ models.</p> <p>The #7194 is a Customer Install Feature.</p>
#7197	<p>#7197 570 Front Bezel</p> <p>The #7197 provides a front bezel for the Model 570. The #7197 is functionally equivalent to the bezel previously provided without a feature code on the Model 570, but has the System i5 name.</p> <p>Supported on Model 570+.</p> <p>The #7197 is a Customer Install Feature.</p>
#7198	<p>#7198 Adjustable Depth Rack Rails</p> <p>The #7198 provides rails that are adjustable to a depth of 29.5 inches for mounting a Model 520 system unit in a non-IBM rack. The fixed depth rail provided in the required #7884 520 Rack Mount specify code are replaced by the adjustable rails. The adjustable rails are installed by the client. The combination of #7884 and #7198 is equivalent to a #7883 specify feature.</p> <p>Supported on Model 520+.</p> <p>The #7198 is a Customer Install Feature.</p>

#7199	<p>#7199 Acoustic Front Door The #7199 provides a front door which has acoustic dampening capabilities for the deskside Model 550 system. The #7199 is functionally equivalent to a #7754 Acoustic Front Door, but has the System i5 name and accent color.</p> <p>Supported on desk Model 550+. The #7199 is a Customer Install Feature.</p>
#7307	<p>#7307 Dual I/O Unit Enclosure The #7307 Dual I/O Unit Enclosure provides the mounting hardware, with adjustable rails, required to install a #5790 I/O drawer in a #0551, #0553, #0554, or #0555 rack. The enclosure can accommodate two #5790 drawers, side by side, but it can also be used with only one #5790 drawer installed.</p> <p>The #7307 and #7311 are functionally equivalent except the #7307 can be used in the #0554 and #0555 racks and has rails adjustable to 29.25 inches depth. Four EIA units of rack space are required in a #0551, #0553, #0554 or #0555 rack.</p> <p>Supported on Models 520+, 550+, 570+, 595 1.9 GHz, 520, 550, 570, 595, and 9411-100. The #7307 is a Customer Install Feature.</p>
#7311	<p>#7311 Dual I/O Unit Enclosure The #7311 Dual I/O Unit Enclosure provides the mounting hardware required to install a #5790 PCI Expansion Drawer in a #0551, #0553, #0554, #0555 iSeries Rack. The enclosure can accommodate two #5790 drawers, side by side, but it can also be used with only one #5790 unit installed. Four EIA units of rack space are required in a #0551 or #0553 rack.</p> <p>Supported on Models 520+, 550+, 570+, 595 1.9 GHz, 520, 550, 570, 595, and 9411-100. The #7311 is a Customer Install Feature.</p>
#7750	<p>#7750 - Easy access Front Cover The #7750 provides an easy access front cover for the deskside Model 520.</p> <p>Supported on deskside Model 520. The #7750 is a Customer Install Feature.</p>
#7751	<p>#7751 - Easy Access Front Cover The #7751 provides an easy access front cover for the deskside Model 550.</p> <p>Supported on deskside Model 550. The #7751 is a Customer Install Feature.</p>
#7753	<p>#7753 - Acoustic Front Door The #7753 provides an acoustic front door fro the deskside Model 520.</p> <p>Supported on deskside Model 520. The #7753 is a Customer Install Feature.</p>
#7754	<p>#7754 - Acoustic Front Door The #7754 provides an acoustic front door fro the deskside Model 550.</p> <p>Supported on deskside Model 550. The #7754 is a Customer Install Feature.</p>
#7768	<p>#7768 CPU Power Regulator The #7768 provides a redundant processor power regulator for the Model 570 single enclosure system. One #7768 can be ordered to provide hot-plug redundant power regulation.</p> <p>Minimum operating system level: i5/OS V5R3 Supported single enclosure Model 570+ system only. The #7768 is a Customer Install Feature.</p>

#7780	<p>#7780 2.0m Rack Side Attach Kit</p> <p>The #7780 allows a row of racks without side panels to be bolted together in a continuous suite, using the provided side-to-side rack connecting hardware. When multiple racks are joined in this way, cables can be easily run between racks without exiting the continuous rack enclosure. A small gap is maintained between the two adjacent racks, which is filled by three matching steel trim pieces that snap into place on the front, top, and rear, between each rack. Side panels are needed only for the two end racks of the suite.</p> <p>Supported on #0553 iSeries 2.0 m Rack. Initial order or MES. The #7780 is a Customer Install Feature.</p>
#7798	<p>#7798 Model 550 Non-IBM Rack Mount</p> <p>The #7798 provides the necessary hardware to mount a Model 550 system unit in an non-IBM rack. The #7798 fits deeper racks than the standard IBM 28-inch rack depth. Model 550 system orders containing #7798 are integrated into a non-IBM rack at the customer location. The #7798 is a Customer Install Feature.</p>
#7818	<p>#7818 HSL-2/RIO-G 2-Ports Copper</p> <p>The #7818 is a 2 port (copper) HSL-2/RIO-G bus adapter which provides connections for one HSL-2/RIO-G loop. The #7818 is installed into an empty slot on one processor book. Initial order or MES</p> <p>Minimum operating system level: i5/OS V5R3, AIX 5L for POWER V5.2, AIX 5L for POWER V5.2 The #7818 is an IBM Customer Service Representative setup feature.</p>
#7819	<p>#7819 HSL/RIO 2-Ports Optical</p> <p>The #7819 is a 2 port optical HSL/RIO bus adapter which provides connections for one optical HSL/RIO loop. It is installed into an empty slot on one processor book. Initial order or MES Minimum operating system level: i5/OS V5R3, SUSE Linux Enterprise Server 9 for POWER or Red Hat Enterprise Linux AS for POWER Version 3, AIX 5L for POWER V5.2 The #7819 is an IBM Customer Service Representative setup feature. The #7819 is withdrawn from marketing as of 30 August 2005.</p>
#7837	<p>#7837 Bulk Power Distribution</p> <p>The #7837 is a power distribution assembly which provides connector locations for cable attachment of I/O drawers and system unit DC power converters on a Model 595. It provides 10 power connectors. Initial order or MES. The #7837 is an IBM Customer Service Representative setup feature.</p>
#7840	<p>#7840 Side-by-Side for 1.8m Racks</p> <p>The #7840 allows a row of racks without side panels to be bolted together in a continuous suite, using the provided side-to-side rack connecting hardware. When multiple racks are joined in this way, cables can be easily run between racks without having to exit the continuous rack enclosure. A small gap is maintained between the two adjacent racks, which is filled by three matching steel trim pieces that snap into place on the front, top, and rear, between each rack. The trim pieces cover the space between each rack for an enhanced appearance and for additional protection of the equipment inside the racks. Side panels are needed only for the two end racks of the suite. The #7840 is a Customer Install Feature.</p>
#7841	<p>#7841 Rugged Rack Kit</p> <p>The #7841 Rugged Rack Kit provides additional hardware that reinforces the rack and anchors it to the floor. The #7841 kit is designed to provide enhanced rigidity and stability for racks primarily installed in locations where earthquakes are a concern. The feature includes a large steel brace or truss that bolts into the rear of the rack. It is hinged on the left side so it can swing out of the way for easy access to the rack drawers when necessary. The #7841 also includes hardware for bolting the rack to a concrete floor or a similar surface, and bolt-in steel filler panels for any unoccupied spaces in the rack.</p> <p>Supported on Model 9411-100. The #7841 is a Customer Install Feature.</p>
#7861	<p>#7861 Blind Swap Cassette (Short)</p> <p>The #7861 provides a short, type 3, blind swap cassette for use in the Model 570 system unit.</p> <p>Supported on Models 570 and 9411-100. The #7861 is a Customer Install Feature.</p>

#7862	<p>#7862 Blind Swap Cassette (Long) The #7862 provides a standard length, type 3, blind swap cassette for use in the Model 570 system unit.</p> <p>Supported on Models 520, 550, 570, 595, and 9411-100. The #7862 is a Customer Install Feature.</p>
#7863	<p>#7863 Blind Swap Cassette (Double) The #7863 provides a double wide standard length, type 3, blind swap cassette for the Integrated xseries Server used in the Model 570 system unit.</p> <p>Supported on Models 520, 550, 570, 595, and 9411-100. The #7863 is a Customer Install Feature.</p>
#7875	<p>#7875 CPU Power Regulator The #7875 is a processor power regulator for the Model 570. One #7875 is required per processor card. A single redundant #7875 can be ordered to provide redundant power regulation for the Model 570.</p> <p>Supported on Model 570. The #7875 is a Customer Install Feature.</p>
#7881	<p>#7881 Service Processor The #7881 is the Model 570 Service Processor. The #7881 contains the system Rack Indicator Port, two SPCN (RS485) ports for control of attached I/O subsystems, and two Service Processor Ethernet /HMC ports.</p> <p>Supported on Model 570. The #7881 is a Customer Install Feature. The #7881 is withdrawn from marketing as of 01 April 2005.</p>
#7882	<p>#7882 SCSI to IDE Converter Card The #7882 is a SCSI to integrated development environment (IDE) converter card used on the Model 570 to convert the removable media bays from IDE format to SCSI. Although #7882 converts one IDE media bay to SCSI, it geographically requires both slots.</p> <p>Supported on Model 570. The #7882 is a Customer Install Feature.</p>
#7883	<p>#7883 Model 520 Non-IBM Rack Mount The #7883 provides the necessary hardware to mount a Model 520 system unit in an non-IBM rack. The #7883 fits deeper racks than the standard IBM 28-inch rack depth. Model 520 system orders containing #7883 are integrated into a non-IBM rack at the customer location.</p> <p>The #7883 is a Customer Install Feature.</p>
#7884	<p>#7884 520 Rack Mount The #7884 indicates that this order is for a rack-mount Model 520 system. The system ships with fixed length IBM mounting rails for installation in an IBM rack.</p> <p>Conversion from #7884 520 Rack Mount to #7885 520 Deskside is available first quarter 2005. The #7884 is a Customer Install Feature.</p>
#7885	<p>#7885 520 Deskside The #7885 indicates that this order is for a deskside Model 520 system.</p> <p>Conversion from #7885 520 Deskside to #7884 520 Rack Mount is available first quarter 2005. The #7885 is a Customer Install Feature.</p>
#7886	<p>#7886 550 Rack Mount The #7886 indicates that this order is for a rack-mount Model 550 system. The system ships with fixed length IBM mounting rails for installation in an IBM rack.</p> <p>The #7886 is a Customer Install Feature.</p>
#7887	<p>#7887 550 Deskside The #7887 indicates that this order is for a deskside Model 550 system.</p> <p>The #7887 is a Customer Install Feature.</p>
#7889	<p>Redundant Power Supply The #7889 is an optional 1475W power supply, which provides redundant power for the Model 550 system unit. A second line cord is required.</p> <p>Supported on Model 550. The #7889 is a Customer Install Feature.</p>

#7937	<p>#7937 - 595 Bolt-Down (Lo Raised FI)</p> <p>The #7937 provides Rack ruggedizing and bolt-down hardware for securing a 24-inch rack to a concrete floor beneath a 9.25" to a 11.75" (235 mm to 298 mm) raised floor. Installation of this feature helps to secure and protect the rack and its contents from damage when exposed to vibrations and shocks, such as those in a seismic event</p> <p>Supported on Model 595.</p> <p>The #7937 is not a Customer Install Feature.</p>
#7938	<p>#7938 - 595 Bolt-Down (Hi Raised FI)</p> <p>The #7938 provides Rack ruggedizing and bolt-down hardware for securing a 24-inch rack to a concrete floor beneath a 11.75" to 16.0" (298 mm to 405 mm) raised floor. Installation of this feature helps to secure and protect the rack and its contents from damage when exposed to vibrations and shocks, such as those in a seismic event.</p> <p>Supported on Model 595.</p> <p>The #7938 is not a Customer Install Feature.</p>
#7939	<p>#7939 - 595 Bolt-Down (Non-Raised FI)</p> <p>The #7939 provides Rack ruggedizing and bolt-down hardware for securing a 24-inch rack to a concrete floor. Installation of this feature helps to secure and protect the rack and its contents from damage when exposed to vibrations and shocks, such as those in a seismic event.</p> <p>Supported on Model 595.</p> <p>The #7939 is not a Customer Install Feature.</p>
#7940 #7941 #7942 #7992	<p>#7940, #7941, #7942, #7992 - Advanced Power Virtualization</p> <p>The #7940, #7941, #7942, and #7992 provide both Virtual I/O Server and Partition Load Manager capability. The Virtual I/O Server is a special-purpose partition that provides virtual I/O resources to AIX 5L and Linux client partitions. The Virtual I/O Server owns the resources that are shared with clients. A physical adapter assigned to a partition can be shared by one or more other partitions, enabling administrators to minimize the number of physical adapters they require for individual clients. The Virtual I/O Server helps reduce costs by eliminating the need for dedicated network adapters, disk adapters, and disk drives.</p> <p>The Partition Load Manager (PLM) provides automated processor and memory distribution between dynamic LPARs and Micro-Partition-capable LPARs running the AIX 5L operating system. The PLM application is based on a client/server model for the sharing of system information, such as processor or memory events, across concurrent present LPARs.</p> <p>Each feature ordered provides one processor authorization. One processor authorization is required for each processor's worth of workload used across all partitions utilizing Advanced POWER Virtualization.</p> <p>Supported on #7940 Model 520, #7941 Model 550, #7942 Model 570, #7992 Model 595.</p> <p>The #7940, #7941, #7942, #7992 are Customer Install Features.</p>
#7997	<p>#7997 - Service Processor</p> <p>The #7997 provides optional redundant service processor function for the Model 570. One service processor is included in each Model 570. Initial iSeries Model 570 shipments did not use a feature code to designate the presence of the first service processor. Later Model 570 shipments use feature #8420 to designate the first service processor.</p> <p>The #7997 contains the system Rack Indicator Port, two SPCN (RS485) ports for control of attached I/O subsystems, and two Service Processor Ethernet / Hardware Management Console (HMC) ports.</p> <p>Because a second Model 570 processor enclosure is required for the #7997, it cannot be installed in 1/2-way and 2/4-way servers.</p> <p>Supported on Model 570.</p> <p>The #7997 is a Customer Install Feature.</p>

#8093	<p>#8093 Optional 1.8 M I/O Rack</p> <p>The #8093 Optional 1.8 M I/O Rack is an optional base I/O rack shipped on the Model 890 instead of a #9094 Base PCI I/O Enclosure. The #8093 supports up to 90 disk units with a #5101/#5111 installed in the top unit and a #5107/#5117 installed in the lower unit, up to 28 PCI IOA slots, and up to four removable media units. A #9691/#9739 HSL bus adapter is required for the upper unit. The #8093 has two battery back up units and redundant or hot swap power supplies.</p> <p>The PCI IOAs are supported (driven) by two #9943 Base PCI IOPs and #2843/#2844/#2847 PCI IOPs, or the #2792/#2799 PCI Integrated xSeries Server. An #8093 is a #9094 Base PCI I/O Enclosure with a #5074 (#0574 specify code) tower packaged in a rack.</p> <p>The #8093 is capable of controlling Ultra2 SCSI disk units. It also supports up to three additional removable media devices (internal tape or CD-ROM or DVD-ROM/RAM). The following removable media devices are supported by a #2757, #2780, #4748, or #4778 PCI RAID Disk Unit Controller. If the top enclosure is to be attached to a different system than ordered, process an RPO to remove the #0574 specify code from the initially ordered machine and add it to the target machine.</p> <p>The #8093 can be converted to a #5097.</p> <p>Select three or four of the following HSL cables depending on the requirements of optical and copper HSL:</p> <ul style="list-style-type: none">▶ #1482 - 3.5m HSL-2 Cable▶ #1483 - 10m Optical HSL-2 Cable▶ #1485 - 15m HSL-2 Cable <p>And select two (any combination) of the following HSL to HSL-2 cables:</p> <ul style="list-style-type: none">▶ #1474 - 6m HSL to HSL-2 Cable▶ #1475 - 10m HSL to HSL-2 Cable <p>Select two of the following SPCN cables per tower:</p> <ul style="list-style-type: none">▶ #0369 100m Optical SPCN Cable▶ #1463 - 2m SPCN Cable▶ #1464 - 6m SPCN Cable▶ #1465 - 15m SPCN Cable▶ #1466 - 30m SPCN Cable▶ #1468 - 250m Optical SPCN Cable <p>Specify two line cords for the #8093 Optional 1.8 M I/O Rack. Some countries or regions offer fewer choices of line cords and some countries or regions are shipped a default line cord type. Supported for conversion only on the Model 570 and 595; cannot be ordered. The #8093 is a Customer Install Feature.</p>
-------	--

#8094	<p>#8094 Optional 1.8 M I/O Rack</p> <p>The #8094 Optional 1.8 M I/O Rack is a racking option for the Model 890. It supports up to 90 disk units, has 28 PCI-X IOP/IOA slots, and has four removable media bays. The #8094 consists of a 1.8 m rack with two enclosures. The bottom enclosure is essentially a #9094 Base PCI I/O Enclosure with side covers and casters removed and with the #5107 30 Disk Expansion included as base (no feature code required). The bottom unit includes a #9587. The top enclosure is essentially a #5094 PCI-X Expansion Tower with side covers and casters removed, and with the #5108 30-Disk Expansion Feature included as base (no feature code required). The top unit includes a #9886 or #9887, #9876 or #9877 or #9715.</p> <p>Included with the bottom enclosure are one JTAG cable and one V/S Communications (VPD and SPCN) cable to attach the bottom enclosure to the Model 890 system unit. Also included are a #9887 Base HSL-2 Bus Adapter and #9844 Base PCI IOP. A #2757 PCI-X Ultra™ RAID Disk Controller or #4748/#4778 PCI RAID Disk Unit Controller is required with this unit.</p> <p>Included with the top enclosure is a #9887 Base HSL-2 Bus Adapter or a #9886 Base Optical Bus Adapter to provide the HSL interface to the system (specify one, one feature code required), #0694 - #5094 Equivalent (feature code required), and #9844 Base PCI IOP (feature code required).</p> <p>Each enclosure supports 45 disk unit positions for a total of 90 disk units. The 45 disk unit positions are in groups of 15. Each group of 15 disk units is further divided into three groups of five disk units. Each group of five disk units is supported on a separate Ultra4 SCSI (LVD-SCSI) bus from a #2757, #2780, #4748, or #4778 PCI RAID Disk Unit Controller. See the PCI Expansion Tower layout and disk unit plugging sequence diagrams in 6.1, "System i towers, racks, and expansion unit schematics" on page 277. Each group of 15 disk units requires support by one #2757, #2780, #4748, or #4778 PCI RAID Disk Unit Controller.</p> <p>The #5294 and #8094 expansion towers offer additional LPAR configuration flexibility. Instead of the previous maximum number of six disk controllers supported in a #5294/#8094, now up to eighteen total disk controllers are supported. These can be either OS/400 controlled (maximum of six OS/400 partitions) or Linux controlled. The #5703/#0628 disk controller can be used to go beyond the maximum of three, already supported #2757, #2780, #4748, and #4778 disk controllers per top or bottom unit of the #5294/#8094.</p> <p>Each tower must have at least one #2748, #2757, #2780, #4748, or #4778 for each group of 15 disk units in the tower. Only the #5703/#0628 can be ordered as an extra controller (up to two #5703/#0628s per group of 15 disk units in the same tower) #0143 Disk Controller Placement Exception is also ordered. The #2748, #2757, #2780, #4748, or #4778 disk controllers cannot be ordered as extra controllers if #0143 is also ordered.</p> <p>The #8094 Optional 1.8 M I/O Rack supports up to four removable media devices (internal tape, CD-ROM, and DVD). The following removable media devices are supported by the two #2757, #2780, #4748, or #4778 PCI RAID Disk Unit Controllers which support the first group of 15 disk units in each enclosure.</p> <p>The two enclosures in the #8094 Optional 1.8 M I/O Rack are separately attached to the system unit via HSL cables as though they were a stand-alone #9094 Base PCI I/O Enclosure and #5094 PCI-X Expansion Tower. They are treated as separate units for HSL loop plugging and configuration rules and recommendations. The bottom enclosure must be attached to the system unit's first HSL loop. Both enclosures can be connected to the first HSL loop. The top enclosure of the #8094 can be used on a different system than the bottom enclosure, but cannot be ordered this way. To use the top enclosure on another system, after the system is received, process an RPO to remove the #0694 or #5094 Equivalent from the records of the original ordered system and add it to the records of the other system.</p> <p>For the Model 800 and 810, if the #8094 attaches to HSL ports A0 or A1, the HSL cable cannot exceed 6 m. For the Model 820, if the #8094 attaches to the HSL port A1 of the system unit, the HSL cable connection to port A1 cannot exceed 6 m.</p> <p>Select an appropriate number of the following HSL/HSL-2 cables:</p> <ul style="list-style-type: none"> ▶ #1307 - 1.75m Copper HSL-2 Cable ▶ #1470 - 6m Optical HSL Cable ▶ #1471 - 30m Optical HSL Cable ▶ #1473 - 250m Optical HSL Cable ▶ #1474 - 6m HSL to HSL-2 Cable ▶ #1475 - 10m HSL to HSL-2 Cable ▶ #1482 - 3.5m HSL-2 Cable ▶ #1483 - 10m HSL-2 Cable ▶ #1485 - 15m HSL-2 Cable
-------	--

#8094
(cont.)

#8094 Optional 1.8 M I/O Rack

Select two line cords from the following list for the lower enclosure (#9094 Base PCI I/O Enclosure):

- ▶ #1451 - 200V 6-ft Line Cord
- ▶ #1452 - 200V 14-ft Line Cord
- ▶ #1453 - 200V 6-ft Locking Line Cord
- ▶ #1454 - 200V 12A 14-ft TL Line Cord (Default-US)
- ▶ #1455 - 200V 6-ft Watertight Line Cord
- ▶ #1456 - 200V 14-ft Watertight Line Cord
- ▶ #1406 - 200V 16A 14-ft TL Line Cord
- ▶ #1408 - 4.3m 200V/16A Power Cord Italy
- ▶ #1409 - 4.3m 200V/16A Power Cord AU/NZ
- ▶ #1418 - 4.3m 200V/16A Power Cord S Africa
- ▶ #1419 - 4.3m 200V/16A Power Cord Israel
- ▶ #1420 - 4.3m 200V/16A Power Cord CH/DK
- ▶ #1421 - 4.3m 200V/16A Power Cord EU/Asia
- ▶ #1476 - 4.3m 200V 12A Power Cord UK

If a #5115 Dual Line Cords Tower is not present, select one line cord from the following list for the upper enclosure (#5094).

If a #5115 Dual Line Cords Tower is present, select two line cords from the following list for the upper enclosure (#5094):

- ▶ #1406 - 200V 16A 14-ft TL Line Cord
- ▶ #1408 - 4.3m 200V/16A Power Cord Italy
- ▶ #1409 - 4.3m 200V/16A Power Cord AU/NZ
- ▶ #1418 - 4.3m 200V/16A Power Cord S Africa
- ▶ #1419 - 4.3m 200V/16A Power Cord Israel
- ▶ #1420 - 4.3m 200V/16A Power Cord CH/DK
- ▶ #1421 - 4.3m 200V/16A Power Cord EU/Asia
- ▶ #1451 - 200V 6-ft Line Cord
- ▶ #1452 - 200V 14-ft Line Cord
- ▶ #1453 - 200V 6-ft Locking Line Cord
- ▶ #1454 - 200V 12A 14-ft TL Line Cord (default-U.S.)
- ▶ #1455 - 200V 6-ft Watertight Line Cord
- ▶ #1456 - 200V 14-ft Watertight Line Cord
- ▶ #1457 - 200V 6-ft Upper Line Cord
- ▶ #1458 - 200V 6-ft Upper Locking Cord
- ▶ #1459 - 200V 6-ft Upper Watertight Cord
- ▶ #1476 - 4.3m 200V 12A Power Cord UK

Select one of the following SPCN cables (for the upper unit):

- ▶ #0369 100m Optical SPCN Cable
- ▶ #1463 - 2m SPCN Cable
- ▶ #1464 - 6m SPCN Cable
- ▶ #1465 - 15m SPCN Cable
- ▶ #1466 - 30m SPCN Cable
- ▶ #1468 - 250m Optical SPCN Cable
- ▶ #6001 Power Control Cable - 2M
- ▶ #6006 Power Control Cable - 3M
- ▶ #6007 Power Control Cable - 15M
- ▶ #6008 Power Control Cable - 6M
- ▶ #6029 Power Control Cable - 30M

The #8094 Optional 1.8 M I/O Rack reports to the system as CCIN 8094-001 for the bottom enclosure and 8094-002 for the top enclosure.

Minimum operating system level: OS/400 V5R2

The #8094 is not a Customer Install Feature.

The #8094 is withdrawn from marketing as of 01 October 2005.

#8294	<p>#8294 Optional Base 1.8m Rack</p> <p>The #8294 is a racking option for a Model 595. It supports up to 90 disk units, has 28 PCI-X slots and has four removable media slots. The #8294 consists of a 1.8m rack with two enclosures; a bottom enclosure and a top enclosure.</p> <p>The bottom enclosure is essentially a #9194 Base PCI-X Expansion Tower with side covers and casters removed and with a 30-disk expansion feature included as base (no feature code required).</p> <p>The top enclosure is essentially a #5094 PCI-X Expansion Tower with side covers and casters removed and a 30-disk expansion feature included as base (no feature code required). Included with the bottom enclosure is a #9517 Base HSL-2/RIO-G Bus Adapter and a #9844 Base PCI IOP. Also, a #2780 PCI-X Ultra4 RAID Disk Controller is required to drive the load source DASD and the removable media devices. Included with the top enclosure is a #9517 Base HSL-2/RIO-G Bus Adapter or a #9876 Base Optical Bus Adapter (select one), a #9844 Base PCI IOP and a #0694 - #5094 Equivalent.</p> <p>Each enclosure supports 45 disk units for a total of 90 disk units. The 45 disk unit positions are partitioned into groups of 15, and each group of 15 requires support by one #2780 PCI-X Ultra4 RAID Disk Controller. Each group of 15 is further divided into groups of 5 disk units, each group of 5 disk units supported on a separate Ultra4 SCSI bus from the #2780 PCI-X Ultra4 RAID Disk Controller.</p> <p>The tower and drawer configurations longer include a #9844 Base PCI IOP as of 31 January 2006 with the announcement of IOP-less support in IBM System i5 and eServer i5 servers. Refer to “#9844 Inclusion Rules” on page 174.</p> <p>The #8294 also supports up to four removable media devices. These removable media devices are supported by the two #2780 PCI-X Ultra4 RAID Disk Controllers which support the first group of 15 disk units in each enclosure.</p> <p>The two enclosures in the #8294 are separately attached to the system unit via HSL cables as though they are stand-alone #9194 and #5094. The bottom enclosure must be on the first HSL loop attached via two HSL-2/RIO-G cables to the system unit and the top enclosure can be on this same HSL loop or a separate HSL loop. The top enclosure can be attached via HSL to a different system than the bottom enclosure, but cannot be ordered this way. When the system is received, process an RPO to remove the #0694 from the records of the original ordered system and add it to the records of the other system.</p> <p>An HSL loop uses all optical or all copper ports/cables. A copper loop can intermix I/O towers/units with copper HSL and copper HSL-2 ports. Select the appropriate cable based on the type of HSL ports to which it is being attached, and the cable length required.</p> <p>The following HSL cables can be used with an #8294:</p> <ul style="list-style-type: none"> ▶ #1307 -1.75m Copper HSL-2 Cable ▶ #1308 -2.5m Copper HSL-2 Cable ▶ #1460 - 3m Copper HSL Cable ▶ #1461 - 6m Copper HSL Cable ▶ #1462 - 15m Copper HSL Cable ▶ #1470 - 6m Optical HSL Cable ▶ #1471 - 30m Optical HSL Cable ▶ #1472 - 100m Optical HSL Cable ▶ #1473 - 250m Optical HSL Cable ▶ #1474 - 6m HSL to HSL-2 Cable ▶ #1475 - 10m HSL to HSL-2 Cable ▶ #1481 - 1m HSL-2 Cable ▶ #1482 - 3.5m HSL-2 Cable ▶ #1483 - 10m HSL-2 Cable <p>Both the top and bottom enclosures in the #8294 must be connected via SPCN cables, they must be in an SPCN cable loop. Three SPCN cables are required to connect both enclosures of the #8294 to the ports of the system unit. If the top enclosure of the #8294 is attached to a different system unit, then the top enclosure is connected to the SPCN cable loop of that system and one or two SPCN cables are required.</p> <p>The #8294 is a Customer Install Feature.</p>
-------	---

<p>#8294 (cont.)</p>	<p>#8294 Optional Base 1.8m Rack</p> <p>Select three or four of the following SPCN cables for each #8294:</p> <ul style="list-style-type: none"> ▶ #1463 - 2m SPCN Cable ▶ #1464 - 6m SPCN Cable ▶ #1465 - 15m SPCN Cable ▶ #1466 - 30m SPCN Cable ▶ #0369 100m Optical SPCN Cable ▶ #1468 - 250m Optical SPCN Cable ▶ #6001 Power Control Cable - 2M ▶ #6006 Power Control Cable - 3M ▶ #6007 Power Control Cable - 15M ▶ #6008 Power Control Cable - 6M ▶ #6029 Power Control Cable - 30M <p>Dual line cord capability is required with the bottom enclosure of the #8294, #5164 Dual Power Cord is required on the order. Dual line cord capability is also required on the top enclosure of the #8294, with a #5165 Dual Power Cord, if the top enclosure is attached to the same system unit as the bottom enclosure. If the top enclosure is attached to a different system unit, then #5165 is optional. An additional line cord (for a total of four) must be ordered when a #5165 is installed. Plugging in the second line cord, even if to the same outlet, enables the AC power modules to be redundant.</p> <p>The following line cords are supported on an #8294 (three or four line cord features required):</p> <ul style="list-style-type: none"> ▶ #1399 - 4.3m 300V/16A ▶ #1406 - 200V 16A 14-ft TL Line Cord ▶ #1408 - 4.3m 200V/16A Power Cd Italy ▶ #1409 - 4.3m 200V/16A Per Cd AU/NZ ▶ #1418 - 4.3m 200V/16A Per Cd S Africa ▶ #1419 - 4.3m 200V/16A Per Cd Israel ▶ #1420 - 4.3m 200V/16A Per Cd EU/Asia ▶ #1421 - 4.3m 200V/16A Per Cd CH/DK ▶ #1451 - 200V 6-ft Line Cord ▶ #1452 - 200V 14-ft Line Cord ▶ #1453 - 200V 6-ft Locking Line Cord ▶ #1454 - 200V 12A 14-ft TL Line Cord ▶ #1455 - 200V 6-ft Watertight Line Cord ▶ #1456 - 200V 14-ft Watertight Line Cord ▶ #1476 - 4.3m 200V/12A Power Cd UK <p>Initial order or MES Minimum operating system level: i5/OS V5R3, SUSE Linux Enterprise Server 9 for POWER or Red Hat Enterprise Linux AS for POWER Version 3, AIX 5L for POWER V5.2 The #8294 is a Customer Install Feature.</p>
<p>#8420</p>	<p>#8420 - Base Service Processor</p> <p>Provides service processor function for the Model 570. #8420 contains the system Rack Indicator Port, two SPCN (RS485) ports for control of attached I/O subsystems, and two Service Processor Ethernet/Hardware Management Console (HMC) ports.</p> <p>Supported on Model 570. The #8420 is a Customer Install Feature.</p>
<p>#8453</p>	<p>#8453 - Base custom placement</p> <p>The #8453 places hardware components as directed by hardware placement information from the LPAR Verification Tool (LVT). The #8453 is supported on new system builds only.</p> <p>If #8453 is not on the initial order, hardware placement can be provided at the customer site by IBM Global Services for a fee.</p> <p>Initial order or MES Supported on Model 570. Customer Install Feature: n/a</p>

<p>#9074</p>	<p>#9074 Base I/O Tower</p> <p>The #9074 Base I/O Tower is the base I/O tower shipped on the Model 830. The #9074 supports up to 45 disk units (15 units are "base", with an additional 30 provided with #5101 or #5111), up to 11 PCI IOAs, up to two removable media units, one battery backup, and redundant or hot swap power supplies. The #9074 has a #9943 Base PCI IOP and a #9748 Base PCI RAID Disk Unit Controller. The 14 PCI slots are used and supported (driven) by the #9943 Base PCI IOP and by #2843/#2844/#2847 PCI IOPs.</p> <p>The #2790 PCI Integrated Netfinity Server or the #2791/#2792/#2799 PCI Integrated xSeries Server can also support selected LAN cards.</p> <p>The #1460 - 3m Copper HSL Cable is included automatically on the order.</p> <p>Select an additional two of the following HSL cables when the Model 830 is in a clustered loop with the Models 825, 870, or 890:</p> <ul style="list-style-type: none"> ▶ #1474 - 6m HSL to HSL-2 Cable ▶ #1475 - 10m HSL to HSL-2 Cable <p>One #14xx power cord must be specified (geography dependent). See 11.2, "SPCN (power) cables" on page 382 for power cord options.</p> <p>The #9074 is capable of controlling Ultra2 SCSI disk units. The two removable media devices (internal tape, CD-ROM or DVD) are supported by the #9748/#9778. The #9074 is a Customer Install Feature. The #9074 is withdrawn from marketing as of 01 January 2004. A #5074 attached to the Model 520 or 570 is the recommended replacement.</p>
<p>#9079</p>	<p>#9079 Base I/O Tower</p> <p>The #9079 Base I/O Tower is the base I/O tower shipped on the Model 840. The #9079 supports up to 45 disk units (15 are "base", with an additional 30 provided with #5101 or #5111), up to 11 PCI IOAs, up to two removable media units, one battery backup, and redundant or hot swap power supplies. The #9079 has a #9943 Base PCI IOP and a #9748 Base PCI RAID Disk Unit Controller. The 14 PCI slots are used and supported (driven) by the #9943 Base PCI IOP and by #2843/#2844/#2847 PCI IOPs. The #2790 PCI Integrated Netfinity Server or the #2791/#2792/#2799 PCI Integrated xSeries Server can also support selected LAN cards.</p> <p>Select two (any combination) of the following HSL cables:</p> <ul style="list-style-type: none"> ▶ #1460 - 3m Copper HSL Cable ▶ #1461 - 6m Copper HSL Cable ▶ #1462 - 15m Copper HSL Cable <p>Select an additional two of the following HSL cables, when the Model 840 is in a clustered loop with Model 825, 870 or 890:</p> <ul style="list-style-type: none"> ▶ #1474 - 6m HSL to HSL-2 Cable ▶ #1475 - 10m HSL to HSL-2 Cable <p>Select one of the following SPCN cables per tower:</p> <ul style="list-style-type: none"> ▶ #1463 - 2m SPCN Cable ▶ #1464 - 6m SPCN Cable ▶ #1465 - 15m SPCN Cable ▶ #1466 - 30m SPCN Cable <p>One #14xx power cord (two when dual line cord feature #5104 is ordered for the 840 system unit) feature must be specified (geography dependent). See Chapter 11, "HSL, SPCN, line cord, and communication cables for IBM System i5, eServer i5, and iSeries systems" on page 377 for power and line cord options.</p> <p>The #9079 is capable of controlling Ultra2 SCSI disk units. The two removable media devices (internal tape, CD-ROM, and DVD) are supported by the #9748/#9778 PCI Raid Disk Unit Controller.</p> <p>Supported on Models 840, 870, 890. The #9079 is a Customer Install Feature.</p>

#9094	<p>#9094 Base PCI I/O Enclosure</p> <p>The #9094 Base PCI I/O Enclosure is the base enclosure shipped with the 870 and 890 system units to constitute a system. The #9094 is attached to the system unit via HSL cable through a #9887 Base HSL-2 Bus Adapter. A #9887 Base HSL-2 Bus Adapter is required on the order. One JTAG cable and one V/S Communications cable (VPD and SPCN combined) are included for the attachment of the #9094 to the system unit.</p> <p>The #9094 Base PCI I/O Enclosure has 15 disk unit slots, with an additional 30 slots available with #5107 30 Disk Expansion. The #9094 also has two removable media slots and 14 PCI-X card slots. A #9844 Base PCI IOP or #9943 Base PCI IOP is included (feature code required) and a #2757 PCI-X Ultra RAID Disk Controller or #4748/#4778 PCI RAID Disk Unit Controller is required. The #2757, #2780, #4748, or #4778 drives the disk units in the base 15 disk unit slots and the removable media devices in the two removable media slots. The #2757, #2780, #4748, or #4778 disk unit controllers (one or two) are required to drive the disk units in the 30 feature disk unit slots. The disk unit slots (both base and feature) are in groups of 15. Each group of 15 is further divided into three groups of five disk units. Each group of five disk units is on a separate SCSI bus from a #4748/#4778/#2757/#2780/#5703/#5715</p> <p>The #5094 and #9094 expansion towers offer additional LPAR configuration flexibility. Instead of the previous maximum number of three disk controllers supported in a #5094/#9094, now up to nine total disk controllers are supported. These can be either OS/400 controlled (maximum of six OS/400 partitions) or Linux controlled. The #5294 and #8094 are similarly enhanced and now support a maximum of 18 disk controllers. The #5703/#0628 disk controller can be used to go beyond the maximum of three, already supported #2757, #2780, #4748, and #4778 disk controllers.</p> <p>Each tower must have at least one #2748, #2757, #2780, #4748, or #4778 for each group of 15 disk units in the tower. Only the #5703/#0628 can be ordered as an extra controller (up to two #5703/#0628s per group of 15 disk units in the same tower) if #0143 Disk Controller Placement Exception is also ordered. The #2748, #2757, #2780, #4748, or #4778 disk controllers cannot be ordered as extra controllers if #0143 is also ordered. A maximum of six #5703/#0628s per #5094/#9094 tower are supported</p> <p>The number of disk units per #2757 and #2780 varies by configuration: Up to 20 disk units per #2757 are supported in a #5094 PCI-X Expansion Tower attached to a Model 520, 550 570, or 595. Up to 18 disk units per #2757 are supported in the system unit with System Unit Expansion disk cages of the Model 270, 800, and 810. Up to 15 disk units per #2757 are supported in a #9094 Base PCI I/O Enclosure attached to a Model 870 or 890.</p> <p>The 14 PCI slots are used and supported (driven) by the #9844 Base PCI IOP or the #9943 Base PCI IOP, by feature #2843/#2844/#2847 PCI IOPs and by #2790/#2791/#2792/#2799 PCI Integrated xSeries Servers or #4710/#9710 Integrated xSeries Servers.</p> <p>Select two (any combination) of the following HSL cables:</p> <ul style="list-style-type: none"> ▶ #1482 - 3.5m HSL-2 Cable ▶ #1483 - 10m HSL-2 Cable ▶ #1485 - 15m HSL-2 Cable <p>With a #5114 Dual Line Cords Tower, two of the following line cords for the #9094 Base PCI I/O Enclosure are required to be specified:</p> <ul style="list-style-type: none"> ▶ #1406 - 200V 16A 14-ft TL Line Cord ▶ #1408 - 4.3m 200V/16A Power Cord Italy ▶ #1409 - 4.3m 200V/16A Power Cord AU/NZ ▶ #1418 - 4.3m 200V/16A Power Cord S Africa ▶ #1419 - 4.3m 200V/16A Power Cord Israel ▶ #1420 - 4.3m 200V/16A Power Cord EU/Asia ▶ #1421 - 4.3m 200V/16A Power Cord CH/DK ▶ #1451 - 200V 6-ft Line Cord ▶ #1452 - 200V 14-ft Line Cord ▶ #1453 - 200V 6-ft Locking Line Cord ▶ #1454 - 200V 12A 14-ft TL Line Cord (default U.S.) ▶ #1455 - 200V 6-ft Watertight Line Cord ▶ #1456 - 200V 14-ft Watertight Line Cord ▶ #1476 - 4.3m 200V/12A Power Cord UK <p>Supported on Models 870 and 890.</p> <p>The #9094 is not a Customer Install Feature. The #9094 is withdrawn from marketing as of 1 October 2005.</p>
-------	---

#9194	<p>#9194 Base PCI-X Expansion Tower</p> <p>This feature is the base PCI I/O enclosure which is shipped with a Model 595 system. The #9194 is attached to the Model 595 system unit via 2 HSL-2/RIO-G cables (HSL-2/RIO-G loop) through a #9517 Base HSL-2/RIO-G Bus Adapter. Two SPCN cables are also required to form an SPCN loop with service processor(s) in the system unit. The #9194 also has dual line cord capability; #5164 Dual Power Cords - #8294/#9194 must be on the order.</p> <p>The #9194 has 15 disk unit slots, with an additional 30 slots available with a #5168 30-Disk Expansion for the #9194 Tower. The #9194 also has 2 removable media slots and 14 PCI card slots. A #9844 Base PCI IOP is included (feature code required) and a #2780 PCI-X Ultra4 RAID Disk Controller is also required. The #2780 drives the disk units in the base 15 disk unit slots and the removable media devices in the 2 removable media slots. One or two #2780 disk unit controllers are required to drive the disk units in the 30 feature disk unit slots. The disk unit slots (both base and feature) are partitioned in groups of 15 and each group of 15 is further partitioned into three groups of five. Each group of five is on a separate Ultra4 SCSI bus from the #2780 PCI-X Ultra4 RAID Disk Controller.</p> <p>The 11 PCI IOAs are supported (driven) by the #9844 Base PCI IOP, by #2844 PCI IOP(s) and by #4810/#4812 PCI Integrated xSeries Servers.</p> <p>Select two (any combination) of the following HSL cables:</p> <ul style="list-style-type: none"> ▶ #1307 -1.75m Copper HSL-2 Cable ▶ #1308 -2.5m Copper HSL-2 Cable ▶ #1482 - 3.5m HSL-2 Cable ▶ #1483 - 10m HSL-2 Cable <p>Specify two of the following line cords for the #9194 Base PCI Enclosure:</p> <ul style="list-style-type: none"> ▶ #1451 - 200V 6-ft Line Cord ▶ #1452 - 200V 14-ft Line Cord ▶ #1453 - 200V 6-ft Locking Line Cord ▶ #1454 - 200V 12A 14-ft TL Line Cord (Default-US) ▶ #1455 - 200V 6-ft Watertight Line Cord ▶ #1456 - 200V 14-ft Watertight Line Cord ▶ #1406 - 200V 16A 14-ft TL Line Cord ▶ #1408 - 4.3m 200V/16A Power Cd Italy ▶ #1409 - 4.3m 200V/16A Power Cd AU/NZ ▶ #1418 - 4.3m 200V/16A Power Cd S Africa ▶ #1419 - 4.3m 200V/16A Power Cd Israel ▶ #1420 - 4.3m 200V/16A Power Cd EU/Asia ▶ #1421 - 4.3m 200V/16A Power Cd CH/DK ▶ #1476 - 4.3m 200V/12A Power Cd UK <p>Select two of the following SPCN cables for each #9194:</p> <ul style="list-style-type: none"> ▶ #1463 2m SPCN Cable ▶ #1464 6m SPCN Cable ▶ #1465 15m SPCN Cable ▶ #1466 30m SPCN Cable ▶ #0369 100m Optical SPCN Cable ▶ #1468 250m Optical SPCN Cable ▶ #6001 2m SPCN Cable ▶ #6006 3m SPCN Cable ▶ #6007 15m SPCN Cable ▶ #6008 6m SPCN Cable ▶ #6029 30m SPCN Cable <p>Minimum operating system level: i5/OS V5R3, SUSE Linux Enterprise Server 9 for POWER or Red Hat Enterprise Linux AS for POWER Version 3, AIX 5L for POWER V5.2 Supported on Model 595 The #9194 is a Customer Install Feature.</p>
-------	--

#9517	<p>#9517 Base HSL-2/RIO-G Bus Adapter The #9517 Base HSL-2/RIO-G Bus Adapter provides two HSL-2/RIO-G ports. The #6417 can be selected as base on initial orders of #0595, #5094, #5095, #5294 or #8294 expansion units and towers. The #9517 is a base feature version of the #6417 HSL-2/RIO-G Bus Adapter. Migration of existing #9517s to eServer i5 servers is allowed. Existing #9517s are installed in migrated #0595, #5094, #5095 and #5294 expansion towers/units.</p> <p>Minimum operating system level: i5/OS V5R3 Supported on Models 520, 550, 570, and 595. The #9517 is a Customer Install Feature.</p>
#9531	<p>#9531 Base HSL-2 Bus Adapter The #9531 Base HSL-2 Bus Adapter is a base feature on the #5790 PCI Expansion Drawer. It provides two HSL-2/RIO-G ports.</p> <p>Minimum operating system level: i5/OS V5R3 Supported on Models 520, 550, and 570. The #9531 is a Customer Install Feature.</p>
#9691	<p>#9691 Base Bus Adapter (Copper HSL) The #9691 is a base bus adapter card that installs in the #5074 PCI Expansion Tower and #5079 1.8 M I/O Tower, the #9079 Base I/O Tower or the #8079 Optional Base 1.8 M I/O Rack on a Model 840 system unit, and in the #0578/#5078 PCI Expansion Unit. The #9691 supports HSL Copper.</p> <p>Minimum operating system level: OS/400 V4R50 Supported on Models 810, 825, 870, 890. Customer Install Feature: n/a The #9691 is withdrawn from marketing as of 1 December 2005</p>
#9730	<p>#9730 Base HSL-2 Ports - 4 Copper The #9730 Base HSL-2 Ports - 4 Copper is a base 4-port copper HSL-2 bus adapter for Models 870 and 890. This adapter also has connectors for JTAG and CSP.</p> <p>Minimum operating system level: OS/400 V5R2 Supported on Models 870 and 890. The #9730 is a Customer Install Feature. The #9730 is withdrawn from marketing as of 01 October 2005.</p>
#9739	<p>#9739 Base Optical Bus Adapter The #9739 Base Optical Bus Adapter is used in the #5074 PCI Expansion Tower and #5079 1.8 M I/O Tower and in the #5078/#0578 to allow these towers to connect via optical HSL. The #9739 supports clustering (HSL OptiConnect).</p> <p>Minimum operating system level: OS/400 V5R1 or V5R2 when connected to Models 810, 825, 870, and 890 Supported on Models 825, 870, and 890. The #9739 is a Customer Install Feature.</p>
#9785	<p>#9785 Base HSL-2 Ports - 2 Copper The #9785 Base HSL-2 Ports - 2 Copper is a base 2-port copper HSL-2 adapter for the Model 825. The #9785 can be installed in either of the two HSL adapter slots (C08 or C09) on the Model 825 backplane. This feature can be ordered with a new Model 825 system unit on initial order or on model upgrade. If the system unit is already installed, order a #2785 HSL-2 Ports - 2 Copper for this function.</p> <p>Minimum operating system level: OS/400 V5R2 Supported on Model 825. The #9785 is a Customer Install Feature. The #9785 withdrawn from marketing as of 01 October 2005.</p>
#9786	<p>#9786 Base HSL Ports - 2 Optical The #9786 Base HSL Ports - 2 Optical is a base 2-port optical HSL adapter for the Model 825. The #9786 can be installed in either of the two HSL adapter slots (C08 or C09) on the Model 825 backplane. This feature can be ordered with a new Model 825 system unit on initial order or on model upgrade. If the system unit is already installed, order a #2786 HSL Ports - 2 Optical for this function.</p> <p>Minimum operating system level: OS/400 V5R2 Supported on Model 825. The #9786 is a Customer Install Feature. The #9786 withdrawn from marketing as of 01 October 2005</p>

#9787	<p>#9787 Base HSL-2 Ports - 2 Copper The #9787 Base HSL-2 Ports - 2 Copper board provides two copper HSL-2 ports. On the Model 825, the #9787 is attached to the processor board and does not plug into HSL adapter slots C08 or C09. Supported on Model 825 The #9787 is not a Customer Install Feature. The #9787 is withdrawn from marketing as of 01 June 2006.</p>
#9789	<p>#9789 Base HSL Ports - 4 Optical The #9789 Base HSL Ports - 4 Optical is a base 4-port optical HSL-2 bus adapter for the Model 890. This adapter also has connectors for JTAG and CSP. Minimum operating system level: OS/400 V5R2 Supported on Model 890. The #9789 is a Customer Install Feature.</p>
#9876	<p>#9876 Base Optical Bus Adapter The #9876 Base Optical Bus Adapter is a base feature which provides optical HSL connectivity with two HSL optical ports to support #0588/#5088, #0595/#5095, #5094, #5294, and #8294 expansion towers and expansion units. The #9876 is only available on initial orders.</p> <p>Migration of existing #9876s to eServer i5 servers is allowed. Existing #9876s are installed in migrated #5074, #5079, #5094, #5294, #0595, and #5095 expansion towers/units. The #9876 replaces the #9886 Base Optical Bus Adapter.</p> <p>Minimum operating system level: i5/OS V5R3 Supported on Models 550, 570, 595, 825, 870, and 890. The #9876 is a Customer Install Feature.</p>
#9877	<p>#9877 - Base HSL-2 Bus Adapter The #9877 - Base HSL-2 Bus Adapter is a base feature, which provides optical HSL-2/RIO-G connectivity with two HSL optical ports to support #0588/#5088 expansion towers and expansion units. The #9877 is only available on initial orders.</p> <p>Migration of existing #9877s to eServer i5 servers is allowed. Existing #9877s are installed in migrated #5074, #5079, #5094, #5294, #0595, and #5095 expansion towers or units. The #6417 is required on the #5088/#0588 when migrating to a Model 520, 550, 570, or 595. The #9877 replaces the #9887 Base HSL-2 Bus Adapter.</p> <p>Minimum operating system level: i5/OS V5R3 Supported on Models 520, 550, 570, and 595. The #9877 is a Customer Install Feature.</p>
#9886	<p>#9886 Base Optical Bus Adapter The #9886 Base Optical Bus Adapter provides optical HSL connectivity for the #5094, #0595/#5095, #0588/#5088 PCI, #5294, #8094 (top unit only), and #9094 expansion towers and expansion units. The #9886 can only be ordered with a new expansion tower or unit. If the expansion unit is already installed, order a #2886 for this function.</p> <p>Minimum operating system level: OS/400 V5R2 Supported on Models 825, 830, 840, 870, and 890. The #9886 is a Customer Install Feature. The #9886 is withdrawn from marketing as of 01 June 2006. A #9876 Base Optical Bus Adapter is the recommended replacement.</p>
#9887	<p>#9887 Base HSL-2 Bus Adapter The #9887 Base HSL-2 Bus Adapter provides HSL-2 connectivity for the #9094 Base PCI I/O Enclosure. The #9887 can only be ordered with a new expansion tower or unit. If the expansion unit is already installed, order a #2887 for this function. The #9887 is a Customer Install Feature. The #9887 is withdrawn from marketing as of 01 June 2006. A #9877 is the recommended replacement.</p>

4.3 i5/OS partitions on eServer p5 servers

i5/OS partitions on eServer p5 servers	
9411-100	<p>9411-100 eServer p5 I/O Subsystem for i5/OS</p> <p>The 9411-100 eServer p5 I/O Subsystem for i5/OS provides the I/O for any i5/OS partitions running on a 1.65 GHz eServer p5. It is provided as machine type/model 9411-100 with prices, warranty and service identical to that provided for the same I/O features on a 9406 Model 570, 590 or 595. The 9411-100 eServer p5 I/O Subsystem for i5/OS is supported on the following eServer p5 models:</p> <ul style="list-style-type: none"> ▶ The 1.65 GHz 9117 570 supports one processor worth of i5/OS workload. ▶ The 1.65 GHz 9119 590 and 595 supports up to two processors worth of i5/OS workload. <p>i5/OS is required for each processor.</p> <p>Minimum operating system level: i5/OS V5R3</p> <p>For additional information, see <i>IBM eServer i5 and iSeries System Handbook i5/OS Version 5 Release 3 October 2005 - Draft</i>, GA19-5486, and the IBM eServer i5 and iSeries planning Web site (under Language → V5R3 → Planning) at: http://www.ibm.com/eserver/series/infocenter</p>

4.4 Models 825, 870, and 890 Capacity on Demand

Models 825, 870 and 890 Capacity On Demand	
#1609	<p>#1609 825 CUoD Activation</p> <p>The #1609 825 CUoD Activation is used to order a password to activate one additional processor on the Model 825 with a CUoD processor feature. Up to three #1609s can be ordered on initial orders or via MES to activate additional processors.</p> <p>Minimum operating system level: OS/400 V5R2</p> <p>Supported on the #2473 Model 825 3/6-way processor.</p>
#1610	<p>#1610 890 CUoD Activation</p> <p>The #1610 890 CUoD Activation is used to order a password to activate one additional processor on the Model 890 with a CUoD processor. Up to eight #1610s can be ordered on initial orders or via MES to activate additional processors.</p> <p>Minimum operating system level: OS/400 V5R2</p> <p>Supported on the #2487 Model 890 16/24-way Processor and #2488 Model 890 24/32-way Processor</p>
#1611	<p>#1611 870 CUoD Activation</p> <p>The #1611 870 CUoD Activation is used to order a password to activate one additional processor on a Model 870 with a CUoD processor. Up to eight #1611s can be ordered on initial orders or via MES to activate additional processors.</p> <p>Minimum operating system level: OS/400 V5R2</p> <p>Supported on the #2486 Model 870 8/16-way Processor.</p>
#1612	<p>#1612 890 CUoD Activation</p> <p>The #1612 890 CUoD Activation is used to order a password to activate one additional processor on a Model 890 with a CUoD processor. Up to eight #1612s can be ordered on initial orders or via MES to activate additional processors.</p> <p>Minimum operating system level: OS/400 V5R2</p> <p>Supported on the #2497 Model 890 16/24-way Processor.</p>
#1613	<p>#1613 890 CUoD Activation</p> <p>The #1613 890 CUoD Activation is used to order a password to activate one additional processor on a Model 890 with a CUoD processor. Up to eight #1613s can be ordered on initial orders or via MES to activate additional processors.</p> <p>Minimum operating system level: OS/400 V5R2</p> <p>Supported on the #2498 Model 890 16/24-way Processor.</p>
#1614	<p>#1614 870 CUoD Activation</p> <p>The #1614 870 CUoD Activation is used to order a password to activate one additional processor on a Model 870 with a CUoD processor. Up to three #1614s can be ordered on initial orders or via MES to activate additional processors.</p> <p>Minimum operating system level: OS/400 V5R2</p> <p>Supported on the #2489 Model 870 5/8-way Processor.</p>

#1682	<p>#1682 On/Off Prepaid for Model 825 The #1682 On/Off Prepaid for Model 825 Standard Edition provides an account for 30 processor days of On/Off Capacity on Demand. The system must be enabled for On/Off Capacity on Demand before ordering prepaid days.</p> <p>Minimum operating system level: OS/400 V5R2 Supported on the #2473 Model 825 3/6-way Processor with #1773 TCoD Enablement.</p>
#1683	<p>#1683 On/Off Prepaid for Model 825 The #1683 On/Off Prepaid for Model 825 Enterprise Edition provides an account for 30 processor days of On/Off Capacity on Demand. The system must be enabled for On/Off Capacity on Demand before ordering prepaid days.</p> <p>Minimum operating system level: OS/400 V5R2 Supported on the #2473 Model 825 3/6-way Processor with #1773 TCoD Enablement.</p>
#1684	<p>#1684 On/Off Prepaid for Model 870 The #1684 On/Off Prepaid for Model 870 Standard Edition provides an account for 30 processor days of On/Off Capacity on Demand. The system must be enabled for On/Off Capacity on Demand before ordering prepaid days.</p> <p>Minimum operating system level: OS/400 V5R2 Supported on the #2489 Model 870 5/8-way Processor with #1774 TCoD Enablement.</p>
#1685	<p>#1685 On/Off Prepaid for Model 870 The #1685 On/Off Prepaid for Model 870 Standard Edition provides an account for 30 processor days of On/Off Capacity on Demand. The system must be enabled for On/Off Capacity on Demand before ordering prepaid days.</p> <p>Minimum operating system level: OS/400 V5R2 Supported on the #2486 Model 870 8/16-way Processor with #1776 TCoD Enablement.</p>
#1686	<p>#1686 On/Off Prepaid for Model 870 The #1686 On/Off Prepaid for Model 870 Enterprise Edition provides an account for 30 processor days of On/Off Capacity on Demand. The system must be enabled for On/Off Capacity on Demand before ordering prepaid days.</p> <p>Minimum operating system level: OS/400 V5R2 Supported on the #2486 Model 870 8/16-way Processor with #1776 TCoD Enablement.</p>
#1688	<p>#1688 On/Off Prepaid for Model 890 The #1688 On/Off Prepaid for Model 890 Standard Edition provides an account for 30 processor days of On/Off Capacity on Demand. The system must be enabled for On/Off Capacity on Demand before ordering prepaid days.</p> <p>Minimum operating system level: OS/400 V5R2 Supported on the #2497 Model 890 16/24-way Processor with #1777 TCoD Enablement.</p>
#1689	<p>#1689 On/Off Prepaid for Model 890 The #1689 On/Off Prepaid for Model 890 Enterprise Edition provides an account for 30 processor days of On/Off Capacity on Demand. The system must be enabled for On/Off Capacity on Demand before ordering prepaid days.</p> <p>Minimum operating system level: OS/400 V5R2 Supported on the #2497 Model 890 16/24-way Processor with #1777 TCoD Enablement.</p>
#1691	<p>#1691 On/Off Prepaid for Model 890 The #1691 On/Off Prepaid for Model 890 Standard Edition provides an account for 30 processor days of On/Off Capacity on Demand. The system must be enabled for On/Off Capacity on Demand before ordering prepaid days.</p> <p>Minimum operating system level: OS/400 V5R2 Supported on the #2498 Model 890 24/32-way Processor with #1778 TCoD Enablement.</p>
#1692	<p>#1692 On/Off Prepaid for Model 890 The #1692 On/Off Prepaid for Model 890 Enterprise Edition provides an account for 30 processor days of On/Off Capacity on Demand. The system must be enabled for On/Off Capacity on Demand before ordering prepaid days.</p> <p>Minimum operating system level: OS/400 V5R2 Supported on the #2498 Model 890 24/32-way Processor with #1778 TCoD Enablement.</p>
#1695	<p>#1695 On/Off Prepaid for Model 870 The #1695 On/Off Prepaid for Model 870 Enterprise Edition provides an account for 30 processor days of On/Off Capacity on Demand. The system must be enabled for On/Off Capacity on Demand before ordering prepaid days.</p> <p>Minimum operating system level: OS/400 V5R2 Supported on the #2489 Model 870 5/8-way Processor with #1774 TCoD Enablement.</p>

#1697	<p>#1697 On/Off Prepaid for Model 825</p> <p>The #1697 On/Off Prepaid for Model 825 CBU Edition provides an account for 30 processor days of On/Off Capacity on Demand. The system must be enabled for On/Off Capacity on Demand before ordering prepaid days.</p> <p>Minimum operating system level: OS/400 V5R2</p>
#1698	<p>#1698 On/Off Prepaid for Model 870</p> <p>The #1698 On/Off Prepaid for Model 870 CBU Edition provides an account for 30 processor days of On/Off Capacity on Demand. The system must be enabled for On/Off Capacity on Demand before ordering prepaid days.</p> <p>Minimum operating system level: OS/400 V5R2</p> <p>Supported on Models 520, 550, 570, 595, and 9411-100.</p> <p>Supported on the #2496 Model 870 2/16-way Processor with #1780 TCoD Enablement</p> <p>Supported on the #2495 Model 825 1/6-way Processor with #1779 TCoD Enablement.</p>
#1699	<p>#1699 On/Off Prepaid for Model 890</p> <p>The #1699 On/Off Prepaid for Model 890 CBU Edition provides an account for 30 processor days of On/Off Capacity on Demand. The system must be enabled for On/Off Capacity on Demand before ordering prepaid days.</p> <p>Minimum operating system level: OS/400 V5R2</p> <p>Supported on the #2499 Model 890 4/32-way Processor with #1781 TCoD Enablement.</p>
#177x	<p>#177x On/Off Capacity on Demand (enablement)</p> <p>A #177x feature code is used to enable On/Off Capacity on Demand by providing a password to be installed on an iSeries server. After this password is installed, unused On/Off Capacity on Demand processors can be activated. A limit of 192 processor days can be used on a temporary basis.</p> <p>Requires a contract to be signed before the #177x feature is ordered. On/Off Capacity on Demand processor usage must be reported on, minimally, a monthly basis to IBM or the client's Business Partner. A #178x or #179x On/Off Capacity on Demand billing feature initiates quarterly invoices based on the number of processor days used. A new contract can be signed and the #177x feature reordered as the limit of usable temporary processor days approaches.</p> <p>Supported feature codes by model are:</p> <ul style="list-style-type: none"> ▶ #1773 TCoD Enablement for Model 825 ▶ #1774 TCoD Enablement for Model 870 ▶ #1776 TCoD Enablement for Model 870 ▶ #1777 TCoD Enablement for Model 890 ▶ #1778 TCoD Enablement for Model 890 ▶ #1779 TCoD Enablement for Model 825 ▶ #1780 TCoD Enablement for Model 870 ▶ #1781 TCoD Enablement for Model 890

<p>#178x #179x</p>	<p>#178x-#179x On/Off Capacity on Demand Billing A #178x-#179x feature code is used for On/Off Capacity on Demand billing. After a #177x On/Off Capacity on Demand feature is ordered and the associated password is installed on the system, the user must report monthly to IBM their On/Off Capacity on Demand usage. This information is used to compute the On/Off Capacity on Demand billing. One On/Off Capacity on Demand billing feature is required for each processor day that is used for temporary capacity.</p> <p>There is a limit to the number of processor days that are agreed to in the contract that was signed prior to ordering the On/Off Capacity on Demand feature. To continue using temporary capacity after the initial limit has been reached, a new contract is required and a second On/Off Capacity on Demand feature is ordered. An On/Off Capacity on Demand feature cannot be concurrently ordered with an On/Off Capacity on Demand billing feature.</p> <ul style="list-style-type: none"> ▶ #1782 TCoD Billing for Model 825 Prerequisites: #1773 TCoD Enablement for Model 825, #7416 Standard Edition ▶ #1783 TCoD Billing for Model 825 Prerequisites: #1773 TCoD Enablement for Model 825, #7418 Enterprise Edition ▶ #1784 TCoD Billing for Model 870 Prerequisites: #1774 TCoD Enablement for Model 870, #7431 Standard Edition ▶ #1785 TCoD Billing for Model 870 Prerequisites: #1776 TCoD Enablement for Model 870, #7419 Standard Edition ▶ #1786 TCoD Billing for Model 870 Prerequisites: #1776 TCoD Enablement for Model 870, #7421 Enterprise Edition ▶ #1788 TCoD Billing for Model 890 Prerequisites: #1777 TCoD Enablement for Model 890, #7422 Standard Edition ▶ #1789 TCoD Billing for Model 890 Prerequisites: #1777 TCoD Enablement for Model 890, #7424 Enterprise Edition ▶ #1791 TCoD Billing for Model 890 Prerequisites: #1778 TCoD Enablement for Model 890, #7425 Standard Edition ▶ #1792 TCoD Billing for Model 890 Prerequisites: #1778 TCoD Enablement for Model 890, #7427 Enterprise Edition ▶ #1795 TCoD Billing for Model 870 Prerequisites: #1774 TCoD Enablement for Model 870, #7433 Enterprise Edition ▶ #1797 TCoD Billing for Model 825 Prerequisites: #1779 TCoD Enablement for Model 825, #7439 Capacity BackUp Edition ▶ #1798 TCoD Billing for Model 870 Prerequisites: #1780 TCoD Enablement for Model 870, #7440 Capacity BackUp Edition ▶ #1799 TCoD Billing for Model 890 Prerequisites: #1781 TCoD Enablement for Model 890, #7444 Capacity BackUp Edition
<p>#9603</p>	<p>#9603 Base CUoD Activation The #9603 Base CUoD Activation feature is used to activate one additional processor with a CUoD feature as part of an initial order on Models 870 and 890 Enterprise Editions. The #9603 is withdrawn from marketing as of 01 October 2005.</p>

4.5 Main storage

Main storage	
Base	There is no base memory on Models 520, 550, 570 595, 800, 810, 825, 870, and 890.
Model 520+ Main Memory Rules	<p>Memory features for the Model 520 with #8325, #8327 and #8330 processors</p> <ul style="list-style-type: none"> ▶ #4400 - 1 GB DDR2 Main Storage (2 x 512 MB DIMMs: 533 MHz sdram CCIN 313A) ▶ #4474 - 2 GB DDR2 Main Storage (2 x 1 GB DIMMs: 533 MHz sdram CCIN 313B) ▶ #4475 - 4 GB DDR2 Main Storage (2 x 2 GB DIMMs: 533 MHz sdram CCIN 313D) ▶ #4477 - 8 GB DDR2 Main Storage (2 x 4 GB DIMMs: 533 MHz sdram CCIN 313E) <p>Requires a minimum of one pair of DIMMs on all processors. DIMMs must be installed in sets of two (pairs). For 9405 and 9406 processors, the first DIMM pair goes into DIMM slots J0A & J2A. The second pair of DIMMs goes into slots J0C & J2C, the third pair goes into DIMM slots J0B & J2B and the fourth pair goes into DIMM slots J0D & J2D.</p>

<p>Model 520 Main Memory Rules</p>	<p>Memory features for the Model 520</p> <ul style="list-style-type: none"> ▶ #3093 - 512 MB Main Storage DIMM (DDR; 256 Mb technology, unstacked, CCIN 3093) (9406 Model 520 only) ▶ #3094 - 1 GB Main Storage DIMM (DDR; 256 Mb technology, stacked, CCIN 3094) (9406 Model 520 only) ▶ #3096 - 2 GB Main Storage DIMM (DDR; 256 Mb technology, stacked, CCIN 3096) (9406 Model 520 only) ▶ #4443 - 512 MB DDR Main Storage (DDR1; 256 Mb technology, CCIN 309B) ▶ #4444 - 1 GB DDR Main Storage (DDR1; 256 Mb technology, CCIN 309B) (ships four 256 MB DIMMs for a total of 1 GB) ▶ #4445 - 4 GB DDR Main Storage (DDR1; 128 Mb technology, CCIN 30D3) (ships four 1 GB DIMMs for a total of 4 GB) ▶ #4447 - 2 GB DDR Main Storage (DDR1; 64 Mb technology, CCIN 30D2) (ships four 512 MB DIMMs for a total of 2 GB) ▶ #4449 - 8 GB DDR Main Storage (DDR1; 128 Mb technology, stacked, CCIN 30D5) (ships four 2 GB DIMMs for a total of 8 GB) ▶ #4450 - 16 GB DDR Main Storage (DDR1; 1 Gb technology, stacked, CCIN 30AC) (ships four 4 GB DIMMs for a total of 16 GB) <p>Install DIMMs in sets of four (quads) with one exception: A single pair of 256 MB DIMMs is allowed on the #8950 processor. Add an additional pair of 256 MB DIMMs to the original pair (to make a quad) whenever more DIMMs are added. Then one additional quad of DIMMs can be added to the system. For the #8950 processor, the first DIMM pair goes into DIMM slots J0A and J2A. The second pair of DIMMs goes into slots J0C and J2C. The first quad of DIMMs is plugged into DIMM slots J0A, J2A, J0C, and J2C. The second quad of DIMMs is plugged into DIMM slots J0B, J2B, J0D, and J2D.</p>
<p>Model 550+ Main Memory Rules</p>	<p>Memory features for the Model 550 with #8312 processors</p> <ul style="list-style-type: none"> ▶ #4400 - 1 GB DDR2 Main Storage (2 x 512 MB DIMMs: 533 MHz sdram CCIN 313A) ▶ #4474 - 2 GB DDR2 Main Storage (2 x 1 GB DIMMs: 533 MHz sdram CCIN 313B) ▶ #4475 - 4 GB DDR2 Main Storage (2 x 2 GB DIMMs: 533 MHz sdram CCIN 313D) ▶ #4477 - 8 GB DDR2 Main Storage (2 x 4 GB DIMMs: 533 MHz sdram CCIN 313E) <p>The Model 550+ has two x #8312 processor cards. A minimum of one memory feature (one pair of DIMMs) is required on each processor card. DIMMs must be installed in sets of two (pairs). The Model 550+ requires a minimum of 2 GB memory.</p>
<p>Model 550 Main Memory Rules</p>	<p>Memory features for the Model 550</p> <ul style="list-style-type: none"> ▶ #3093 - 512 MB Main Storage (DIMM; DDR 256 Mb technology) ▶ #3094 - 1 GB Main Storage (DIMM; DDR 256 Mb technology) ▶ #3096 - 2 GB Main Storage (DIMM; DDR 256 Mb technology) ▶ #4444 - 1 GB DDR Main Storage (DDR1; 256 Mb technology, CCIN 309B) (ships four 256 MB DIMMs for a total of 1 GB) ▶ #4445 - 4 GB DDR Main Storage (DDR1; 128 Mb technology, CCIN 30D3) (ships four 1 GB DIMMs for a total of 4 GB) ▶ #4447 - 2 GB DDR Main Storage (DDR1; 64 Mb technology, CCIN 30D2) (ships four 512 MB DIMMs for a total of 2 GB) ▶ #4449 - 8 GB DDR Main Storage (DDR1; 128 Mb technology, stacked, CCIN 30D5) (ships four 2 GB DIMMs for a total of 8 GB) ▶ #4450 - 16 GB DDR Main Storage (DDR1; 1 Gb technology, stacked, CCIN 30AC) (ships four 4 GB DIMMs for a total of 16 GB) <p>Install DIMMs in sets of four (quads). When one processor card is used, the DIMMs are installed in the following sequence:</p> <ul style="list-style-type: none"> ▶ The first quad of DIMMs is plugged into DIMM slots J0A, J0B, J0C, and J0D ▶ The second quad of DIMMs is plugged into DIMM slots J1A, J1B, J1C, and J1D. <p>When two processor cards are used, the DIMMs are installed in following sequence:</p> <ul style="list-style-type: none"> ▶ The first quad of DIMMs is plugged into DIMM slots J0A, J0B, J0C, and J0D of the first processor card. ▶ The second quad of DIMMs is plugged into DIMM slots J0A, J0B, J0C, and J0D of the second processor card. ▶ The third quad of DIMMs is plugged into DIMM slots J1A, J1B, J1C, and J1D of the second processor card. ▶ The fourth quad of DIMMs is plugged into DIMM slots J1A, J1B, J1C, and J1D of the first processor card.

Model 570+ Main Memory Rules	<p>Memory features for the IBM System i5 570+</p> <ul style="list-style-type: none"> ▶ #7892 - 2 GB DDR2 Main Storage provides 2 GB of MS and consists of four 512 MB DDR2 DIMMs. (CCIN 30F0) ▶ #7893 - 4 GB DDR2 Main Storage provides 4 GB of MS and consists of four 1 GB DDR2 DIMMs. (CCIN 30F2) ▶ #7894 - 8 GB DDR2 Main Storage provides 8 GB of MS and consists of four 2 GB DDR2 DIMMs. (CCIN 30F3) ▶ #4495 - 4/8 GB CUoD DDR2 Main Storage provides 4 GB of activated and additional 4 GB of DDR2 memory available for activation with four 2 GB DIMMs. (CCIN 316F) The 4 GB of additional memory can be activated in increments of 1 GB. If a memory feature is moved to a different system, that system recognizes only 4 GB as available unless additional memory activations are acquired or already present on that server. For the original system, four 1 GB memory activations remain and can be used for other CUoD memory features. For special situations, contact IBM CoD administration about transferring memory activations between systems. ▶ #4496 - 8/16 GB CUoD DDR2 Main Storage provides 8 GB of activated DDR2 and additional 8 GB of DDR2 memory available for activation with four 4 GB DIMMs. (CCIN 314E)The 8 GB of additional memory can be activated in increments of 1 GB. If a memory feature is moved to a different server, that server recognizes only 8 GB as available unless additional memory activations are acquired or already present on that server. For the original server, eight 1 GB memory activations remain and can be used for other CUoD memory features. For special situations, contact IBM CoD administration about transferring memory activations between servers. ▶ #4497 - 16 GB DDR2 Main Storage provides 16 GB of MS and consists of four 4 GB DDR2 DIMMs. (CCIN 312F) ▶ #4498 - 32 GB DDR2 Main Storage provides 32 GB of MS and consists of four 8 GB DDR2 DIMMs. (CCIN 314C) The #4498 is comprised of 400 MHz DDR2 DIMMs and cannot be mixed with other Model 570 memory on the same processor card. #4498 can be mixed with other DDR2 memory in the same enclosure or in the same system. ▶ #7663 - 570 1 GB Memory Activation provides the activation of 1 GB of additional Capacity on Demand memory. Multiple #7663 features are allowed up to the maximum CUoD memory of the server. Memory activations are stored in the server. If CUoD memory is moved to a different server, the additional activations remain with the original server. <p>The System 570+ offers pluggable DIMMs for memory. Each feature above ships four DDR2 Dimms. There is a minimum of two memory features per processor enclosure. 2/4-way = minimum 2, maximum 4; 4/8-way = minimum 4, maximum 8; 8/16-way = minimum 8, maximum 16 The minimum memory for a 2/4-way 570+ is 4 GB, for a 4/8-way it is 8 GB and for the 8/16-way it is 16 GB. The maximum memory capacity depends upon the number of processors ordered for the system and on the type of memory and functionality required.</p> <p>The rules for mixing and matching DIMMs are:</p> <ul style="list-style-type: none"> ▶ Install memory DIMMs in quads. ▶ Quads must be the same DIMM. ▶ Memory balancing and spreading is required.
---------------------------------------	--

Model 570 Main Memory Rules	<p>Memory features for the Model 570</p> <ul style="list-style-type: none"> ▶ #3043 - 512 MB Main Storage DIMM (DDR; 256 Mb technology, unstacked, CCIN 3043) ▶ #3044 - 1 GB Main Storage DIMM (DDR; 256 Mb technology, stacked, CCIN 3044) ▶ #3046 - 2 GB Main Storage DIMM (DDR; 256 Mb technology, stacked, CCIN 3046) ▶ #4452 - 2 GB DDR Main Storage (DDR1 CCIN 309D) (ships four 512 MB DIMMs for a total of 2 GB) ▶ #4454 - 8 GB DDR Main Storage (DDR1 CCIN 30AA) (ships four 2 GB DIMMs for a total of 8 GB) ▶ #4490 - 4 GB DDR Main Storage (DDR1 CCIN 309E) (ships four 1 GB DIMMs for a total of 4 GB) ▶ #4491 - 16 GB DDR Main Storage (DDR1 CCIN 30B3) (ships four 4 GB DIMMs for a total of 16 GB) ▶ #4492 - 32 GB DDR Main Storage (DDR1 CCIN 30F7) (ships four 8 GB DIMMs for a total of 32 GB) (#8971 Processor only). Must be installed on a processor card by itself or with another #4492 or with features #4494 or #7049. ▶ #4494 - 16 GB Main Storage (ships four 4 GB DIMMs for a total of 16 GB) Must be installed on a processor card by itself or with another #4494 or with features #4492 or #7049. ▶ #7049 - 8/16 GB DDR-1 Main Storage: Provides 8 GB of activated memory and an additional 8 GB of memory available for activation. The 8 GB of additional memory can be activated in increments of 1 GB. #7049 must be installed on a processor card either by itself or with another #7049 or with features #4492 or #4494. <p>The Model 570 offers pluggable DIMMs for memory. Each 0/2-way processor card contains eight slots for up to eight pluggable DIMMs. The minimum memory for a for a Model 570 is 2 GB. The maximum memory capacity depends upon the number of processors ordered for the system and on the type of memory and functionality required.</p> <p>The rules for mixing and matching DIMMs are:</p> <ul style="list-style-type: none"> ▶ Install memory DIMMs in quads. ▶ Quads must be the same DIMM. ▶ Memory balancing and spreading is required. <p>For the #0931 1/2-way server, DIMMs are installed in the following sequence:</p> <ul style="list-style-type: none"> ▶ The first quad of DIMMs is plugged into DIMM slots J0A, J0C, J1A, and J1C. ▶ The second quad of DIMMs is plugged into DIMM slots J0B, J0D, J1B, and J1D. <p>For the #0921 2/4-way server, DIMMs are installed in the following sequence:</p> <ul style="list-style-type: none"> ▶ Enclosure 1, Processor Card 1: Slots J0A, J0C, J1A, and J1C ▶ Enclosure 1, Processor Card 2: Slots J0A, J0C, J1A, and J1C ▶ Enclosure 1, Processor Card 2: Slots J0B, J0D, J1B, and J1D ▶ Enclosure 1, Processor Card 1: Slots J0B, J0D, J1B, and J1D <p>For the #0923 5/8-way server, DIMMs are installed in the following sequence:</p> <ul style="list-style-type: none"> ▶ Enclosure 1, Processor Card 1: Slots J0A, J0C, J1A, and J1C ▶ Enclosure 1, Processor Card 2: Slots J0A, J0C, J1A, and J1C ▶ Enclosure 2, Processor Card 3: Slots J0A, J0C, J1A, and J1C ▶ Enclosure 2, Processor Card 4: Slots J0A, J0C, J1A, and J1C ▶ Enclosure 2, Processor Card 4: Slots J0B, J0D, J1B, and J1D ▶ Enclosure 2, Processor Card 3: Slots J0B, J0D, J1B, and J1D ▶ Enclosure 1, Processor Card 2: Slots J0B, J0D, J1B, and J1D ▶ Enclosure 1, Processor Card 1: Slots J0B, J0D, J1B, and J1D <p>For the #0925 9/12-way server, DIMMs are installed in the following sequence:</p> <ul style="list-style-type: none"> ▶ Enclosure 1, Processor Card 1: Slots J0A, J0C, J1A, and J1C ▶ Enclosure 1, Processor Card 2: Slots J0A, J0C, J1A, and J1C ▶ Enclosure 2, Processor Card 3: Slots J0A, J0C, J1A, and J1C ▶ Enclosure 2, Processor Card 4: Slots J0A, J0C, J1A, and J1C ▶ Enclosure 3, Processor Card 5: Slots J0A, J0C, J1A, and J1C ▶ Enclosure 3, Processor Card 6: Slots J0A, J0C, J1A, and J1C ▶ Enclosure 3, Processor Card 6: Slots J0B, J0D, J1B, and J1D ▶ Enclosure 3, Processor Card 5: Slots J0B, J0D, J1B, and J1D ▶ Enclosure 2, Processor Card 4: Slots J0B, J0D, J1B, and J1D ▶ Enclosure 2, Processor Card 3: Slots J0B, J0D, J1B, and J1D ▶ Enclosure 1, Processor Card 2: Slots J0B, J0D, J1B, and J1D ▶ Enclosure 1, Processor Card 1: Slots J0B, J0D, J1B, and J1D
--------------------------------------	---

<p>Model 570 Main Memory Rules (cont.)</p>	<p>Memory features for the Model 570</p> <p>For the #0927 13/16-way server, DIMMs are installed in the following sequence:</p> <ul style="list-style-type: none"> ▶ Enclosure 1, Processor Card 1: Slots J0A, J0C, J1A, and J1C ▶ Enclosure 1, Processor Card 2: Slots J0A, J0C, J1A, and J1C ▶ Enclosure 2, Processor Card 3: Slots J0A, J0C, J1A, and J1C ▶ Enclosure 2, Processor Card 4: Slots J0A, J0C, J1A, and J1C ▶ Enclosure 3, Processor Card 5: Slots J0A, J0C, J1A, and J1C ▶ Enclosure 3, Processor Card 6: Slots J0A, J0C, J1A, and J1C ▶ Enclosure 4, Processor Card 7: Slots J0A, J0C, J1A, and J1C ▶ Enclosure 4, Processor Card 8: Slots J0A, J0C, J1A, and J1C ▶ Enclosure 4, Processor Card 8: Slots J0B, J0D, J1B, and J1D ▶ Enclosure 4, Processor Card 7: Slots J0B, J0D, J1B, and J1D ▶ Enclosure 3, Processor Card 6: Slots J0B, J0D, J1B, and J1D ▶ Enclosure 3, Processor Card 5: Slots J0B, J0D, J1B, and J1D ▶ Enclosure 2, Processor Card 4: Slots J0B, J0D, J1B, and J1D ▶ Enclosure 2, Processor Card 3: Slots J0B, J0D, J1B, and J1D ▶ Enclosure 1, Processor Card 2: Slots J0B, J0D, J1B, and J1D ▶ Enclosure 1, Processor Card 1: Slots J0B, J0D, J1B, and J1D <p>Each processor feature should have at least one memory feature associated with it.</p> <p>Memory spreading and balancing: Performance measurements have determined that optimal performance requires both spreading of memory across processors and balancing memory across processors. Use the following rules for Model 570 memory.</p> <ul style="list-style-type: none"> ▶ Memory minimums: Each processor card must have at least one set of memory DIMM placed on it. Memory is in feature codes of quads. ▶ Balancing: Each 0/2-way processor card must have a minimum of 2 GB memory on it. ▶ Spreading: Spread memory across the processor cards. Select memory DIMMs to enable equal memory configurations across processors in a n-way unit. If memory greater than the minimum is ordered, base the selection of memory features on driving the most number of DIMM quads onto the system, as evenly distributed across the processors as possible.
<p>Model 595 Main Memory Rules</p>	<p>Memory features for the Model 595</p> <ul style="list-style-type: none"> ▶ #7816 CUoD 2/4 GB (4 X 1 GB), DDR1, 512 Mb, 266 MHZ, DRAM DIMMS ▶ #7828 16 GB (4 X 4 GB), DDR1 1 Gb, 266 MHZ, DRAM DIMMS ▶ #7829 32 GB (4 X 4 GB), DDR1 1 Gb, 266 MHZ, DRAM DIMMS ▶ #7835 CUoD 4/8 GB (4 X 2 GB), DDR1 512 Mb, 266 MHZ, DRAM DIMMS <p>Memory rules:</p> <ul style="list-style-type: none"> ▶ The minimum memory requirements are four feature codes (two pairs) per node with 16 GB per node. ▶ Memory must be ordered in identical pairs. ▶ Each node #8981 has 16 memory slots. There can be up to four nodes in a system. ▶ Memory is spread out in identical pairs per MCM ▶ Only one increment difference is allowed in memory size within a node. This means that 4 and 8, 8 and 16, 16 and 32 GB increments in a node are allowed, but 4 and 16/4 and 32/8 in a node are not allowed. ▶ The #7799 requires #7835 x 64. ▶ The #7970 requires at least one #7816 or #7835. ▶ The #7976 requires at least one #7828 or #7829. <p>Placement rules:</p> <ul style="list-style-type: none"> ▶ Memory must be placed in pairs. ▶ The placement sequence is: <ul style="list-style-type: none"> – Fill slots 1 and 2 first starting with Node 1, 2, 3 then 4, (2) – Fill slots 3 and 4 starting with Node 1, 2, 3 then 4 (3) – Fill slots 5 and 6 starting with Node 1, 2, 3 then 4, (4) – Fill slots 8 and 9 starting with Node 1, 2, 3 then 4 (5) – Fill slots 12 and 13 starting with Node 1, 2, 3 then 4 (6) – Fill slots 7 and 10 slots starting with Node 1, 2, 3 then 4 (7) – Fill 11 and 14 slots starting with Node 1, 2, 3 then 4. ▶ Nodes 1, 2, 3 and 4 are placed left to right as viewed from the front.

Model 800 Main Memory Rules	<p>Memory features for the Model 800 #2463 and #2464 processors:</p> <ul style="list-style-type: none"> ▶ #3092 - 256 MB Main Storage DIMM (DDR - 128 Mb technology, unstacked) ▶ #3093 - 512 MB Main Storage DIMM (DDR - 256 Mb technology, unstacked) ▶ #3094 - 1 GB Main Storage DIMM (DDR - 256 Mb technology, stacked) ▶ #3096 - 2 GB Main Storage DIMM (DDR - 256 Mb technology, stacked) <p>A single main storage DIMM feature is allowed on Model 800 processors.</p> <p>When the total number of main storage DIMMs is increased greater than one, the single existing DIMM must be paired up with a DIMM of the same capacity. Any additional DIMMs must be added in pairs of the same capacity.</p> <p>Eight memory DIMM slots are available in the base system for main storage DIMMs, which plug directly onto the backplane.</p>
Model 810 Main Memory Rules	<p>Memory features for the Model 810 #2465, #2466, and #2467 processors</p> <ul style="list-style-type: none"> ▶ #3092 - 256 MB Main Storage DIMM (DDR - 128 Mb technology, unstacked) ▶ #3093 - 512 MB Main Storage DIMM (DDR - 256 Mb technology, unstacked) ▶ #3094 - 1 GB Main Storage DIMM (DDR - 256 Mb technology, stacked) ▶ #3096 - 2 GB Main Storage DIMM (DDR - 256 Mb technology, stacked) <p>A single main storage DIMM feature is allowed on Model 810 processors.</p> <p>When the total number of main storage DIMMs is increased greater than one, the single existing DIMM must be paired up with a DIMM of the same capacity. Any additional DIMMs must be added in pairs of the same capacity.</p> <p>Eight memory DIMM slots are available in the base system for main storage DIMMs which plug directly onto the backplane.</p> <p>Memory features for the Model 810 #2469 processor</p> <p>There are 16 DIMM memory positions on the memory riser card (CCIN 2884), and all memory plugs into this card:</p> <ul style="list-style-type: none"> ▶ #3022 - 128 MB Main Storage (64 Mb technology): Support only, orderable up to the minimum number of DIMMs required to meet a pair or quad system memory requirement. ▶ #3024 - 256 MB Main Storage (128 Mb technology) (unstacked) ▶ #3025 - 512 MB Main Storage (128 Mb technology) (stacked): The #3025 cannot be mixed with the #3026 for pairs or quads. ▶ #3026 - 512 MB Main Storage (256 Mb technology) (unstacked): The #3026 cannot be mixed with the #3025 for pairs or quads. ▶ #3027 - 1 GB Main Storage (256 Mb technology) (stacked) ▶ #3029 - 128 MB Main Storage (128 Mb technology) (unstacked): The #3029 cannot be mixed with the #3022 for pairs or quads. <p>A maximum of eight #3029 DIMM features is allowed on a system.</p> <p>A minimum of two DIMMs (same feature code) must be selected. If more than two DIMMs are required, all memory features must be in sets of four (quads) of the same feature code. This means a quad must also be made out of the initial two DIMMs.</p>

<p>Model 825 Main Memory Rules</p>	<p>Memory features for the Model 825: The following memory features are available on the Model 825:</p> <ul style="list-style-type: none"> ▶ #3042 - 256 MB Main Storage DIMM (default 4 x 256 MB) (DDR - 128 Mb technology, unstacked) ▶ #3043 - 512 MB Main Storage DIMM (DDR - 256 Mb technology, unstacked) ▶ #3044 - 1024 MB Main Storage DIMM (DDR - 256 Mb technology, stacked) ▶ #3046 - 2048 MB Main Storage DIMM (DDR - 512 Mb technology, stacked) <p>For the Model 825, the main storage DIMMs are installed directly onto the processor cards. Each processor card has eight DIMM slots. The eight slots are arranged in two sets of four. The DIMMs must be installed in sets of four (quads). Each set of four DIMMs must be the same memory capacity and technology. Each system order must have at least three sets of four main storage DIMMs (quad installed (twelve DIMMs total). The exception is the 2 GB memory capacity where two quads (8 DIMMs total) are allowed.</p> <p>There is a total of 24 DIMM slots in which 8, 12, 16, 20, or 24 memory DIMMs can be installed.</p> <p>Except on systems with 2 GB of memory capacity, no processor is allowed to contain more than twice the memory capacity of any other processor. The IBM marketing configurator determines the correct quantity and correct card capacities for valid system configurations based on the total amount of memory desired.</p> <p>On systems with 2 GB of memory, the IBM marketing configurator issues a message informing the user that IBM does not recommend operating a system with this memory configuration.</p> <p>The sequence for plugging memory DIMMs for processor #2473 is:</p> <ul style="list-style-type: none"> ▶ Fill four slots on the first processor card. ▶ Then fill four slots on the second processor card. ▶ Then fill four slots on the third processor card. ▶ Then start again with the first processor card filling four slots.
<p>Model 870 Main Memory Rules</p>	<p>Memory features for the Model 870: The following memory features are available on the Model 870:</p> <ul style="list-style-type: none"> ▶ #3020 - 4096 MB Main Storage Card (inside): Plugs into memory card slots 0, 1, 2, and 3 ▶ #3015 - 8192 MB Main Storage Card (inside): Plugs into memory card slots 0, 1, 2, and 3 ▶ #3035 - 16384 MB Main Storage Card (inside): Plugs into memory card slots 0, 1, 2, and 3 ▶ #3017 - 32768 MB Main Storage Card (inside): Plugs into memory card slots 0, 1, 2, and 3 <p>There are eight main storage card sockets on the backplane, but a maximum of four main storage cards can be placed in the system.</p> <p>The Model 870 main storage cards are installed according to the following rules:</p> <ul style="list-style-type: none"> ▶ Main storage cards are installed in pairs of equal capacity. ▶ Pairs of main storage cards must plug into memory card slots under the same MCM (slots 0 and 1, slots 2 and 3). ▶ Mixed main storage cards must be of the adjacent capacity (4 GB with 8 GB is allowed, 4 GB with 16 GB is not allowed). ▶ Cannot mix main storage cards of more than two capacities (4 GB with 8 GB is allowed, 4 GB with both 8 GB and 16 GB is not allowed). ▶ Mixed main storage cards can be in any order.

Model 890 Main Memory Rules	<p>Memory features for the Model 890:</p> <p>The following memory features are available on the Model 890:</p> <ul style="list-style-type: none"> ▶ #3020 - 4096 MB Main Storage Card (inside): Plugs into memory card slots 0, 1, 2 and 3 ▶ #3021 - 4096 MB Main Storage Card (outside): Plugs into memory card slots 4, 5, 6 and 7 ▶ #3015 - 8192 MB Main Storage Card (inside): Plugs into memory card slots 0, 1, 2 and 3 ▶ #3016 - 8192 MB Main Storage Card (outside): Plugs into memory card slots 4, 5, 6 and 7 ▶ #3035 - 16384 MB Main Storage Card (inside): Plugs into memory card slots 0, 1, 2 and 3 ▶ #3036 - 16384 MB Main Storage Card (outside): Plugs into memory card slots 4, 5, 6 and 7 ▶ #3017 - 32768 MB Main Storage Card (inside): Plugs into memory card slots 0, 1, 2 and 3 ▶ #3018 - 32768 MB Main Storage Card (outside): Plugs into memory card slots 4, 5, 6 and 7 <p>The Model 890 main storage cards are installed into the eight memory card slots in the system unit backplane.</p> <p>The Model 890 main storage cards are installed according to the following rules:</p> <ul style="list-style-type: none"> ▶ Main storage cards are installed in pairs of equal capacity. ▶ The pairs of main storage cards must plug into memory card slots under the same MCM (slots 0 and 1, slots 2 and 3, slots 4 and 5, slots 6 and 7). ▶ Mixed main storage cards must be of the adjacent capacity (4 GB with 8 GB is allowed, 4 GB with 16 GB is not allowed). ▶ Cannot mix main storage cards of more than two capacities (4 GB with 8 GB is allowed, 4 GB with 8 GB and 16 GB is not allowed). ▶ Mixed main storage cards can be in any order. <p>Important: Fill all slots. An exception is allowed for 16 GB on a 24-way processor and for 24 GB on a 32-way processor.</p>
#3015	<p>8192 MB Main Storage Card (PSIMM)</p> <p>The #3015 is used in the Models 870 and 890. The #3015 can be placed in an “inside” main storage card slot only (slots 0, 1, 2, and 3). See “Model 870 Main Memory Rules” on page 165 or “Model 890 Main Memory Rules” on page 166 for memory restrictions. The #3015 is withdrawn from marketing as of 01 June 2006.</p>
#3016	<p>8192 MB Main Storage Card (PSIMM)</p> <p>The #3016 is used in the Model 890. The #3016 can be placed in an “outside” main storage card slot only (slots 4, 5, 6, and 7). See “Model 890 Main Memory Rules” on page 166 for memory restrictions. The #3016 is withdrawn from marketing as of 01 June 2006.</p>
#3017	<p>32768 MB Main Storage Card (PSIMM)</p> <p>The #3017 is used in the Models 870 and 890. The #3017 can be placed in an “inside” main storage card slot only (slots 0, 1, 2, and 3). See “Model 870 Main Memory Rules” on page 165 or “Model 890 Main Memory Rules” on page 166 for memory restrictions. The #3017 is withdrawn from marketing as of 01 June 2006.</p>
#3018	<p>32768 MB Main Storage Card (PSIMM)</p> <p>The #3018 is used in the Model 890. The #3018 can be placed in an “outside” main storage card slot only (slots 4, 5, 6, and 7). The #3018 is withdrawn from marketing as of 01 June 2006.</p>
#3020	<p>4096 MB Main Storage Card (PSIMM)</p> <p>The #3020 is used in the Models 870 and 890. The #3020 can be placed in an “inside” main storage card slot only (slots 0, 1, 2, and 3). See “Model 870 Main Memory Rules” on page 165 or “Model 890 Main Memory Rules” on page 166 for memory restrictions. The #3020 is withdrawn from marketing as of 01 June 2006.</p>
#3021	<p>4096 MB Main Storage Card (PSIMM)</p> <p>The #3021 is used in the Model 890. The #3021 can be placed in an “outside” main storage card slot only (slots 4, 5, 6, and 7). See “Model 890 Main Memory Rules” on page 166 for memory restrictions. The #3021 is withdrawn from marketing as of 01 June 2006.</p>

#3022	<p>128 MB Main Storage (DIMM 64 Mb technology) The #3022 is available as a support only feature on the Model 810. It can only be ordered up to the minimum number of DIMMs are required to meet a pair or quad system memory requirement. See “Model 810 Main Memory Rules” on page 164 for memory restrictions.</p> <p>Minimum operating system level: OS/400 V5R2 Supported on the Model 810 #2469 processor The #3022 is a Customer Install Feature. The #3022 is withdrawn from marketing as of 01 June 2006.</p>
#3024	<p>256 MB Main Storage (DIMM 128 Mb technology, unstacked) See “Model 810 Main Memory Rules” on page 164 for memory restrictions.</p> <p>Minimum operating system level: OS/400 V5R2 Supported on the Model 810 #2469 processor. The #3024 is a Customer Install Feature. The #3024 is withdrawn from marketing as of 01 June 2006.</p>
#3025	<p>512 MB Main Storage (DIMM 128 Mb technology, stacked) The #3025 cannot be mixed with the #3026 in pairs or quads. See “Model 810 Main Memory Rules” on page 164 for memory restrictions.</p> <p>Minimum operating system level: OS/400 V5R2 Supported on the Model 810 #2469 processor. The #3025 is a Customer Install Feature.</p>
#3026	<p>512 MB Main Storage (DIMM 256 Mb technology, unstacked) The #3026 cannot be mixed with the #3025 in pairs or quads. See “Model 810 Main Memory Rules” on page 164 for memory restrictions.</p> <p>Minimum operating system level: OS/400 V5R2 Supported on the Model 810 #2469 processor. The #3026 is a Customer Install Feature. The #3026 is withdrawn from marketing as of 01 June 2006.</p>
#3027	<p>1 GB Main Storage (DIMM 256 Mb technology, stacked) See “Model 810 Main Memory Rules” on page 164 for memory restrictions.</p> <p>Minimum operating system level: OS/400 V5R2 Supported on the Model 810 #2469 processor. The #3027 is a Customer Install Feature. The #3027 is withdrawn from marketing as of 01 June 2006.</p>
#3029	<p>128 MB Main Storage (DIMM 128 Mb technology, unstacked) The #3022 cannot be mixed with the #3029 in pairs or quads. See “Model 810 Main Memory Rules” on page 164 for memory restrictions.</p> <p>Minimum operating system level: OS/400 V5R2 Supported on the Model 810 #2469 processor. The #3029 is a Customer Install Feature.</p>
#3035	<p>16384 MB Main Storage Card (PSIMM) The #3035 is used in the Models 870 and 890. The #3035 can be placed in an “inside” main storage card slot only (slots 0, 1, 2, and 3). See “Model 870 Main Memory Rules” on page 165 and “Model 890 Main Memory Rules” on page 166 for memory restrictions. The #3035 is withdrawn from marketing as of 01 June 2006.</p>
#3036	<p>16384 MB Main Storage Card (PSIMM) The #3036 is used in the Model 890. The #3036 can be placed in an “outside” main storage card slot only (slots 4, 5, 6, and 7). See “Model 890 Main Memory Rules” on page 166 for memory restrictions. The #3036 is withdrawn from marketing as of 01 June 2006.</p>

#3042	<p>256 MB Main Storage (DIMM - DDR - 128 Mb technology, unstacked) Refer to "Model 825 Main Memory Rules" on page 165 for memory restrictions.</p> <p>Minimum operating system level: OS/400 V5R2 Supported on Model 825 processors. The #3042 is a Customer Install Feature. The #3042 is withdrawn from marketing as of 01 June 2006.</p>
#3043	<p>512 MB Main Storage (DIMM - DDR - 256 Mb technology, unstacked) Refer to "Model 570 Main Memory Rules" on page 162 and "Model 825 Main Memory Rules" on page 165 for memory restrictions.</p> <p>Minimum operating system level: OS/400 V5R2 Supported on the Model 570 and 825 processors. The #3043 is a Customer Install Feature. The #3043 is withdrawn from marketing as of 01 June 2006.</p>
#3044	<p>1024 MB Main Storage (DIMM - DDR - 256 Mb technology, stacked) Refer to "Model 570 Main Memory Rules" on page 162 and "Model 825 Main Memory Rules" on page 165 for memory restrictions.</p> <p>Minimum operating system level: OS/400 V5R2 Supported on the Model 570 and Model 825 #2486 processors. The #3044 is a Customer Install Feature. The #3044 is withdrawn from marketing as of 01 June 2006.</p>
#3046	<p>2048 MB Main Storage (DIMM - DDR - 512 Mb technology, stacked) Refer to "Model 570 Main Memory Rules" on page 162 and "Model 825 Main Memory Rules" on page 165 for memory.</p> <p>Minimum operating system level: OS/400 V5R2 Supported on the Model 570 and 825 processors. The #3046 is a Customer Install Feature. The #3046 is withdrawn from marketing as of 01 June 2006.</p>
#3092	<p>256 MB Main Storage DIMM (DDR - 128 Mb technology, unstacked) See "Model 800 Main Memory Rules" on page 164 and "Model 810 Main Memory Rules" on page 164 for memory restrictions.</p> <p>Minimum operating system level: OS/400 V5R2 Supported on the Model 800 #2463 and #2464 processors, and Model 810 #2465, #2466, and #2467 processors The #3092 is a Customer Install Feature. The #3092 is withdrawn from marketing as of 01 June 2006.</p>
#3093	<p>512 MB Main Storage DIMM (DDR - 256 Mb technology, unstacked) See "Model 520 Main Memory Rules" on page 160, "Model 550 Main Memory Rules" on page 160, "Model 800 Main Memory Rules" on page 164, and "Model 810 Main Memory Rules" on page 164 for memory restrictions.</p> <p>Minimum operating system level: OS/400 V5R2 Supported on the Model 520 #8950, #8951, #8952, #8953, #8954 and #8955 (9406) processors, Model 550 #8958 processor, Model 800 #2463 and #2464 processors, and the Model 810 #2465, #2466, and #2467 processors The #3093 is a Customer Install Feature. The #3093 is withdrawn from marketing as of 01 June 2006.</p>
#3094	<p>1 GB Main Storage DIMM (DDR- 256 Mb technology, stacked) See "Model 520 Main Memory Rules" on page 160, "Model 550 Main Memory Rules" on page 160, "Model 800 Main Memory Rules" on page 164, and "Model 810 Main Memory Rules" on page 164 for memory restrictions.</p> <p>Minimum operating system level: OS/400 V5R2 Supported on the Model 520 #8950, #8951, #8952, #8953, #8954 and #8955 (9406) processors, Model 550 #8958 processor, Model 800 #2463 and #2464 processors, and the Model 810 #2465, #2466, and #2467 processors The #3094 is a Customer Install Feature. The #3094 is withdrawn from marketing as of 01 June 2006.</p>

#3096	<p>2 GB Main Storage DIMM (DDR- 256 Mb technology, stacked) See “Model 520 Main Memory Rules” on page 160, “Model 550 Main Memory Rules” on page 160, “Model 800 Main Memory Rules” on page 164, and <i>IBM eServer i5, iSeries, and AS/400e System Builder, October 2005</i>, SG24-2155-11 for memory restrictions.</p> <p>Minimum operating system level: OS/400 V5R2 Supported on the Model 520 #8950, #8951, #8952, #8953, #8954 and #8955 (9406) processors, Model 550 #8958 processor, and Model 800 #2463 processor, and the Model 820 #2465, #2466, #2467 processors The #3096 is a Customer Install Feature. The #3096 is withdrawn from marketing as of 01 June 2006.</p>
#4400	<p>#4400 1GB DDR2 Main Storage The #4400 - 1 GB DDR2 Main Storage Consists of two 512 MB DDR2 DIMMs for a total of 1 GB of main storage. Two available DIMM slots are required. Minimum operating system level: i5/OS V5R3 with V5R3M5 LIC, AIX 5L for POWER V5.2 for IBM eServer, Red Hat Enterprise Linux AS for POWER Version 3, SUSE Linux Enterprise Server 9 for POWER</p> <p>Supported on Models 520+ and 550+. The #4400 is a Customer Install Feature.</p>
#4443	<p>512 MB DDR Main Storage DDR1 - 256 Mb technology Ships two 256 MB DIMMs for a total of 512 MB. It is orderable on the #8950 processor with a maximum of two of these features per system. See “Model 520 Main Memory Rules” on page 160.</p> <p>Supported on Model 520 processors. The #4443 is a Customer Install Feature.</p>
#4444	<p>1 GB DDR Main Storage DDR1 - 256 Mb technology Ships four 256 MB DIMMs for a total of 1 GB See “Model 520 Main Memory Rules” on page 160 and “Model 550 Main Memory Rules” on page 160.</p> <p>Supported on Model 520 and 550 processors. The #4444 is a Customer Install Feature.</p>
#4445	<p>4 GB DDR Main Storage DDR1 - 128 Mb technology Ships four 1 GB DIMMs for a total of 4 GB See “Model 520 Main Memory Rules” on page 160 and “Model 550 Main Memory Rules” on page 160.</p> <p>Supported on Model 520 and 550 processors. The #4445 is a Customer Install Feature.</p>
#4447	<p>2 GB DDR Main Storage DDR1 - 64 Mb technology Ships four 512 MB DIMMs for a total of 2 GB See “Model 520 Main Memory Rules” on page 160 and “Model 550 Main Memory Rules” on page 160.</p> <p>Supported on Model 520 and 550 processors. The #4447 is a Customer Install Feature.</p>
#4449	<p>8 GB DDR Main Storage DDR1 - 128 Mb technology, stacked Ships four 2 GB DIMMs for a total of 8 GB See “Model 520 Main Memory Rules” on page 160 and “Model 550 Main Memory Rules” on page 160.</p> <p>Supported on Model 520 and 550 processors The #4449 is a Customer Install Feature. The #4449 is withdrawn from marketing as of 01 June 2006. A #4450 16 GB DDR-1 Main Storage is the recommended replacement.</p>

#4450	<p>16 GB DDR Main Storage DDR1 - 1 GB technology, stacked Ships four 4 GB DIMMs for a total of 16 GB See “Model 520 Main Memory Rules” on page 160 and “Model 550 Main Memory Rules” on page 160.</p> <p>Supported on Model 520 and 550 processors. The #4450 is a Customer Install Feature.</p>
#4452	<p>2 GB DDR Main Storage DDR1 memory Ships four 512 MB DIMMs for a total of 2 GB See “Model 570 Main Memory Rules” on page 162.</p> <p>Supported on Models 570. The #4452 is a Customer Install Feature.</p>
#4454	<p>8 GB DDR1 Main Storage DDR1 memory, stacked Ships four 2 GB DIMMs for a total of 8 GB See “Model 570 Main Memory Rules” on page 162.</p> <p>Supported on Models 570. The #4454 is a Customer Install Feature.</p>
#4474	<p>#4474 2GB DDR2 Main Storage The #4474 - 2 GB DDR2 Main Storage consists of two 1 GB DDR2 DIMMs for a total of 2 GB of main storage. Two available DIMM slots are required. See “Model 520+ Main Memory Rules” on page 159 and “Model 550+ Main Memory Rules” on page 160 for memory restrictions.</p> <p>Minimum operating system level: i5/OS V5R3 with V5R3M5 LIC, AIX 5L for POWER V5.2 for IBM eServer, Red Hat Enterprise Linux AS for POWER Version 3, SUSE Linux Enterprise Server 9 for POWER Supported on Models 520+ and 550+. The #4474 is a Customer Install Feature.</p>
#4475	<p>#4475 4GB DDR2 Main Storage The #4475 - 4 GB DDR2 Main Storage consists of two 2 GB DDR2 DIMMs for a total of 4 GB of main storage. Two available DIMM slots are required. Minimum operating system level: i5/OS V5R3 with V5R3M5 LIC, AIX 5L for POWER V5.2 for IBM eServer, Red Hat Enterprise Linux AS for POWER Version 3, SUSE Linux Enterprise Server 9 for POWER</p> <p>Supported on Models 520+ and 550+. The #4475 is a Customer Install Feature.</p>
#4477	<p>#4477 8GB DDR2 Main Storage The #4477 - 8 GB DDR2 Main Storage consists of two 4 GB DDR2 DIMMs for a total of 8 GB of main storage. Two available DIMM slots are required. See “Model 520+ Main Memory Rules” on page 159 and “Model 550+ Main Memory Rules” on page 160 for memory restrictions.</p> <p>Minimum operating system level: i5/OS V5R3 with V5R3M5 LIC, AIX 5L for POWER V5.2 for IBM eServer, Red Hat Enterprise Linux AS for POWER Version 3, SUSE Linux Enterprise Server 9 for POWER Supported on Models 520+ and 550+. The #4477 is a Customer Install Feature.</p>
#4490	<p>4 GB DDR1 Main Storage Ships four 1 GB DIMMs for a total of 4 GB See “Model 570 Main Memory Rules” on page 162 for memory restrictions.</p> <p>Supported on Model 570. The #4490 is a Customer Install Feature.</p>
#4491	<p>16 GB DDR1 Main Storage Ships four 4 GB DIMMs for a total of 16 GB See “Model 570 Main Memory Rules” on page 162 for memory restrictions.</p> <p>Supported on Model 570. The #4491 is a Customer Install Feature.</p>

#4492	<p>32 GB DDR1 Main Storage</p> <p>The #4492 32 GB DDR-1 Main Storage feature consists of four 8 GB DIMMs for a total of 32 GB of main storage. The #4492 must be installed on a processor card either by itself (other four DIMM slots empty), with another #2292, with feature #4494, or #7409.</p> <p>See “Model 570 Main Memory Rules” on page 162 for memory restrictions.</p> <p>Supported on Model 570. The #4492 is a Customer Install Feature.</p>
#4494	<p>#4494 - 16 GB DDR-1 Main Storage</p> <p>The #4494 16 GB DDR1 Main Storage consists of four 4 GB DDR1 DIMMs for a total of 16 GB of main storage. The #4494 must be installed on a processor card either by itself (other four DIMM slots empty), with another #4494, or with features #4492 or #7049.</p> <p>Four available memory DIMM slots are required.</p> <p>See “Model 570 Main Memory Rules” on page 162 for memory restrictions.</p> <p>Minimum operating system level: i5/OS V5R3 Supported on Model 570. The #4494 is not a Customer Install Feature.</p>
#4495	<p>#4495 4/8GB DDR2 Main Storage</p> <p>The #4495 - 4/8 GB DDR2 Main Storage provides 4 GB of activated DDR2 memory and an additional 4 GB of DDR2 memory available for activation with four 2 GB DIMMs. The 4 GB of additional memory can be activated in increments of 1 GB. If a memory feature is moved to a different system, that system recognizes only 4 GB as available unless additional memory activations are acquired or already present on that server. For the original system, four 1 GB memory activations remain and can be used for other CUoD memory features. For special situations, contact IBM CoD administration about transferring memory activations between systems.</p> <p>Four available memory DIMM slots are required.</p> <p>See “Model 570+ Main Memory Rules” on page 161 for memory restrictions.</p> <p>Minimum operating system level: i5/OS V5R3 Supported on Model 570+ CUoD systems. The #4495 is not a Customer Install Feature.</p>
#4496	<p>#4496 8/16GB DDR2 Main Storage</p> <p>The #4496 - 8/16 GB DDR2 Main Storage provides 8 GB of activated DDR2 memory and an additional 8 GB of DDR2 memory available for activation with four 4 GB DIMMs. The 8 GB of additional memory can be activated in increments of 1 GB. If a memory feature is moved to a different server, that server recognizes only 8 GB as available unless additional memory activations are acquired or already present on that server. For the original server, eight 1 GB memory activations remain and can be used for other CUoD memory features. For special situations, contact IBM CoD administration about transferring memory activations between servers.</p> <p>Four available memory DIMM slots are required.</p> <p>See “Model 570+ Main Memory Rules” on page 161 for memory restrictions.</p> <p>Minimum operating system level: i5/OS V5R3 Supported on Model 570+ CUoD systems. The #4496 is not a Customer Install Feature.</p>
#4497	<p>#4497 16GB DDR2 Main Storage</p> <p>The #4497 - 16 GB DDR2 Main Storage provides 16 GB of DDR2 system memory with four 4 GB DDR2 DIMMs. Four available memory DIMM slots are required.</p> <p>See “Model 570+ Main Memory Rules” on page 161 for memory restrictions.</p> <p>Minimum operating system level: i5/OS V5R3 Supported on Model 570+. The #4497 is not a Customer Install Feature.</p>
4498	<p>#4498 32GB DDR2 Main Storage</p> <p>The #4498 - 32 GB DDR2 Main Storage provides 32 GB of DDR2 system memory with four 8 GB DDR2 DIMMs. #4498 is comprised of 400 MHz DDR2 DIMMs and cannot be mixed with other Model 570 memory on the same processor card. #4498 can be mixed with other DDR2 memory in the same enclosure or in the same system.</p> <p>Four available memory DIMM slots are required.</p> <p>See “Model 570+ Main Memory Rules” on page 161 for memory restrictions.</p> <p>Minimum operating system level: i5/OS V5R3 Supported on Model 570+. The #4498 is not a Customer Install Feature.</p>

#7049	<p>#7049 - 8/16 GB DDR1 Main Storage</p> <p>The #7049 - 8/16 GB DDR-1 Main Storage provides 8 GB of activated memory and an additional 8 GB of memory available for activation. The 8 GB of additional memory can be activated in increments of 1 GB. #7049 must be installed on a processor card either by itself or with another #7049 or with features #4492 or #4494. See "Model 570 Main Memory Rules" on page 162 for memory restrictions.</p>
#7816	<p>#7816 2/4 GB CUoD Main Storage</p> <p>#7816 is a DDR1, 512 Mb, 266 MHz, DRAM DIMMS DDR1 memory card, which provides 2 GB of activated system memory and an additional 2 GB of system memory available for activation. The 2 GB of additional system memory can be activated in increments of 1 GB. One #3757 Processor Book Service Shelf is required at the customer site for this upgrade. See "Model 595 Main Memory Rules" on page 163 for memory restrictions. Initial order or MES</p> <p>Minimum operating system level: i5/OS V5R3, SUSE Linux Enterprise Server 9 for POWER or Red Hat Enterprise Linux AS for POWER Version 3, AIX 5L for POWER V5.2 Supported on Model 595. The #7816 is an IBM Customer Service Representative setup feature. See "Model 595 Main Memory Rules" on page 163.</p>
#7828	<p>#7828 16 GB Main Storage</p> <p>The #7828 is a DDR1 memory card which provides 16 GB of activated system memory with four 4 GB DIMMS on a card. Initial order or MES. One #3757 Processor Book Service Shelf is required at the customer site if this is an upgrade. See "Model 595 Main Memory Rules" on page 163 for memory restrictions.</p> <p>Minimum operating system level: i5/OS V5R3, SUSE Linux Enterprise Server 9 for POWER or Red Hat Enterprise Linux AS for POWER Version 3, AIX 5L for POWER V5.2 Supported on Model 595. The #7828 is an IBM Customer Service Representative setup feature.</p>
#7829	<p>#7829 32 GB Main Storage</p> <p>The #7829 is a DDR1 memory card which provides 32 GB of activated system memory with four 8 GB DIMMS on a card. One #3757 Processor Book Service Shelf is required at the customer site if this is an upgrade. See "Model 595 Main Memory Rules" on page 163 for memory restrictions. Initial order or MES</p> <p>Minimum operating system level: i5/OS V5R3, SUSE Linux Enterprise Server 9 for POWER or Red Hat Enterprise Linux AS for POWER Version 3, AIX 5L for POWER V5.2 Supported on Model 595. The #7829 is an IBM Customer Service Representative setup feature.</p>
#7835	<p>#7835 4/8 GB CUoD Main Storage</p> <p>The #7835 is a DDR1 memory card which provides 4 GB of activated system memory and an additional 4 GB of system memory available for activation. The 4 GB of additional system memory can be activated in increments of 1 GB. Initial order or MES One #3757 Processor Book Service Shelf is required at the customer site for this upgrade. See "Model 595 Main Memory Rules" on page 163 for memory restrictions.</p> <p>Supported on Model 595. The #7835 is an IBM Customer Service Representative setup feature.</p>
#8195	<p>#8195 - 256 GB Main Storage (32X8)</p> <p>The #8195 provides 32 #7835 4/8 GB fully activated memory features for a total of 256 GB of active DDR1 system memory. Only the #8195 feature is shown on the order or in the install records, not the 32 #7835 features. No #7970 memory activations are required. Requires 32 empty system memory slots on any of processor boards See "Model 595 Main Memory Rules" on page 163 for memory restrictions. Initial order or MES</p> <p>Supported only on Model 595. The #8195 is a Customer Install Feature.</p>

#8197	<p>#8197 512 GB Main Storage (32x16) The #8197 provides 32 #7828 16 GB fully activated memory features for a total of 512 GB of active DDR1 system memory. Only the #8197 feature is shown on the order or in the install records, not the 32 #7828 features. Requires 32 empty system memory slots an any of processor boards See “Model 595 Main Memory Rules” on page 163 for memory restrictions.</p> <p>Supported on Model 595. The #8197 is a Customer Install Feature.</p>
#8198	<p>#8198 - 512 GB Main Storage (16x32) The #8198 provides 16 #7829 32 GB fully activated memory features for a total of 512 GB of active DDR1 system memory. Only the #8198 feature is shown on the order or in the install records, not the 16 #7829 features. Requires 16 empty system memory slots an any of processor boards See “Model 595 Main Memory Rules” on page 163 for memory restrictions. Initial order or MES</p> <p>Supported on Model 595. The #8198 is a Customer Install Feature. The #8198 is withdrawn from marketing as of 31 January 2006.</p>
#9544	<p>#9544 Base 1 GB DDR Main Storage DDR1 - 256 Mb technology Ships four 256 MB DIMMs for a total of 1 GB See “Model 520 Main Memory Rules” on page 160 and “Model 550 Main Memory Rules” on page 160.</p> <p>Supported on Model 520 #7390, #7391, #7393 Express Editions.</p>
#9545	<p>#9545 Base 4 GB DDR Main Storage DDR1 - 128 Mb technology Ships four 1 GB DIMMs for a total of 4 GB See “Model 520 Main Memory Rules” on page 160 and “Model 550 Main Memory Rules” on page 160.</p> <p>Supported on Model 520 #7395 and #7396 Express Editions.</p>
#9547	<p>2 GB DDR Main Storage DDR1 - 64 Mb technology Ships four 512 MB DIMMs for a total of 2 GB See “Model 520 Main Memory Rules” on page 160 and “Model 550 Main Memory Rules” on page 160.</p> <p>Supported on Models 520 #7392, #7394 Express Editions.</p>

4.6 PCI IOP controllers

PCI IOP controllers	
PCI Rules	<p>PCI cards are subject to plugging rules. Refer to 4.1, “PCI card placement for IBM System i5, eServer i5 and iSeries servers” on page 98, for an introduction to PCI. <i>PCI and PCI-X Placement Rules for IBM System i5, eServer i5, and iSeries servers with i5/OS V5R4 and V5R3</i>, REDP-4011 and <i>PCI Card Placement Rules for the IBM @server iSeries Server OS/400 Version 5 Release 2: September 2003</i>, REDP-3638 for OS/400 V5R2 and earlier releases, describe the configuration and card placement rules that you must understand and follow to develop valid configurations. Use these IBM Redpapers as a guide when configuring IOAs and IOPs so that the system is sized to meet client expectations.</p>
Embedded IOP	<p>Embedded 32 MB Base PCI IOP (CCIN 284C) The embedded IOP is standard on every Model 800, 810, and 820 system tower, and the #5075 PCI Expansion Tower. This IOP is embedded and, therefore, does not require a PCI card slot. The embedded base PCI IOP provides support for a maximum of four IOAs, including the #5702 PCI-X Ultra Tape Controller or #9767 Base PCI Disk Unit Controller SCSI IOA, the #9771, #9773, or #9774 PCI 2-Line WAN with integrated modem and the System Console IOA. See “#2843 PCI IOP” on page 175, for a list of other supported cards.</p>

<p>#9844 Base IOP</p>	<p>#9844 Base PCI IOP</p> <p>The #9844 Base PCI IOP (CCIN 2844) is a PCI I/O processor which drives PCI IOA adapters. It has been included as part of the base system units for Models 520, 570, 825, 870, and 890, and also can be included as part of the base with the following expansion towers or units:</p> <ul style="list-style-type: none"> ▶ #5094 PCI-X Expansion Tower ▶ #0595/#5095 PCI-X Expansion Tower ▶ #5294 1.8m I/O Tower (Quantity of two) ▶ #8094 Optional 1.8 M I/O Rack (Quantity of two) ▶ #9094 Base PCI I/O Enclosure ▶ #9194 Base PCI I/O Enclosure <p>The #9844 Base PCI IOP can be on initial system orders or on MES orders which add #0595/#5095, #5094, #5294, #8094, or #9094 towers to an installed system. As of 31 January 2006 the #9844 is not included in all systems and towers. See the “#9844 Inclusion Rules” on page 174 for configuration considerations.</p> <p>On the #0588/#5088 PCI-X Expansion Unit or Tower, a #9844 Base PCI IOP is <i>not</i> included as part of the base unit or tower.</p> <p>See “#2844 PCI IOP” on page 177, for a list of other supported cards.</p> <p>Supported on Models 520, 550, 570, 595, 800, 810, 825, 870, 890, and 9411-100.</p>
<p>#9844 Inclusion Rules</p>	<p>As of 31 January 2006, the #9844 is not always included in system units and expansion towers. The inclusion rules are as follows:</p> <ul style="list-style-type: none"> ▶ For expansions ordered after 31 January 2006, a #9844 or #9943 IOP is not included at no-charge. The order process tools (LVT, manufacturing configurator and marketing configurator) cease to default any IOP for expansion units, but do require priced IOPs (for example, the #2844) as required to support the IOAs that are ordered. The exception to this is the “base” I/O tower (#8294 or #9194) on the Model 595. The marketing configurator defaults to a #9844 on a Model 595 with a 1.65 GHz processor and allows de-selection of the #9844 if i5/OS V5R4 is ordered. ▶ The existing definition of features #5560, #5561, #5562 and #5563 mirror tower packages include an enclosure equivalent to a #0595 or #5095. The #0595 and #5095 have included an IOP to be ordered at no-charge. That IOP is assumed to be part of the #0595 and #5095 in the four mirror tower packages. As of 31 January 2006, #0595 and #5095 ordered as features, on their own, no longer allow a no-charge IOP to be ordered for them. However, because each of the four mirror tower package features also include two disk IOAs (that cannot run IOP-less), the intent is to continue to allow a no-charge IOP (a #9844) to be ordered with each of the four mirroring package features. ▶ Model 520, 550 and 570 systems ordered with processors announced prior to 31 January 2006 (1.5 GHz and 1.65 GHz processors) include one no-charge IOP (a #9844) to be placed in the first IOP slot in the system unit. This is limited to one #9844 per system including a Model 570 with multiple system unit enclosures. ▶ A Model 595 system ordered with processor features (1.65 GHz) announced prior to 31 January 2006 include one no-charge IOP (#9844), regardless of whether i5/OS V5R3 or V5R4 is ordered. When V5R3 is ordered, this #9844 must be placed in the #8294 or #9194. When V5R4 is ordered, the marketing configurator allows the #9844 to be de-selected. If the #9844 is ordered, it can be placed wherever required within the system. ▶ 9406 systems ordered with 31 January 2006 announced processors (1.9 GHz and 2.2 GHz) do not allow any no-charge IOPs (except in conjunction with mirror tower package features), regardless of whether i5/OS V5R3 or V5R4 is ordered. ▶ Models 550, 570 and 595 ordered with 31 January 2006 announce processors (1.9 GHz and 2.2 GHz) and i5/OS V5R3 require an IOP. The required IOP (a #2844) must be purchased. ▶ 9405 Model 520 systems ordered with 31 January 2006 announce processors (1.9 GHz) allow a single no-charge IOP (a #9844 to drive the included twinaxial IOA) to be ordered and placed in the first IOP slot in the system unit. ▶ 9406 systems ordered with i5/OS V5R4 support IOP-less in all expansion towers, including the primary I/O tower on the Model 595 (1.65 GHz and 1.9 GHz processors). A Model 595 ordered with a 1.65 GHz processor and i5/OS V5R4 continues to default a no-charge IOP, even though IOP-less is supported in the primary I/O tower. The marketing configurator defaults to a #9844 on the interface for all Model 595s when a 1.65 GHz processor is selected. The #9844 can be deselected if i5/OS V5R4 is also selected. See page 185 for IOP-less placement considerations. ▶ IOPs on existing systems (both priced and no-charge features) migrate when doing model upgrades. No-charge IOP features are supported but are not orderable, except as explicitly noted otherwise.
<p>#9943 Base IOP</p>	<p>#9943 Base PCI IOP</p> <p>The #9943 Base PCI IOP (CCIN 2843) is included as the base IOP for Model 830 (in the #9074 Base I/O Tower), Model 840 (in either the #9079 Base I/O Tower or the #8079 Optional Base 1.8 M I/O Rack), and Model 890 (in either the #9094 Base PCI I/O Enclosure or #8093 Optional 1.8 M I/O Rack) and in the #5074 PCI Expansion Tower and #5079 1.8 M I/O Tower.</p> <p>The #5079, #8079, and #8093/#5097 include two base IOPs.</p> <p>See “#2843 PCI IOP” on page 175, for a list of other supported cards.</p>

<p>#2843 #9943</p>	<p>#2843 PCI IOP</p> <p>The #2843/#9943 is a PCI I/O processor with 64 MB of memory that drives up to four PCI IOA adapters on the Models 810, 820, 825, 830, 840, 870, 890, #5074 PCI Expansion Tower, #5075 PCI Expansion Tower when attached to the Model 820, and on the #0578/#5078 PCI Expansion Unit, #0588/#5088 PCI-X Expansion Unit, #5094 PCI-X Expansion Tower, #0595/#5095 PCI-X Expansion Tower, #5294 1.8m I/O Tower, and the #5079 1.8 M I/O Tower.</p> <p>The following IOAs are supported (driven) by the embedded PCI IOP on the Model 820 and the #2843/#9943 PCI IOP:</p> <ul style="list-style-type: none"> ▶ #2742 Two-Line WAN IOA ▶ #2743 1 Gbps PCI Ethernet IOA ▶ #2744 PCI 100 Mbps Token Ring IOA ▶ #2749 PCI Ultra Magnetic Media Controller ▶ #2757 PCI-X Ultra RAID Disk Controller ▶ #2760 PCI 1 Gbps Ethernet UTP Adapter ▶ #2763 PCI RAID Disk Unit Controller ▶ #2765 PCI Fibre Channel Tape Controller ▶ #2766 PCI Fibre Channel Disk Controller ▶ #2768 PCI Magnetic Media Controller ▶ #2772 PCI Dual WAN/Modem IOA ▶ #2773 PCI Dual WAN/Modem IOA ▶ #2780 PCI-X Ultra4 RAID Disk Controller ▶ #2787 PCI-X Fibre Channel Disk Controller ▶ #2793 Two-Line WAN IOA with Modem ▶ #2794 Two-Line WAN IOA with Modem ▶ #2805 PCI Quad Modem IOA ▶ #2806 PCI Quad Modem (CIM) ▶ #2817 PCI 155 Mbps MMF ATM IOA ▶ #2849 10/100 Mbps Ethernet Adapter ▶ #4723 PCI 10 Mbps Ethernet Adapter ▶ #4745 PCI 2-line WAN IOA ▶ #4746 PCI Twinaxial IOA ▶ #4748 PCI RAID Disk Unit Controller ▶ #4750 PCI ISDN BRI U IOA ▶ #4751 PCI ISDN BRI S/T IOA ▶ #4761 PCI Integrated Analog Modem ▶ #4778 PCI RAID Disk Unit Controller ▶ #4801 PCI Cryptographic Coprocessor ▶ #4805 PCI Cryptographic Accelerator ▶ #4815 PCI ATM 155 Mbps UTP OC3 ▶ #4816 PCI ATM 155 Mbps MMF ▶ #4818 PCI ATM 155 Mbps SMF OC3 ▶ #4838 PCI 100/10 Mbps Ethernet IOA ▶ #5700 PCI 1 Gbps Ethernet IOA ▶ #5701 PCI 1 Gbps Ethernet UTP IOA ▶ #5702 PCI-X Ultra Tape Controller ▶ #5703 PCI-X RAID Disk Unit Controller ▶ #5704 PCI-X Fibre Channel Tape Controller ▶ #5705 PCI-X Tape/DASD Controller ▶ #5712 PCI-X Tape/DASD Controller ▶ #5715 PCI-X Tape/DASD Controller ▶ #9767 Base PCI Disk Unit Controller ▶ #9771 Base PCI 2-Line WAN with integrated modem ▶ #9778 Base PCI RAID Disk Unit Controller ▶ #9793 2-Line WAN IOA with Modem ▶ #9794 2-Line IOA with Modem <p>Up to five #2843 PCI IOPs can be added to the Model 820 system unit. When attached to a Model 820, the #5075 can contain or support up to three #2843 PCI IOP features.</p> <p>On the #5074 PCI Expansion Tower, a PCI IOP is not embedded, but a #9943 Base PCI IOP is included. Up to five #2843 PCI IOPs can be added to a #5074. Up to six #2843 PCI IOPs can be added to a #5078.</p> <p>On the #5079 1.8 M I/O Tower, a PCI IOP is not embedded, but two #9943 Base PCI IOP are included. Up to 10 #2843 PCI IOPs can be added to the #5079.</p>
------------------------	---

#2843 #9943 (cont.)	<p>#2843 PCI IOP</p> <p>The #9943 can only be on initial system orders or on MES orders that add #5074, #5078, or #5079 towers to an installed system. The maximum number of #9943s installed on a system is one in the system unit, plus one in each #5074 and two in each #5079. Refer to <i>PCI and PCI-X Placement Rules for IBM System i5, eServer i5, and iSeries servers with i5/OS V5R4 and V5R3</i>, REDP-4011, or <i>PCI Card Placement Rules for the IBM @server iSeries Server OS/400 Version 5 Release 2: September 2003</i>, REDP-3638 for OS/400 V5R2 and earlier releases, for further restrictions.</p> <p>The #281x ATM, #2750, #2751, and #2761 are not supported with i5/OS V5R3. The #2843 is a Customer Install Feature. The #2843 is withdrawn from marketing as of 01 October 2004. A #2844 is the recommended replacement.</p>
---------------------------	--

#2844 #9844	<p>#2844 PCI IOP</p> <p>The #2844 PCI IOP is a PCI I/O processor which drives PCI IOA adapters in the Model 270, 520, 550, 570, 595, 800, 810, 820, 825, 830, 840, 870, and 890 system units and the following expansion towers and units:</p> <ul style="list-style-type: none"> ▶ #0578 PCI Expansion Unit in Rack ▶ #0588 PCI-X Expansion Unit in Rack ▶ #0595 PCI-X Expansion Unit in Rack ▶ #5074 PCI Expansion Tower ▶ #5075 PCI Expansion Tower ▶ #5078 PCI Expansion Unit ▶ #5079 1.8 M I/O Tower ▶ #5088 PCI-X Expansion Unit ▶ #5094 PCI-X Expansion Tower ▶ #5095 PCI-X Expansion Tower ▶ #5294 1.8m I/O Tower ▶ #5790 PCI Expansion Drawer ▶ #8079 Optional Base 1.8 M I/O Rack ▶ #8093 Optional 1.8 M I/O Rack ▶ #8094 Optional 1.8 M I/O Rack ▶ #8294 Optional Base 1.8 M Rack ▶ #9079 Base I/O Tower (PCI) ▶ #9094 Base PCI I/O Enclosure ▶ #9194 Base PCI-X Expansion Tower <p>The #9844 Base PCI IOP is included with Models 520, 550, 570, 595, 825, 870, and 890, and PCI-X I/O towers #0595, #5094, #5095, #5294, #8094, and #9094. Two #9844 PCI IOPs are included as base in the #5294 1.8 M I/O Tower. A #9844 Base PCI IOP is not included in the base of the #0578, #5078, #0588, and #5088.</p> <p>The following IOAs are supported (driven) by the #2844/#9944 PCI IOP:</p> <ul style="list-style-type: none"> ▶ CCIN 288E Embedded 10/100 Mbps Ethernet IOA (Model 825 only) ▶ #2742 2-Line WAN IOA ▶ #2743 1 Gbps PCI Ethernet IOA ▶ #2744 PCI 100 Mbps Token Ring IOA ▶ #2749 PCI Ultra Magnetic Media Controller ▶ #2757 PCI-X Ultra RAID Disk Controller ▶ #2760 PCI 1 Gbps Ethernet UTP Adapter ▶ #2763 PCI RAID Disk Unit Controller ▶ #2765 PCI Fibre Channel Tape Controller ▶ #2766 PCI Fibre Channel Disk Controller ▶ #2768 PCI Magnetic Media Controller ▶ #2772 PCI Dual WAN/Modem IOA ▶ #2773 PCI Dual WAN/Modem IOA ▶ #2780 PCI-X Ultra4 RAID Disk Controller ▶ #2782 PCI-X RAID Disk Unit Controller ▶ #2787 PCI-X Fibre Channel Disk Controller ▶ #2793 2-Line WAN IOA with Modem ▶ #2794 2-Line WAN IOA with Modem ▶ #2805 PCI Quad Modem IOA ▶ #2806 PCI Quad Modem (CIM) ▶ #2817 PCI 155 Mbps MMF ATM IOA ▶ #2849 10/100 Mbps Ethernet Adapter ▶ #4723 PCI 10 Mbps Ethernet Adapter ▶ #4745 PCI 2-line WAN IOA ▶ #4746 PCI Twinaxial IOA ▶ #4750 PCI ISDN BRI U IOA ▶ #4751 PCI ISDN BRI S/T IOA ▶ #4748 PCI RAID Disk Unit Controller ▶ #4761 PCI Integrated Analog Modem ▶ #4778 PCI RAID Disk Unit Controller ▶ #4801 PCI Cryptographic Coprocessor (not supported by embedded IOP) ▶ #4805 PCI Cryptographic Accelerator (not supported by embedded IOP) ▶ #4811 PCI Integrated xSeries Server ▶ #4812 PCI Integrated xSeries Server ▶ #4813 PCI Integrated xSeries Server ▶ #4815 PCI ATM 155 Mbps UTP OC3 ▶ #4816 PCI ATM 155 Mbps MMF ▶ #4818 PCI ATM 155 Mbps SMF OC3
----------------	---

#2844
#9844
(cont.)

#2844 PCI IOP

- ▶ #4838 PCI 100/10 Mbps Ethernet IOA
- ▶ #5700 PCI 1 Gbps Ethernet IOA
- ▶ #5701 PCI 1 Gbps Ethernet UTP IOA
- ▶ #5702 PCI-X Ultra Tape Controller
- ▶ #5703 PCI-X RAID Disk Unit Controller
- ▶ #5704 PCI-X Fibre Channel Tape Controller
- ▶ #5705 PCI-X Tape/DASD Controller
- ▶ #5712 PCI-X Tape/DASD Controller
- ▶ #5715 PCI-X Tape/DASD Controller
- ▶ #9748 Base PCI RAID Disk Unit Controller
- ▶ #9767 Base PCI Disk Unit Controller
- ▶ #9771 Base PCI 2-Line WAN with integrated modem
- ▶ #9778 Base PCI RAID Disk Unit Controller
- ▶ #9793 2-Line WAN IOA with Modem
- ▶ #9794 2-Line IOA with Modem
- ▶ #9812 Base PCI Integrated xSeries Server
- ▶ #9813 PCI Integrated xSeries Server

Placement considerations (maximums) for the #2844 include:

- ▶ Up to two in the Model 270, 800, and 810 system units
- ▶ Five in the 820 system tower
- ▶ Up to five in the Model 820 system unit
- ▶ Up to three in the Model 825 system unit
- ▶ Four in the base I/O tower of the Model 830 and 840
- ▶ Up to four in the Model 830, 840, 870, and 890 system units
- ▶ Three in a #5075 PCI Expansion Tower
- ▶ Two in an #0595/#5095 PCI-X Expansion Tower
- ▶ Two can be added to the base #9844 PCI IOP in the #0595/#5095 PCI-X Expansion Tower
- ▶ Five in a #5074 PCI Expansion Tower and #5094 PCI-X Expansion Tower
- ▶ Up to five can be added to the base #9844 PCI IOP in a #5074/#5094
- ▶ Six in an #0578, #0588, #5078, or #5088 PCI-X Expansion Unit
- ▶ Up to six can be added in the #0578/#5078 and #0588/#5088
- ▶ 10 in a #5079 1.8 M I/O Tower and #5294 1.8m I/O Tower
- ▶ Up to 10 can be added to a #5079/#5294
- ▶ The #5790 PCI Expansion Drawer supports two #2844s with blindswap cards. Two #5790s can be placed side by side in a rack with #7311 Dual I/O Unit Enclosure

The #2844 supports a maximum of 16 devices.

Minimum operating system level: OS/400 V5R2

The #281x ATM, #2750, #2751, #2761, and #4761 are not supported with i5/OS V5R3.

The #2844 is a Customer Install Feature.

<p>#2847</p>	<p>#2847 PCI IOP for SAN Load Source</p> <p>The #2847 PCI IOP for SAN Load Source provides the specialized function required to locate the load source disk on an external disk server attached via a fibre channel adapter, and boot from that load source. The #2847 PCI IOP for SAN Load Source does not support multipath for the i5/OS load source disk unit, but does support multipath for all other logical units (LUNs) attached to this IOP. A minimum of two IOPs are required to enable redundancy. Refer to <i>iSeries and IBM TotalStorage: A Guide to Implementing External Disk on eServer i5</i>, SG24-7120, for more information.</p> <p>The #2847 PCI IOP for SAN Load Source supports a maximum of one IOA of either:</p> <ul style="list-style-type: none"> ▶ #2766 PCI Fibre Channel Disk Controller ▶ #2787 PCI-X Fibre Channel Disk Controller <p>Supported on the Model 520, 550, 570, 595 system units, and on the following expansion towers and units:</p> <ul style="list-style-type: none"> ▶ #0588 PCI-X Expansion Unit in Rack ▶ #0595 PCI-X Expansion Unit in Rack ▶ #5074 PCI Expansion Tower ▶ #5079 1.8 M I/O Tower ▶ #5088 PCI-X Expansion Unit ▶ #5094 PCI-X Expansion Tower ▶ #5095 PCI-X Expansion Tower ▶ #5294 1.8m I/O Tower ▶ #5790 PCI Expansion Drawer ▶ #8079 Optional Base 1.8 M I/O Rack ▶ #8093 Optional 1.8 M I/O Rack ▶ #8094 Optional 1.8 M I/O Rack ▶ #9079 Base I/O Tower (PCI) ▶ #9094 Base PCI I/O Enclosure ▶ #9194 Base PCI-x Expansion Tower ▶ #8294 Optional Base 1.8m rack <p>Minimum operating system level: i5/OS V5R3 with #0531 i5/OS V5R3, V5R3M5 LIC</p>
<p>#2790 #2791 #2799</p>	<p>#2790 PCI Integrated Netfinity Server, #2791 PCI Integrated xSeries Server and #2799 PCI Integrated xSeries Server</p> <p>The #2790 PCI Integrated Netfinity Server contains a 700 MHz processor. The #2791 PCI Integrated xSeries Server contains an 850 MHz processor. The #2799 PCI Integrated xSeries Server contains a 1.0 GHz Intel® Pentium® III processor. Each processor contains four memory slots in the xSeries IOP.</p> <p>The #2790, #2791, or #2799 is supported in the system unit of the Models 820, 825, 830, 840, 870, and 890, and #5074 PCI Expansion Tower, #5075 PCI Expansion Tower, #5078 PCI Expansion Unit, #0588/#5088 PCI-X Expansion Unit, and #5079 1.8 M I/O Towers.</p> <p>Each main storage slot of the #2790, #2791, or #2799 server can contain either a 128 MB, 256 MB, or 1024 MB xSeries server main storage card, providing a total server main storage capacity ranging from 128 MB to 4096 MB (4 GB). A minimum of one main storage card is required on the xSeries IOP. A maximum of 3712 MB of memory is addressable.</p> <p>Allowable main storage increments in MB are 128, 256, 384, 512, 640, 768, 896, 1024, 1152, 1280, 1408, 1536, 1664, 1792, 2048, 2176, 2304, 2432, 2560, 3072, 3200, 3328, and 4096.</p> <p>The following main storage cards provide server memory for the #2790, #2791, or #2799 when installed in a Model 820, 825, 830, 840, 870, or 890 system unit or attachable HSL towers:</p> <ul style="list-style-type: none"> ▶ #2795 - 128 MB server memory (withdrawn from marketing as of 19 November 2004) ▶ #2796 - 256 MB server memory (withdrawn from marketing as of 19 November 2004) ▶ #2797 - 1 GB server memory (withdrawn from marketing as of 01 June 2006) ▶ #2895 - 128 MB server memory (withdrawn from marketing as of 19 November 2004 for new orders only. Conversions to feature remain.) ▶ #2896 - 256 MB server memory (withdrawn from marketing as of 19 November 2004 for new orders only. Conversions to feature remain.) <p>The #2790, #2791, and #2799 can support PCI 100/16/4 Mbps Token Ring IOAs, PCI 100/10 Mbps Ethernet IOAs, or PCI 1 Gbps Ethernet IOAs in any combination. At least one LAN IOA is required. The supported LAN IOA features are:</p> <ul style="list-style-type: none"> ▶ #2743 1 Gbps PCI Ethernet IOA ▶ #2744 PCI 100 Mbps Token Ring IOA ▶ #2760 PCI 1 Gbps Ethernet UTP Adapter ▶ #4838 PCI 100/10 Mbps Ethernet IOA

#2790 #2791 #2799 (cont.)	<p>#2790 PCI Integrated Netfinity Server, #2791 PCI Integrated xSeries Server and #2799 PCI Integrated xSeries Server</p> <p>A #0223 100 Mbps Token-Ring specify code is required on the Integrated xSeries Server for each #2744 selected to run on the #2790, #2791, or #2799.</p> <p>A #0224 100/10 Mbps Ethernet specify code is required on the Integrated xSeries Server for each #4838 selected to run on the #2790, #2791, or #2799.</p> <p>A #0225 1 Gbps Ethernet specify code is required on the Integrated xSeries Server for each #2743/#2760 selected to run on the #2790, #2791, or #2799.</p> <p>Up to three IOA LAN features are supported by the #2790, #2791, or #2799, depending on which system or expansion tower position the #2790, #2791, or #2799 is placed. The #2790, #2791, and #2799 require three PCI card slots on the Model 820, 830, or 840 system unit backplane. One slot is consumed. The second slot is unusable. The third slot is reduced to a short card slot which is then used by the first attached LAN IOA card.</p> <p>The #2790, #2791, and #2799 do not require a #2843 or #9943. However, placement is limited to specific slots within the specific system tower and expansion tower.</p> <p>The #2790, #2791, and #2799 support only the Windows® NT, Windows 2000 and Windows Server® 2003 operating systems. The Windows 2003 Server operating system is supported at OS/400 V5R2 with PTFs and i5/OS V5R3.</p> <p>The following rules apply:</p> <ul style="list-style-type: none"> ▶ #0325 IPCS Extension Cable for Windows is the default but can be removed. ▶ #1700 IPCS Keyboard or Mouse for Windows is the default in those countries or regions offering it. ▶ A display must be connected to the #2790 PCI Integrated Netfinity Server to support Windows. ▶ Windows NT® is not supported with i5/OS V5R3. Upgrade to Windows 2000. <p>For a non-U.S. keyboard, mouse and display, see: http://www.ibm.com/eserver/iserries/integratedxseries/</p> <p>Restrictions:</p> <ul style="list-style-type: none"> ▶ Native OS/400 functions are not supported. ▶ The #2790, #2791, and #2799 do not support an external host LAN. ▶ The #2849 is not supported on any Integrated Netfinity Server/Integrated xSeries Server. <p>Refer to <i>PCI Card Placement Rules for the IBM eServer iSeries Server OS/400 Version 5 Release 2: September 2003</i>, REDP-3638, for complete rules for placing these PCI cards in OS/400 V5R2 and earlier configurations.</p> <p>Windows NT is not supported with i5/OS V5R3. Upgrade to Windows 2000.</p> <p>Minimum operating system level to support #2743 or #2760 on the #2790, #2791, or #2799: OS/400 V5R1</p> <p>Minimum operating system level to support #2790 or #2791: OS/400 V4R5 with Cumulative Package C1005450</p> <p>Minimum operating system level to support #2799: OS/400 V5R1 with PTFs identified in Information APAR II13105 at: http://www.ibm.com/eserver/iserries/support</p> <p>The #2790, #2791, or #2799 are Customer Install Features or an IBM Customer Service Representative setup features depending upon card placement.</p> <p>The #2799 is withdrawn from marketing as of 21 November 2003.</p>
------------------------------------	---

<p>#2792 #9792</p>	<p>#2792 PCI Integrated xSeries Server</p> <p>The #2792 PCI Integrated xSeries Server contains a 1.6 GHz processor and four memory slots in the xSeries IOP. The #9792 Base PCI Integrated xSeries Server is included with Models 825, 870, and 890 when ordered with the iSeries Enterprise Edition. The #9792 includes two #9726 server memory features (must be ordered as a pair). The #9792 is allowed only on new systems that have sufficient PCI slots for manufacturing to place the feature within the system.</p> <p>Each server memory slot of the #2792 PCI Integrated xSeries Server can contain either a 512 MB server memory card or 1024 MB server memory card. At least two server memory cards are required in the xSeries IOP and must be installed in identical pairs. Allowable main storage increments in MB are 1024, 2048, 3072, and 4096. A minimum of 1 GB xSeries IOP memory is required.</p> <p>The following server memory cards provide memory for the #2792 PCI Integrated xSeries Server:</p> <ul style="list-style-type: none"> ▶ #0426 - 512 MB Server Memory (withdrawn from marketing as of 01 June 2006) ▶ #0427 - 1 GB Server Memory (withdrawn from marketing as of 01 June 2006) ▶ #9726 - Base 512 MB server memory (available only on the #9792 Base PCI Integrated xSeries Server) <p>The #2792 PCI Integrated xSeries Server includes one embedded 100/10 Mbps Ethernet LAN controller. The #2792 PCI Integrated xSeries Server can be ordered without any further LAN cards, but supports up to three LAN IOAs in any combination depending on which slot the #2792 is placed. The features for the LAN IOAs are:</p> <ul style="list-style-type: none"> ▶ #2744 PCI 100 Mbps Token Ring IOA ▶ #5700 PCI 1 Gbps Ethernet IOA ▶ #5701 PCI 1 Gbps Ethernet UTP IOA <p>One #0223 100 Mbps Token-Ring Specify is required for each #2744 selected to run on the #2792. One #0226 1 Gbps Ethernet Specify code is required for each #5700 or #5701 selected to run on the #2792.</p> <p>The #2792 does not require a #2843, #2844, #9943, or #9844 IOP. Placement is limited to specific slots within the system towers and expansion towers. The #2792 requires two PCI slots and does not extend into a third slot. The #2792 ships with a keyboard or mouse splitter cable and can support either a standard or USB 1.1 keyboard or mouse. The #2792 PCI Integrated xSeries Server supports only the Windows 2000 Server and Windows 2003 Server operating systems. Windows 2003 Server operating system is supported with OS/400 V5R2 and required PTFs.</p> <p>The following rules apply:</p> <ul style="list-style-type: none"> ▶ #0325 IPCS Extension Cable for Windows is the default (but can be removed). ▶ #1700 IPCS Keyboard/Mouse for Windows is the default (in those countries or regions offering it). ▶ A display must be connected to the Integrated xSeries Server to support Windows. <p>For a non-U.S. keyboard or mouse and display, see: http://www.ibm.com/eserver/iseries/integratedxseries/</p> <p>Native OS/400 functions are not supported. The #2792 does not support external host LAN. The #2849 10/100 Mbps Ethernet Adapter is not supported on the #2792/#9792 Base PCI Integrated xSeries Server.</p> <p>Minimum operating system level: OS/400 V5R2 Supported in the system unit of Models 820, 825, 830, 840, 870, 890 and in the following towers: #5074 PCI Expansion Tower, #5075 PCI Expansion Tower, #0578/#5078 PCI Expansion Unit, #5079 1.8 M I/O Tower, #0588/#5088 PCI-X Expansion Unit, #5094 PCI-X Expansion Tower, #0595/#5095 PCI-X Expansion Tower, #5294 1.8m I/O Tower, #8093/#8094 Optional 1.8 M I/O Rack.</p> <p>Card placement determines whether #2792 is a Customer Install Feature or an IBM Customer Service Representative setup feature.</p> <p>The #2792 and #9792 are withdrawn from marketing as of 01 January 2004.</p>
------------------------	---

#2890 #2891 #2899	<p>#2890 PCI Integrated Netfinity Server, #2891 PCI Integrated xSeries Server, #2899 PCI Integrated xSeries Server</p> <p>The #2890 PCI Integrated Netfinity Server contains a 700 MHz processor. The #2891 PCI Integrated xSeries Server contains an 850 MHz processor. The #2899 PCI Integrated xSeries Server contains a 1 GHz Pentium III processor. Each processor contains four memory slots in the xSeries IOP.</p> <p>Each main storage slot of the #2890, #2891, or #2899 can contain either a 128 MB, 256 MB, or 1024 MB xSeries server main storage card, providing a total main storage capacity ranging from 128 MB to 4096 MB (4 GB). Allowable main storage increments in MB are: 128, 256, 384, 512, 640, 768, 896, 1024, 1152, 1280, 1408, 1536, 1664, 1792, 2048, 2176, 2304, 2432, 2560, 3072, 3200, 3328, and 4096. A minimum of 128 MB xSeries IOP memory is required. When the maximum memory is installed, only 3712 MB is addressable.</p> <p>The following main storage cards provide server memory for the #2890, #2891, and #2899:</p> <ul style="list-style-type: none"> ▶ #2795 - 128 MB Server Memory (withdrawn from marketing as of 19 November 2004) ▶ #2796 - 256 MB Server Memory (withdrawn from marketing as of 19 November 2004) ▶ #2797 - 1 GB Server Memory (withdrawn from marketing as of 01 June 2006) <p>The #2890, #2891, or #2899 can support PCI 100/16/4 Mbps Token Ring IOAs, PCI 100/10 Mbps Ethernet IOAs, or PCI 1 Gbps Ethernet IOAs in any combination. At least one LAN IOA is required. The following LAN IOA features:</p> <ul style="list-style-type: none"> ▶ #2743 1 Gbps PCI Ethernet IOA ▶ #2744 PCI 100 Mbps Token Ring IOA ▶ #2760 PCI 1 Gbps Ethernet UTP Adapter ▶ #4838 PCI 100/10 Mbps Ethernet IOA <p>A #0223 100 Mbps Token-Ring Specify is required on the #2890/#2891/#2899 PCI Integrated xSeries Server for each #2744 selected to run on the #2890/#2891/#2899.</p> <p>A #0224 100/10 Mbps Ethernet Specify is required on the #2890/#2891/#2899 PCI Integrated xSeries Server for each #4838 selected to run on the #2890/#2891/#2899.</p> <p>A #0225 1 Gbps Ethernet Specify is required on the #2890/#2891/#2899 PCI Integrated xSeries Server for each #2743 or #2760 selected to run on the #2890/#2891/#2899.</p> <p>Up to three IOA LAN features can be supported by the #2890, #2891, or #2899, depending on which system or expansion tower position the #2890, #2891, or #2899 is placed. The #2890, #2891, or #2899 requires three PCI card slots. One slot is consumed. The second slot is unusable. The third slot is reduced to a short card slot, which is then used by the first attached LAN IOA card.</p> <p>The #2890, #2891, or #2899 does not require a #2843 or #9943, but placement is limited to specific slots within the various system towers and expansion towers. The #2890, #2891, or #2899 supports only the Windows NT, Windows 2000, and Windows 2003 operating systems. Ships with a keyboard or mouse splitter cable. The following considerations apply:</p> <ul style="list-style-type: none"> ▶ #0325 IPCS Extension Cable for Windows is the default (but can be removed). ▶ #1700 IPCS Keyboard/Mouse for Windows is the default (in those countries or regions that offer it). ▶ A display must be connected to the Integrated xSeries Server to support Windows. <p>For a non-U.S. keyboard, mouse and display, see: http://www.ibm.com/eserver/iserries/integratedxseries/</p> <p>Restrictions:</p> <ul style="list-style-type: none"> ▶ Native OS/400 functions are not supported. ▶ The #2890, #2891, or #2899 does not support external host LAN. ▶ The #2849 is not supported on any Integrated Netfinity Server/Integrated xSeries Server. ▶ Windows NT is not supported with i5/OS V5R3. Upgrade to Windows 2000. <p>Minimum operating system level to support #2890/#2891: OS/400 V4R5 with Cumulative Package C1005450 Minimum operating system level to support #2899: OS/400 V5R1 with PTFs identified in Information APAR II13105 at: http://www.ibm.com/eserver/iserries/support Minimum operating system level to support #2743 or #2760 on the #2890, #2891, or #2899: OS/400 V5R1</p> <p>The #2890, #2891, or #2899 is supported (for migration only) in the Model 800, Model 810, and the #5074 PCI Expansion Tower, #5075 PCI Expansion Tower, #0578/#5078 PCI Expansion Unit, and #5079 1.8 M I/O Tower, #0595/#5095 PCI-X Expansion Tower, #5094/#5294 Expansion Towers, and #0588/#5088 PCI-X Expansion Unit.</p> <p>The #2890, #2891, and #2899 are Customer Install Features. The #2899 is withdrawn from marketing as of 21 November 2003 for new orders. Conversion to feature #2899 remains available.</p>
-------------------------	--

#2892	<p>#2892 PCI Integrated xSeries Server</p> <p>The #2892 PCI Integrated xSeries Server contains a 1.6 GHz processor and four memory slots in the xSeries IOP. Each server memory slot of the #2892 PCI Integrated xSeries Server can contain either a 512 MB server memory card or a 1024 MB server memory card, providing allowable main storage options of 1024 MB, 2048 MB, 3072 MB, and 4096 MB. All server memory cards must be installed in identical pairs.</p> <p>The following main storage cards provide memory for the #2892 PCI Integrated xSeries Server:</p> <ul style="list-style-type: none"> ▶ #0446 - 512 MB Server Memory ▶ #0447 - 1 GB Server Memory <p>The #2892 PCI Integrated xSeries Server includes one embedded 100/10 Mbps Ethernet LAN controller. The #2892 can be ordered without any further LAN cards. The #2892 supports up to three, in any combination (depending into which system or expansion tower position the #2892 is placed), of the following LAN IOA features:</p> <ul style="list-style-type: none"> ▶ #2744 PCI 100 Mbps Token Ring IOA ▶ #5700 PCI 1 Gbps Ethernet IOA ▶ #5701 PCI 1 Gbps Ethernet UTP IOA <p>One #0223 100 Mbps Token-Ring Specify is required for each #2744 selected to run on the #2892. One #0226 1 Gbps Ethernet Specify is required for each #5700 or #5701 selected to run on the #2892.</p> <p>The #2892 PCI Integrated xSeries Server does not require a #2843, #2844, #9943 or #9944 IOP, but placement is limited to specific slots within the various system towers and expansion towers. The #2892 requires two PCI slots and does not extend into a third slot. The #2892 supports only the Windows 2000 Server and the Windows.NET Server operating systems. The #2892 ships with a standard keyboard/mouse splitter cable, and can support either a standard or USB 1.1 keyboard, mouse, or both.</p> <p>The following rules apply:</p> <ul style="list-style-type: none"> ▶ #0325 (IPCS Extension Cable for Windows) is the default (but can be removed). ▶ #1700 (IPCS Keyboard/Mouse for Windows) is the default (in those countries or regions offering it). ▶ A display must be connected to the #2790 PCI Integrated Netfinity Server to support Windows. <p>For a non-U.S. keyboard, mouse and display, see: http://www.ibm.com/eserver/iseries/integratedxseries/ For the Models 800 and 810, the #2892 is orderable for placement in the #5074, #5094, #0578, #0588, #5078 and #5088 expansion towers or units and in the #5079 and #5294 on the Model 810. Native OS/400 functions are not supported. The #2892 PCI Integrated xSeries Server does not support external host LAN. The #2849 10/100 Mbps Ethernet Adapter is not supported on the #2892.</p> <p>Minimum operating system level: OS/400 V5R2 Supported on the Model 270, 800, and 810 system units, on the #5075 PCI Expansion Tower when it is attached to the Model 270 Supported in the #5075 PCI Expansion Tower and #0595/#5095 PCI-X Expansion Tower when these towers are attached to a Model 800 or 810 Card placement determines whether the #2892 is a Customer Install Feature or an IBM Customer Service Representative setup feature. The #2892 is withdrawn from marketing as of 01 January 2004.</p>
#4710 #4810 #9710	<p>#4710/#4810/#9710 PCI Integrated xSeries Server</p> <p>The #4710, #4810, or #9710 PCI Integrated xSeries Servers have 2 GHz processor and four memory slots. Each server memory slot can contain one of the following features, providing a total main storage capacity from 1024 MB to 4096 MB. The feature numbers of the server memory cards are:</p> <ul style="list-style-type: none"> ▶ #0426/#9726 - 512 MB Server Memory (withdrawn from marketing as of 01 June 2006) ▶ #0427 - 1 GB Server Memory (withdrawn from marketing as of 01 June 2006) <p>A minimum of two server memory cards are required and must be installed in identical capacity pairs. On model upgrades or MES orders, a #4710/#4810 can be ordered without memory features if usable supported memory features already exist on the installed system.</p> <p>The #4710, #4810, or #9710 includes one embedded 100/10 Mbps Ethernet LAN controller. The following LAN IOAs are supported in combination:</p> <ul style="list-style-type: none"> ▶ #2744 PCI 100 Mbps Token Ring IOA ▶ #5700 PCI 1 Gbps Ethernet IOA ▶ #5701 PCI 1 Gbps Ethernet UTP IOA <p>The #4710/#4810 can be ordered without any LAN IOA features.</p>

<p>#4710 #4810 #9710 (cont.)</p>	<p>#4710/#4810/#9710 PCI Integrated xSeries Server</p> <p>When a LAN feature is used in conjunction with a #4710, the following ordering rules apply:</p> <ul style="list-style-type: none"> ▶ One #0223 100 Mbps Token-Ring Specify is required for each #2744 driven. ▶ One #0226 1 Gbps Ethernet Specify is required for each #5700/#5701 driven. ▶ Up to three IOA LAN features can be supported by the #4710/#4810, depending on the system unit or tower position into which the #4710, #4810, or #9710 is placed. ▶ Native OS/400 functions are not supported. <p>The #4710, #4810, or #9710 do not support external host LAN.</p> <p>The #4710, #4810, or #9710 do not require a #2843, #2844, #9943 or #9844. Placement is limited to specific slots within the selected system unit and expansion tower. The #4710, #4810, or #9710 require two PCI card slots, and do not hang over a third slot. The #4710, #4810, or #9710 ship with a standard keyboard and mouse splitter cable and can support either standard or USB 1.1 keyboard, mouse, or both. Windows 2000 Server with PTFs and Windows 2003 Server operating systems are supported.</p> <p>The following apply:</p> <ul style="list-style-type: none"> ▶ #0325 (IPCS Extension Cable for Windows) is the default (but can be removed). ▶ A minimum of 1 GB server memory is required. ▶ #1700 (IPCS keyboard or mouse for Windows) is default (in countries offering it). ▶ A display must be connected to the Integrated Server to support Windows. <p>For a non-US keyboard/mouse and display, see: http://www.ibm.com/eserver/iseriessupport/integratedxseries/</p> <p>Minimum operating system level: OS/400 V5R2 with PTFs identified in Information APAR II13609 at: http://www.ibm.com/eserver/iseriessupport</p> <p>The #4710/#9710 is supported in the Model 520, 550, 570, and 595 and the system unit of Models 820, 825, 830, 840, 870, and 890. It is also supported in the following expansion towers when attached to these models: #0578, #0588, #0595, #5074, #5075, #5078, #5079, #5088, #5094, #5095, and #5294, #8079, #8094, #9079, and #9094.</p> <p>The #4810 is supported in Model 270, 800, and 810 system units. It is also supported in the following towers when attached to the #5075, #0578/#5078, #0588/#5088, and #0595/#5095 Expansion Towers. For Models 800 and 810, if the #4810 is placed in a #5094 or #5294, the client install instructions indicate that an IBM Customer Service Representative must be called for card installation.</p> <p>The #9710 is supported in the Model 520, 550, 570, and 595 and the system unit of Models 825, 870, and 890. It is also supported in the following expansion towers when attached to the #0578, #0588, #0595, #5074, #5075, #5078, #5079, #5088, #5094, #5095, and #5294 Expansion Towers.</p> <p>A #4710 is the recommended replacement for the #2792 PCI Integrated xSeries Server. A #4810 is the recommended replacement for the #2892 PCI Integrated xSeries Server. The #4710, #4810 and #9710 are withdrawn from marketing as of 01 June 2006. A #4812 PCI Integrated xSeries Server is the recommended replacement.</p>
<p>#9726</p>	<p>#9726 Base 512 MB Server Memory</p> <p>The #9726 provides 512 MB DDR server memory for the #9792 Base PCI Integrated xSeries Server. The #9726 Base 512 MB Server Memory is allowed on the following editions, with a maximum of two per edition:</p> <ul style="list-style-type: none"> ▶ #7421 Enterprise Edition ▶ #7424 Enterprise Edition ▶ #7427 Enterprise Edition <p>The #9726 Base 512 MB Server Memory must be ordered in pairs.</p> <p>The #9726 is allowed on new systems or upgrades from non 810, 825, 870, or 890 systems into the 810, 825, 870, or 890 models. If the client does not select the #9726 on the initial order, they are not entitled to receive the feature in the future.</p> <p>Supported on Models 520, 550, 570, 595, 825, 870, 890, and 9411-100.</p>
<p>#9744</p>	<p>#9744 Base PCI IOP</p> <p>The #9744 Base PCI IOP is a base PCI I/O processor that drives PCI IOA adapters in the system unit and in HSL attached PCI or PCI-X I/O expansion towers/units. One #9744 can drive a maximum of four IOAs, subject to configuration restrictions. One #9744 is the default on each order, but can be removed, when a #4811, #4812, #4813, #9812, or #9813 PCI-X Integrated xSeries Server is on the order.</p> <p>Supported on Models 520, 550, 570, 595, 800, 810, 825, 870, 890, and 9411-100.</p>

4.6.1 IOP-less IOAs and placement

An IOA that is said to be “IOP-less” can function in an i5/OS partition without an IOP.

The features in the following table are IOP-less. The “Initial IOP-less release” column indicates the minimum release level that the feature is supported as IOP-less (dual mode).

Placement details for the January 2006 announced IOP-less features include:

- ▶ Are supported with an IOP with i5/OS V5R3.
- ▶ Dual-mode IOAs can be used with or without an IOP. An IOA that is said to be IOP-less can function in an i5/OS partition without an IOP.
- ▶ i5/OS V5R4 is required to run in IOP-less mode except for the 1.9 GHz Model 520.
- ▶ The 1.9 GHz Model 520 supports the use of dual-mode IOAs and controllers running in IOP-less mode in the system unit with i5/OS V5R3 and V5R3M5 LIC. Dual mode IOAs can run in IOP-less mode in attached I/O towers
- ▶ The 1.9 and 2.2 GHz Models 520, 550 and 570 support the use of dual-mode IOAs and controllers running in IOP-less mode in the system unit with OS/400 V4R3. Dual mode cards can also run in IOP-less mode in attached I/O towers.
- ▶ Dual mode IOAs and controllers are not supported running in IOP-less mode in the system unit of the 1.5 and 1.65 GHz Models 520, 550, or 570. Dual mode cards can run in IOP-less mode in attached I/O towers
- ▶ An IXS can be placed in the 1.9 GHz Model 520 system unit. An IXS continues to require an IOP.
- ▶ Conversions between direct attach, IOP- required, and IOP-less features are available.
- ▶ Controllers are auto-configured as IOP-less when possible.

There are three types of IOA features announced for System i processors that run with i5/OS and one IOA type that runs with AIX or Linux. The four types of IOAs are:

- ▶ IOAs that require IOPs.
- ▶ Single mode IOP-less IOAs that are not recognized by IOPs. These IOAs can be placed virtually anywhere relative to installed IOPs without causing problems.
- ▶ Dual mode IOP-less IOAs that can run without an IOP and can make use of an IOP for performance reasons.

If an IOP controls the IOA, order the IOA by the column A feature code. Place the IOA after an IOP on the same EADs boundary. To run in IOP-less mode, place the dual mode IOA in front of (that is, in a lower) EADs address of any IOP in an EADs.

- ▶ Direct access IOAs run without an IOP. They are used in a System i AIX or Linux partition.

The four types of IOAs are represented in Table 4-1 on page 186 as follows:

- ▶ Column A shows IOAs that require IOPs. An IOP is required for i5/OS.
- ▶ Column B shows direct attach features that allow the use of the IOA in an AIX or Linux partition without an IOP.
- ▶ Column C shows single-mode IOP-less features.
- ▶ Column D shows that operate IOP-less in an i5/OS partition.
- ▶ Columns E through G show the functionality of the hardware in that row at the various i5/OS Version 5 releases.
- ▶ Dedicated means the IOA must be driven by an IOP.

- ▶ Both means the IOA can run with or without an IOP. Proper placement depends on which feature is ordered. When a Column D feature is ordered, it must be placed either in an EADs without any IOPs, or ahead of any IOPs in the same EADs. When a Column A feature is ordered, it must be placed after an IOP on the same EADs so that it can be controlled by the IOP.

Table 4-1 IOP-less support

IOP required A	Direct attach B	Single mode IOP-less C	Dual mode IOP-less D	V5R3M0 and previous E	V5R3M5 F	V5R4M0 G
#2793 #2794 #9793 #9794	#0614 #0615		#9493 #9494	Dedicated	Both *	Both *
#5700 #5701	#0620 #0621		#6800 #6801	Dedicated	Dedicated	Both
#5727 #5728	n/a		#5727 #5728	Dedicated	Both	Both
#5736	#0647		#5775	Dedicated	Both	Both
#5737	#0648		#5776	Dedicated	Both	Both
IOP-less only		#4806 #5706 #5707 #5721 #5722	IOP-less only			
* Can be IOP-less when used for ECS.						

Each row in Table 4-1 represents a hardware entity. All feature codes within any given row pertain to exactly the same hardware. The reported CCIN for any feature in any given row is the same.

Note: Do not place the #6800 PCI 1Gbps Ethernet IOA or #6801 PCI 1Gbps Ethernet UTP IOA in a #5704 PCI-X Fibre Channel Tape Controller or #5079 1.8 m I/O Tower.

Table 4-2 IOP-less features

Group	Description	FC**	Initial i5/OS IOP-less release
LAN	PCI 1 Gbps Ethernet Fiber 2-port	#5707	V5R3M0
	PCI 10/100/1000 Mbps Ethernet UTP 2-port	#5706	V5R3M0
	PCI 1 Gbps Ethernet IOA	#5700/#6800	V5R4M0
	PCI 1 Gbps Ethernet UTP IOA	#5701/#6801	V5R4M0
	PCI-xddr 10 Gbps Ethernet Fiber	#5722	V5R4M0
	PCI-xddr 10 Gbps Ethernet Fiber	#5721	V5R4M0

Group	Description	FC**	Initial i5/OS IOP-less release
Storage controller	PCI-X DDR U320 RAID Disk Ctrl with Read Cache	#5738/#0649	V5R4P
	PCI-X DDR U320 RAID Disk Ctrl with Read Cache	#5739/#5746/#0650/#0651	V5R4P
	PCI-X DDR Auxiliary Cache IOA	n/a	V5R4P
	PCI-X DDR U320 Tape/DASD Ctlr	#5775/#5736	V5R3M5
	PCI-X DDR U320 RAID Disk Unit Ctlr	#5776/#5737	V5R3M5
	64 MB Planar RAID feature Card	#5727/#5728	V5R3M5
WAN	PCI 2-Line WAN w/Modem	#2793/#6803	V5R3M5
	PCI 2-Line WAN w/Modem (CIM)	#2794/#6801	V5R3M5
	PCI 2-Line WAN IOA	#2742/#6805	V5R4M5
	PCI Quad Modem IOA	#2805/#6808	V5R4M5
	PCI Quad Modem IOA (CIM)	#2806/#6809	V5R4M5
Encryption	PCI-x Encryption	#4806	V5R3M0
IXA	iSCSI IXA Adapter Opt without IPSEC	#5783	V5R4P
	iSCSI IXA Adapter Cu without IPSEC	#5784	V5R4P
Disk	35.16 GB 10K RPM Disk Unit	#4319/#7504	V5R3M5
	8.58 GB 10K RPM Disk Unit	#4317/#7501	V5R3M5
	70.56 GB 15K RPM Disk Unit	#4327/#7509	V5R3M5
	35.16 GB 15K RPM Disk Unit	#4326/#7508	V5R3M5
	17.54 GB 10K RPM Disk Unit	#4318/#7502	V5R3M5
	141 GB Ultra320 15K RPM U320	#4328/#7510	V5R3M5

Group	Description	FC**	Initial i5/OS IOP-less release
Removable Optical internal device	DVD ROM Slimline	#2640	V5R3M5
	DVD-RAM	#4430	V5R3M5
	DVD-RAM	#4630	V5R3M5
	DVD RAM Slimline	#5751	V5R3M5
	DVD-RAM	#4633	V5R3M5
	DVD-ROM	#4631	V5R3M5
	VXA-2 80 GB Tape	#4685	V5R3M5
	VXA-2 80 GB Tape	#1889	V5R3M5
	VXA-3 160 GB Tape	#4688	V5R3M5P
	VXA-3 160 GB Tape	#5764	V5R3M5P
	QIC 50 GB Tape	#5754	V5R3M5
	QIC 50 GB Tape	#4487	V5R3M5
	QIC 50 GB Tape	#4687	V5R3M5
	QIC 30 GB Tape	#5753	V5R3M5
	QIC 30 GB Tape	#4684	V5R3M5
	DAT 160 GB 4 mm Tape	#6259	V5R4P
	HH LTO2	#5755	V5R3M5
Removable External Optical Device	DVD RAM Bridge Box		V5R3M5
	DVD-RAM Bridge Box		V5R3M5
	DVD-RAM	#1102	V5R3M5
	DVD-RAM	#1103	V5R3M5
	DVD-ROM	#1106	V5R3M5
Removable Optical Library Device	Opt Lib (Plasmon 14x and/or UDO G-Series 24 to 638)		V5R4M0
	Optical Library (IBM UDO Models 32, 80, 174)		V5R4M0

Group	Description	FC**	Initial i5/OS IOP-less release
External Removable Tape Device	SLR60, QIC 30 GB BBox		V5R3M5
	VXA-2 80 GB BBox		V5R3M5
	VXA-3 160 GB Tape BBox		V5R3M5P
	DAT 160 GB Tape BBox		V5R4P
	SLR60, QIC 30 GB		V5R3M5
	SLR100, QIC 50 GB		V5R3M5
	VXA-2 80 GB		V5R3M5
	VXA-3 160 GB Tape		V5R3M5P
	HH LTO2		V5R3M5
	DAT 160 GB Tape		V5R4P
Removable Tape Library	FC Library Expansion Frame for 3592 J1A		V5R4M5
	FC Library High Availability Redundant Library Manager and Picker		V5R4M5
	FC Library Base Frame for 3590 E1A,H1A Drives		V5R4M5
	FC Library Base Frame for 3592 J1A		V5R4M5
	LTO2 LVD BBox		V5R4M5
	LTO3 LVD BBox		V5R4M5
	LTO2 LVD 5u 7Cart ACL		V5R4M5
	LTO2 FC 2u 8Cart ACL		V5R4M5
	LTO3 FC 2u 8Cart ACL		V5R4M5
	LTO2 LVD 2u 8Cart ACL		V5R4M5
	LTO3 LVD 2u 8Cart ACL		V5R4M5
	LTO2 FC 23Cart Libr		V5R4M5
	LTO3 FC 23Cart Libr		V5R4M5
	LTO2 LVD 1-6Drv 18-72Cart Libr (Belgian)		V5R4M5
	LTO2 FC 1-6Drv 18-72Cart Libr (Belgian)		V5R4M5
LTO3 LVD 1-6Drv 18-72Cart Libr (Belgian)		V5R4M5	

Group	Description	FC**	Initial i5/OS IOP-less release
Removable Tape Library	LTO3 FC 1-6Drv 18-72Cart Libr (Belgian)		V5R4M5
	UltraScalable Library LTO3 FC drive canister		V5R4M5
	UltraScalable Libr LTO3 LVD drive canister		V5R4M5
	UltraScalable Library FC drive canister (3592-J1A)		V5R4M5
	UltraScalable Library FC drive canister		V5R4M5
	UltraScalable Library LTO3 LVD drive canister		V5R4M5
	UltraScalable Libr LTO3 FC drive canister		V5R4M5
	UltraScalable Library LTO2 LVD drive canister		V5R4M5
	UltraScalable Library LTO2 FC drive canister		V5R4M5
	UltraScalable Library LTO2 FC drive		V5R4M5
	300 GB 40 MBps FC drive Worm		V5R4M5
	300 GB 40 MBps FC drive Worm		V5R4M5
WAN Protocol	PPP for ECS		V5R3M5
	PPP for non-ECS		V5R4M5
	Asynchronous		V5R4M5
	Bisynchronous		V5R4M5
Ethernet Protocol	IP		V5R3M0
	Console - Ethernet embedded		V5R4M0
	Console		V5R4M0

4.7 Workstation controllers and console features

Workstation controllers and console features	
#4746 #9746	<p>#4746 PCI Twinaxial IOA</p> <p>The #4746 PCI Twinaxial IOA provides support for up to 40 active twinaxial displays and printers addresses or up to 120 active shared sessions. A 20-foot (6.2 m) cable with an eight-port expansion (breakout) box is included with this adapter. Each port supports seven attached devices, allowing for 56 total attached devices, of which only 40 can be active.</p> <p>The #9746 Base PCI Twinaxial IOA is allowed only on new systems. If the client does not select the feature on the initial order, they are not entitled to receive the feature in the future. The #9746 requires an #0864 and a #7400.</p> <p>Supported on Models 520, 550, 570, 595, 800, 810, 820, 825, 830, 840, 870, and 890. The #4746 is a Customer Install Feature. The #9746 is withdrawn from marketing as of 01 October 2005.</p>
#5540	<p>#5540 System Console on Twinaxial Workstation IOA</p> <p>A system console specify code must be selected on each new order. When the #5540 is on the order, the system console is driven by a #4746 PCI Twinaxial IOA.</p> <p>Supported on Models 520, 550, 570, 595, 800, 810, 820, 825, 830, 840, 870, and 890.</p>

#5544	<p>#5544 System Console on Operations Console A system console specify code must be selected on each new order. When a #5544 is specified, the primary i5/OS system console is driven by an IOP-based WAN adapter. The system console can be connected to a #0367 Operations Console PCI Cable attached to a #4745 PCI 2-line WAN IOA or a #9771/#9793/#9794 Base PCI 2-Line WAN with integrated modem.</p> <p>Supported on Models 520, 550, 570, 595, 800, 810, 820, 825, 830, 840, 870, and 890.</p>
#5546	<p>#5546 System Console on 100 Mbps Token Ring A system console specify code must be selected on each new order. When the #5546 is on the order, the system console is LAN attached to a #2744 PCI 100 Mbps Token Ring IOA. This LAN adapter must be dedicated to console functions and cannot be used for any other purpose. One #0367 Operations Console PCI Cable is required to be on the order or present on the system. One #0367 per system is sufficient, regardless of the number of "LAN consoles" (via LPAR) defined per system.</p> <p>Minimum operating system level: OS/400 V5R1 Supported on Models 520, 550, 570, 595, 800, 810, 820, 830, 840, 870, and 890.</p>
#5548	<p>#5548 System Console on 100 Mbps Ethernet A system console specify code must be selected on each new order. When the #5548 is on the order, the system console is LAN attached to a #4838 PCI 100/10 Mbps Ethernet IOA or a #2849 10/100 Mbps Ethernet Adapter. This LAN adapter must be dedicated to console functions and cannot be used for any other purpose. The #5548 is specifically used for IOP-based IOAs.</p> <p>The embedded Ethernet ports on the Model 520, 550 and 570 system units cannot be used for LAN console when running under i5/OS V5R3. See #0553 specify code. One #0367 Operations Console PCI Cable is required to be on the order or present on the system. One #0367 per system is sufficient, regardless of the number of "LAN consoles" (via LPAR) defined per system.</p> <p>Minimum operating system level: OS/400 V5R1 Supported on Models 520, 550, 570, 595, 800, 810, 820, 825, 830, 840, 870, and 890.</p>
#5550	<p>#5550 System Console on HMC A system console specify code must be selected on each new order. When the #5550 is on the order, the system console function is driven by the HMC via an Ethernet connection to a dedicated HMC port on the system unit. The HMC is required for LPAR, Capacity Upgrade on Demand, Concurrent Maintenance and Upgrade and Redundant Service Processor (SP) operations.</p> <p>Minimum operating system level: i5/OS V5R3 Supported on Models 520, 550, 570, and 595.</p>
#5553	<p>#5553 System Console Ethernet w/o IOP A system console specify code must be selected on each new order. When the #5553 System Console Ethernet w/o IOP is on the order, it indicates the use of an embedded system unit LAN port for the system console connection using Operations Console (LAN). This LAN port is then dedicated to the console function and no longer available for other functions.</p> <p>Minimum operating system level: i5/OS V5R4 for Models 520, 550, 550+, 570, 570+; or i5/OS V5R3 with LIC V5R3M5 on Model 520+ Supported on Models 520, 520+, 550, 550+, 570, and 570+</p>
#5557	<p>#5557 System Console Ethernet w/o IOP The #5557 provides a system console connection through an IOP-less ethernet LAN adapter. A system console specify code must be selected on each new order. This LAN adapter must be dedicated to console support functions and cannot be used for any other purpose. A #5706 or #5707 PCI-X IOP-less ethernet LAN adapter is required.</p> <p>Minimum operating system level: i5/OS V5R4 Supported on Model 595.</p>

4.8 LAN and WAN adapters

LAN and WAN adapters	
Comm. Restrictions	Restrictions apply when using specific adapters and I/O processors. See "Comm. Restrictions" on page 193, for communications rules and restrictions. Also see <i>PCI and PCI-X Placement Rules for IBM System i5, eServer i5, and iSeries servers with i5/OS V5R4 and V5R3</i> , REDP-4011 or <i>PCI Card Placement Rules for the IBM eServer iSeries Server OS/400 Version 5 Release 2: September 2003</i> , REDP-3638, for further placement rules.

Comm. Restrictions	<p>Basic communications restrictions when using the MFIOP, #2629, #2699, #2720, #2721, #2745, #2809, #2824, and other communications functions are identified here. This information is a brief summary.</p> <ul style="list-style-type: none"> ▶ Maximum protocol speeds on the EIA-232/ITU V.24 electrical interfaces: <ul style="list-style-type: none"> – 64 Kbps for Synchronous PPP, BSC, SDLC, and X.25 – 115.2 Kbps for Asynchronous protocols (including Asynchronous PPP) ▶ Maximum protocol speeds on the ITU V.35: <ul style="list-style-type: none"> Permitted only on 20-ft (6.2 m) cable – 2.048 Mbps for Synchronous PPP, SDLC, and Frame Relay – 230.4 Kbps for Asynchronous PPP – 640 Kbps for X.25 – 64 Kbps for BSC <p>Speeds faster than 512 Kbps can require either the “looped” or “inverted” clocking to be configured.</p> ▶ Maximum protocol speeds on the EIA-449/ITU V.36: <ul style="list-style-type: none"> – 2.048 Mbps for Synchronous PPP, SDLC, and Frame Relay – 230.4 Kbps for Asynchronous PPP – 640 Kbps for X.25 – 64 Kbps for BSC <p>“Looped” clocking is required on cables longer than 20 ft (6 m). Speeds faster than 512 Kbps can require either the “looped” or “inverted” clocking to be configured.</p> ▶ Maximum protocol speeds on the ITU X.21 electrical interfaces: <ul style="list-style-type: none"> Permitted only on 20-ft (6.2 m) cable – 2.048 Mbps for Synchronous PPP, SDLC, and Frame Relay – 640 Kbps for X.25 <p>Speeds faster than 512 Kbps can require either the “looped” or “inverted” clocking to be configured.</p> ▶ Only one Frame Relay or one X.25 communication line is allowed per IOP. ▶ One high-speed line is permitted per IOP. ASYNC and ASYNC PPP above 115.2 Kbps is a high-speed line. Frame Relay, SDLC, SYNC PPP, and X.25 above 64 Kbps is a high-speed line. High-speed lines are supported on ITU X.21, ITU V.35 20-ft (6 m) cables, or EIA-449/ITU V.36 electrical interfaces. ▶ No high-speed communication line is allowed when a #2750, #2751, or #2761 is installed under the same I/O processor. ▶ If it is desired to run multiple emulated LAN lines on an #281x ATM IOA, then the following restrictions must be satisfied: <ul style="list-style-type: none"> – The #281x ATM IOA must be running under a dedicated #2824 PCI Feature Controller (no other IOAs of any type). – The number of emulated LANs running on the #281x ATM IOA is limited to a maximum of two, one token ring and one Ethernet. ▶ Frame Relay restrictions: <ul style="list-style-type: none"> – Minimum line speed 56 Kbps – Frame Relay is not allowed on EIA-232/V.24 electrical interface ▶ Other IOAs allowed under same #2809 PCI LAN/WAN/Workstation IOP or #2824 PCI Feature Controller, one of two restrictions: <ul style="list-style-type: none"> – Either a #281x or #2838 – A #2718 or #2729 and maximum of one #2721, #2722, #2723, #2724, #2729, #2745, or #2746 ▶ IPX™ is supported on Frame Relay, LAN, and ATM. <ul style="list-style-type: none"> – IPX is supported only on OS/400 V5R1 and earlier, not on OS/400 V5R2. – Devices running IPX over the Integrated xSeries Server is limited to 2400 routes and 2400 services. – Devices running IPX are limited to 1400 routes and 1400 services when: <ul style="list-style-type: none"> • #2723, #2724, or #2838 IOAs are not controlled by the Integrated xSeries Server. • Frame Relay running over a #2721, #2745, or #2699 IOA. ▶ SDLC restrictions: <ul style="list-style-type: none"> – Maximum of 64 remote locations per #2809, #2824, or #2629 IOP. ▶ X.25 restrictions: <ul style="list-style-type: none"> – Limit of 16 virtual circuits (16 remote locations). – Limit of 64 virtual circuits (64 remote locations) in the #5065 Storage/PCI Expansion Tower. – Speeds faster than 512 Kbps can require either “looped” or “inverted” clocking to be configured. – The other port of the #2721 or #2745 can be used as a low-speed communications line. ▶ Not allowed on the #2720/#9720 if this combination of adapters is installed on the base MFIOP: <ul style="list-style-type: none"> – #2722 or #2746 plus one #2723 or #2724 ▶ No more than seven #2629s can be placed into each #5072 1063 Mbps System Unit Expansion Tower. ▶ Bisync is always limited to a maximum of 64 Kbps.
--------------------	---

<p>Comm. Restrictions (cont.)</p>	<p>Continued,</p> <p>Additional restrictions include:</p> <ul style="list-style-type: none"> ▶ V.25 autocal cable is not supported. ▶ Select standby mode is not supported. ▶ #2750, #2751, #2761, #4750, #4751, #4761 are not supported with i5/OS V5R3 ▶ #2817, #481x #28x ATM not supported. Upgrade to Ethernet. <p>Notes:</p> <ul style="list-style-type: none"> ▶ It is imperative that these restrictions be understood and followed. If they are not followed, it is possible that a hardware configuration could be built that marginally works, and later quits working when the machine is upgraded to future software releases. ▶ For best performance, we recommend that no other features be intermixed with a #2838 PCI 100/10 Mbps Ethernet IOA or a #2811, #2812, #2815, #2816, #2818, or #2819 ATM IOA on a #2809 PCI LAN/WAN/Workstation IOP. <p>The quantity and speed of each communications line must be known. Complete this table to determine the total communications CPW required. The #2750, #2751, and #2761 count as eight low-speed communications lines.</p> <p>Maximum High-Speed Communication lines Calculation Table</p> <table border="1" style="width: 100%; border-collapse: collapse;"> <thead> <tr> <th></th> <th style="text-align: center;">Quantity</th> <th style="text-align: center;">Factor</th> <th style="text-align: center;">CPW</th> </tr> </thead> <tbody> <tr> <td>Number of lines operating at 64 Kbps or less</td> <td style="text-align: center;">_____</td> <td style="text-align: center;">x 0.92</td> <td style="text-align: center;">= _____</td> </tr> <tr> <td>Number of lines operating above 64 Kbps up to 128 Kbps</td> <td style="text-align: center;">_____</td> <td style="text-align: center;">x 1.84</td> <td style="text-align: center;">= _____</td> </tr> <tr> <td>Number of lines operating above 128 Kbps up to 256 Kbps</td> <td style="text-align: center;">_____</td> <td style="text-align: center;">x 3.68</td> <td style="text-align: center;">= _____</td> </tr> <tr> <td>Number of lines operating above 256 Kbps up to 512 Kbps</td> <td style="text-align: center;">_____</td> <td style="text-align: center;">x 7.36</td> <td style="text-align: center;">= _____</td> </tr> <tr> <td>Number of lines operating above 512 Kbps up to 1,024 Kbps</td> <td style="text-align: center;">_____</td> <td style="text-align: center;">x 14.72</td> <td style="text-align: center;">= _____</td> </tr> <tr> <td>Number of lines operating above 1,024 Kbps up to 2,048 Kbps</td> <td style="text-align: center;">_____</td> <td style="text-align: center;">x 29.44</td> <td style="text-align: center;">= _____</td> </tr> <tr> <td></td> <td></td> <td style="text-align: center;">Total</td> <td style="text-align: center;">_____</td> </tr> </tbody> </table> <p>For more information, refer to <i>iSeries Performance Capabilities Reference</i>, SC41-0607.</p>		Quantity	Factor	CPW	Number of lines operating at 64 Kbps or less	_____	x 0.92	= _____	Number of lines operating above 64 Kbps up to 128 Kbps	_____	x 1.84	= _____	Number of lines operating above 128 Kbps up to 256 Kbps	_____	x 3.68	= _____	Number of lines operating above 256 Kbps up to 512 Kbps	_____	x 7.36	= _____	Number of lines operating above 512 Kbps up to 1,024 Kbps	_____	x 14.72	= _____	Number of lines operating above 1,024 Kbps up to 2,048 Kbps	_____	x 29.44	= _____			Total	_____
	Quantity	Factor	CPW																														
Number of lines operating at 64 Kbps or less	_____	x 0.92	= _____																														
Number of lines operating above 64 Kbps up to 128 Kbps	_____	x 1.84	= _____																														
Number of lines operating above 128 Kbps up to 256 Kbps	_____	x 3.68	= _____																														
Number of lines operating above 256 Kbps up to 512 Kbps	_____	x 7.36	= _____																														
Number of lines operating above 512 Kbps up to 1,024 Kbps	_____	x 14.72	= _____																														
Number of lines operating above 1,024 Kbps up to 2,048 Kbps	_____	x 29.44	= _____																														
		Total	_____																														
<p>#0632</p>	<p>#0632 PCI USB 2.0 Adapter</p> <p>The #0632 is a USB 2.0 capable adapter that provides for the connection of one USB keyboard and mouse.</p> <p>Supported in Linux and AIX partitions with SUSE Linux Enterprise Server 9 for POWER or Red Hat Enterprise Linux AS for POWER Version 3, or AIX 5L for POWER V5.2. Support is limited to USB 1.1 with AIX.</p> <p>Supported on Models 520, 550, 570, and 595.</p>																																
<p>#0633</p>	<p>#0633 Graphics Adapter</p> <p>The #0633 POWER GXT135P Graphics Accelerator with Digital Support adapter is a versatile 2D graphics accelerator which can be configured to operate in either 8-bit or 24-bit color modes. The #0633 supports both analog and digital monitors.</p> <p>Minimum operating system level: AIX Versions 5.1 or 5.2 for analog and digital support</p> <p>Supported on Models 520, 550, 570, and 595.</p>																																
<p>#0634</p>	<p>#0634 128-port Asynchronous Adapter</p> <p>The #0634 provides attachment for up to 128 asynchronous lines from a single PCI bus slot. This gives the system the ability to serve a large number of user of EIA-232 or RS-422 devices such as terminals, printers, and modems.</p> <p>Two 2.4 Mbps synchronous channels link the adapter to a maximum of eight 16-Port Remote Async Nodes (RANs). Up to four RANs can be linked to each synchronous channel. RANs can also be used with this adapter. If the RANs are connected the synchronous channel the data rate drops down to 1.2 Mbps. For the best results keep the previous and new RANs on separate synchronous channels.</p> <p>One PCI slot and a #0140 Logical Partitioning Specify and #0145 AIX Partition Specify are required.</p> <p>Supported in Linux and AIX partitions with AIX 5L for POWER V5.2, or AIX 5L for POWER V5.2</p> <p>Supported on Models 520, 550, 570, and 595.</p> <p>The #0634 is withdrawn from marketing as of 01 December 2005</p>																																

#0635	<p>#0635 SDLC/X.25 - 2-port Adapter</p> <p>The #0635 SDLC/X.25 - 2-port Adapter provides high-speed connections between stand-alone system units on a WAN. To access WAN lines, the #0635 adapter connects via external communications equipment including Channel Service Units (CSU), Data Service Units (DSU).</p> <p>This adapter together with IBM AIX link/X.25 provides a two-port connection to X.25 packet switched networks. IBM AIXlink/X.25 is a separately orderable LPP (5696-926).</p> <p>The #0635, with an appropriate cable, is compatible with:</p> <ul style="list-style-type: none"> ▶ #2954 X.21 DCE - Using 2-Port Cable, X.21 ▶ CCITT X.21 Signalling ▶ CCITT V.11 Electrical ▶ CCITT X.27 Electrical ▶ EIA-422-A Electrical ▶ ISO 4903 Connector for DCE side of an X.21 VHSI Modem Cable ▶ V.24 DCE - Using 2-Port Cable, V.24/EIA-232 (#2951) ▶ CCITT V.24 Signalling ▶ CCITT V.28 Electrical ▶ CCITT X.21bix Electrical and Signalling ▶ EIA-232-C Electrical and Signalling ▶ ISO 2110 Connector for DCE side of an V.24 VHSI Modem Cable ▶ V.35 DCE - Using 2-Port Cable, V.35 (#2952) ▶ CCITT V.35 Some signals for signalling ▶ CCITT V.28 Some signals for electrical and signalling ▶ ISO 2593 Connector for DCE side of an V.35 VHSI Modem Cable ▶ V.36 DCE - Using 2-Port Cable, V.36/EIA-449 (#2953) ▶ CCITT V.10 Electrical ▶ CCITT V.11 Electrical <p>One PCI slot, #0140 Logical Partitioning Specify and #0145 AIX Partition Specify code is required.</p> <p>Supported on Models 520, 550, 570, and 595. The #0635 is withdrawn from marketing as of 01 December 2005.</p>
-------	--

<p>#2742</p>	<p>#2742 2-Line WAN IOA</p> <p>The #2742 2-Line WAN IOA is a WAN IOA that supports up to two multiple protocol communications (RVX) ports when one or two (in any combination) of the following cables are attached. Select one of the following cables to attach to port 1 or 2 (RVX port):</p> <ul style="list-style-type: none"> ▶ #0348 V.24/EIA232 20-ft (6 m) PCI cable ▶ #0349 V.24/EIA232 50-ft (15 m) PCI cable ▶ #0353 V.35 20-ft PCI cable ▶ #0354 V.35 50-ft PCI cable ▶ #0355 V.35 80-ft/24m PCI cable ▶ #0356 V.36 20-ft PCI cable ▶ #0358 V.36 150-ft/45m PCI cable ▶ #0359 X.21 20-ft PCI cable ▶ #0360 X.21 50-ft PCI cable ▶ #0365 V.24/EIA232 80-ft PCI cable ▶ #0367 Operations Console PCI Cable <p>The #0367 cable ships with a 25 pin to 9 pin adapter. When #0140 Logical Partitioning Specify is ordered, multiple #0367 cables can be ordered to connect the operations console in each partition. One #0367 cable per #2742.</p> <p>When #2742 is selected to support ECS, one of following cables must be specified:</p> <ul style="list-style-type: none"> ▶ #0348 V.24/EIA232 20-ft (6 m) PCI cable ▶ #0349 V.24/EIA232 50-ft (15 m) PCI cable ▶ #0367 Operations Console PCI Cable <p>The #2742 can be directly attached to a Linux partition. When ordered as #0613 - Direct Attach #2742 PCI 2-Line WAN IOA, an IOP is not required. When directly attached to a Linux partition, the #2742 cannot be accessed by OS/400 partitions.</p> <p>The #2742 does not support Remote Power On.</p> <p>Minimum operating system level: OS/400 V5R2 Supported on Models 270, 520, 550, 570, 595, 800, 810, 820, 825, 830, 840, 890, SB2, SB3, and 9411-100. The #2742 is a Customer Install Feature.</p>
<p>#2743</p>	<p>#2743 1 Gbps PCI Ethernet IOA</p> <p>The #2743 PCI 1 Gbps Ethernet IOA feature allows the iSeries server to attach to IEEE standard 802.3Z high speed Ethernet LANs (1 Gbps). It can also be used to connect to existing 100 Mbps Ethernet LANs using switches with 10/100/1000 Mbps ports.</p> <p>The adapter supports multi-mode fiber media attachment to client-supplied cabling. The multi-mode interface has a 62.5/125 micron or 50.0/125 micron cable requirement with an SC connector.</p> <p>The #2743 requires a gigabit-capable switch with at least one port that supports a 1000BASE-SX interface with IEEE 802.3z and 802.3u compliance. It supports only a multi-mode fiber optic cable connection from the adapter to the switch. The #2743 supports 1000 Mbps (1 Gbps) full duplex interface only. Cannot negotiate down to a lower speed. Stations on the 10 Mb and 100 Mb switched LANs can communicate with the #2743 through a switch that is capable of handling all these speeds. In this case, the switch handles the speeds.</p> <p>If a #2743 is controlled by a #2790, #2791, or #2799, then one specify code #0225 1 Gbps Ethernet Specify must be ordered for each #2743 controlled by an Integrated Server. It can be directly attached to a Linux partition. When ordered as #0601 - Direct Attach #2743 PCI 1 Gbps Ethernet IOA, an IOP is not required. When directly attached to a Linux partition, the #2743 cannot be accessed by OS/400 partitions.</p> <p>A 64-bit card slot is required. Protocols supported: TCP/IP only; SNA and IPX connections are not supported Maximum: One per Multi-adapter Bridge Boundary</p> <p>Minimum operating system level: OS/400 V4R5 Minimum operating system level, when used with the #2790/#2791: OS/400 V4R5 with Cumulative PTF package C1005450 Minimum operating system level: when used with the #2799: OS/400 V5R1 with PTFs identified in Information APAR I113105 at: http://www-03.ibm.com/servers/eserver/support/series/index.html Supported on Models 270, 9406 520, 550, 570, 595, 810, 820, 830, 840, 870, 890, SB2, SB3, and 9411-100. The #2743 is a Customer Install Feature. The #2743 is withdrawn from marketing as of 01 October 2004. A #5700 is the recommended replacement.</p>

#2744	<p>#2744 PCI 100 Mbps Token Ring IOA</p> <p>The #2744 PCI 100 Mbps Token Ring IOA provides a single attachment to a 100 Mbps, 16 Mbps, or 4 Mbps IBM Token Ring Network. The feature consists of an IOA card, with internal code that supplies IEEE 802.5 Media Access Control (MAC) and IEEE 802.2 Logical Link Control (LLC) functions. The 100/16/4 Token Ring IOA is capable of operating in half or full duplex mode. A 2.44m (8 ft) Token Ring Type 1 cable is included with the #2744. As an alternative, the client can attach a separately priced twisted pair cable to the RJ45 connection on the IOA. IBM Cabling System patch cables, included with the #2744, can increase the length as required. If the #2744 is selected to run on the #2790 PCI Integrated Netfinity Server or the #2791/#2799 PCI Integrated xSeries Server, a #0223 100 Mbps Token-Ring Specify is required for each #2744 selected to run on the #2790, #2791, or #2799.</p> <p>The #2744 can be directly attached to a Linux partition. When ordered as #0603 - Direct Attach #2744 PCI 100 Mbps Token-Ring IOA, an IOP is not required. When directly attached to a Linux partition, the #2744 cannot be accessed by OS/400 partitions.</p> <p>Minimum operating system level: OS/400 V4R5 Supported on Models 270, 520, 550, 570, 595, 800, 810, 820, 825, 830, 840, 870, 890, SB2, SB3, and 9411-100. The #2744 is a Customer Install Feature. The #2744 is withdrawn from marketing as of 01 June 2006.</p>
#2760	<p>#2760 PCI 1 Gbps Ethernet UTP Adapter</p> <p>The #2760 PCI 1 Gbps Ethernet UTP Adapter feature allows the iSeries server to attach to IEEE standard 802.3Z high-speed Ethernet LANs (1 Gbps) to provide a significant performance improvement over other LAN solutions. The adapter supports a UTP CAT 5 media interface. When driven by a #2843 PCI IOP, this adapter only supports TCP/IP. This adapter can directly attach to 10 Mbps or 100 Mbps networks. The #2760 is supported by a #2790/#2791/#2799 PCI Integrated xSeries Server. If a #2760 is controlled by a #2790, #2791, or #2799, then one specify code #0225 1 Gbps Ethernet Specify must be ordered for each #2760 controlled by an Integrated Server.</p> <p>Maximum: One per Multi-adapter Bridge Boundary. Ignore this maximum for any #2760 controlled (driven) by an Integrated xSeries Server. Combinations of Integrated Server controlled and PCI IOP controlled #2760s within Multi-adapter Bridge boundaries are permitted.</p> <p>The #2760 can be directly attached to a Linux partition. When ordered as #0602 - Direct Attach #2760 PCI 1 Gbps Ethernet UTP IOA, an IOP is not required. When directly attached to a Linux partition, the #2760 cannot be accessed by OS/400 partitions.</p> <p>One 64-bit PCI slot is required. There are exceptions for 32-bit slot placement in the Model 270 and 820 system units. TCP/IP is the only protocol supported. SNA and IPX connections are not supported.</p> <p>Minimum operating system level: OS/400 V5R1 Supported on Models 270, 9406 520, 550, 570, 595, 810, 820, 825, 830, 840, 870, 890, SB2, SB3, and 9411-100. The #2760 is a Customer Install Feature. The #2760 is withdrawn from marketing as of 01 October 2004. A #5701 is the recommended replacement.</p>

#2772	<p>#2772 PCI Dual WAN/Modem IOA</p> <p>The #2772 PCI Dual WAN/Modem IOA is a 2-line WAN adapter, with two ports (RJ11) supporting V.90 56K Async PPP and Fax applications at data rates up to 14.4K via internal modems. Connection to the V.90 ports is via telephone cable. This is the non-Complex Impedance Matching (CIM) version of the #2772/#2773 card.</p> <p>The #2772 can be directly attached to a Linux partition. When ordered as #0609 - Direct Attach #2772 PCI Dual WAN/Modem IOA, an IOP is not required. When directly attached to a Linux partition, the #2772 cannot be accessed by OS/400 partitions.</p> <p>The #2772 does <i>not</i> ship with country-specific or region-specific telephone cables. A minimum of one modem cable, or a maximum of two, must be selected/ordered for each #2772. All modem cables ordered or present on a system must be the same feature number.</p> <ul style="list-style-type: none"> ▶ #1010 Modem Cable-Austria ▶ #1011 Modem Cable-Belgium ▶ #1012 Modem Cable-Africa ▶ #1013 Modem Cable-Israel ▶ #1014 Modem Cable-Italy ▶ #1015 Modem Cable-France ▶ #1016 Modem Cable-Germany ▶ #1017 Modem Cable-United Kingdom ▶ #1018 Modem Cable-Iceland/Sweden ▶ #1021 Modem Cable-Finland/Norway ▶ #1022 Modem Cable-Netherlands ▶ #1023 Modem Cable-Swiss ▶ #1024 Modem Cable-Denmark ▶ #1025 Modem Cable-U.S./Canada <p>The feature is country-specific or region-specific. Remote ring indicate is not supported. One PCI card slot is required.</p> <p>Minimum operating system level: OS/400 V5R1 Supported on Models 270, 520, 550, 570, 595, 800, 810, 820, 825, 830, 840, 870, 890, SB2, SB3, and 9411-100. The #2772 is a Customer Install Feature. The #2772 is withdrawn from marketing 01 June 2006.</p>
#2773	<p>#2773 PCI Dual WAN/Modem IOA</p> <p>The #2773 is a 2-line WAN adapter, with two ports (RJ11) supporting V.90 56K Async PPP and Fax applications at data rates up to 14.4K via internal modems. Connection to the V.90 ports is via telephone cable. This is the CIM version of this #2772/#2773 card.</p> <p>The #2773 can be directly attached to a Linux partition. When ordered as #0610 - Direct Attach #2773 PCI Dual WAN/Modem IOA, an IOP is not required. When directly attached to a Linux partition, the #2773 cannot be accessed by OS/400 partitions.</p> <p>The #2773 does <i>not</i> ship with country-specific or region-specific telephone cables. A minimum of one modem cable, or maximum of two, must be selected or ordered for each #2773. All modem cables ordered or present on a system must be the same feature number.</p> <ul style="list-style-type: none"> ▶ #1019 Modem Cable-Australia ▶ #1020 Modem Cable-China (Hong Kong S.A.R.)/New Zealand <p>The feature is country-specific or region-specific. Remote ring indicate is not supported. PCI card slots required: One</p> <p>Minimum operating system level: OS/400 V5R1 Supported on Models 270, 520, 550, 570, 595, 800, 810, 820, 825, 830, 840, 870, 890, SB2, SB3, and 9411-100. The #2773 is a Customer Install Feature.</p>

<p>#2793 #9793 #2793 #9793</p>	<p>#2793 2-Line WAN IOA with Modem</p> <p>The #2793/#9793 is a 2-Line WAN with modem adapter and is the non-CIM version that is offered in all countries or regions except Australia and New Zealand. Port 0 is the modem port and supports V.92 56K Async PPP, V.92 data modem, V.44 data compression, and V.34 Fax modem and Fax functions such as ECM and 2D/1D conversion. Port 0 does not provide sync modem capabilities (SDLC and Sync PPP). Port 1 is the RVX port and supports multiple communications protocols.</p> <p>The #2793 can be directly attached to a Linux partition. When ordered as #0614 - Direct Attach #2793 PCI 2-Line WAN w/Modem, an IOP is not required. When directly attached to a Linux partition, the #2793 cannot be accessed by OS/400 partitions.</p> <p>Select one of the following cables to attach to port 0 (modem port):</p> <ul style="list-style-type: none"> ▶ #1010 Modem Cable-Austria ▶ #1011 Modem Cable-Belgium ▶ #1012 Modem Cable-Africa ▶ #1013 Modem Cable-Israel ▶ #1014 Modem Cable-Italy ▶ #1015 Modem Cable-France ▶ #1016 Modem Cable-Germany ▶ #1017 Modem Cable-United Kingdom ▶ #1018 Modem Cable-Iceland/Sweden ▶ #1021 Modem Cable-Finland/Norway ▶ #1022 Modem Cable-Netherlands ▶ #1023 Modem Cable-Swiss ▶ #1024 Modem Cable-Denmark ▶ #1025 Modem Cable-U.S./Canada <p>Select one of the following cables to attach to port 1 (RVX port):</p> <ul style="list-style-type: none"> ▶ #0348 V.24/EIA232 20-ft (6 m) PCI cable ▶ #0349 V.24/EIA232 50-ft (15 m) PCI cable ▶ #0353 V.35 20-ft PCI cable ▶ #0354 V.35 50-ft PCI cable ▶ #0355 V.35 80-ft/24m PCI cable ▶ #0356 V.36 20-ft PCI cable ▶ #0358 V.36 150-ft/45m PCI cable ▶ #0359 X.21 20-ft PCI cable ▶ #0360 X.21 50-ft PCI cable ▶ #0365 V.24/EIA232 80-ft PCI cable ▶ #0367 Operations Console PCI Cable <p>The #0367 cable ships with a 25 pin to 9 pin adapter.</p> <p>When #0140 logical partitioning is specified, multiple #0367 cables can be ordered to connect the operations console in each partition.</p> <p>ECS is supported from the RVX port and one of the following cables is required to support ECS: #0348, #0349, or #0365. ECS is supported from the modem port with OS/400 V5R1 or later.</p> <p>#2793 2-Line WAN IOA with Modem</p> <p>The #2793 does not support the remote ring indicate function.</p> <p>For further configuration information, see: http://www.iseries.ibm.com/tstudio/planning/esa/esa.htm</p> <p>See the "Soft rules: iSeries IOA requirements" topic in <i>PCI and PCI-X Placement Rules for IBM System i5, eServer i5, and iSeries servers with i5/OS V5R4 and V5R3</i>, REDP-4011, or <i>PCI Card Placement Rules for the IBM @server iSeries Server OS/400 Version 5 Release 2: September 2003</i>, REDP-3638 for OS/400 V5R2 and earlier releases, for additional restrictions.</p> <p>Minimum operating system level: OS/400 V5R2 Supported on Models 270, 520, 550, 570, 595, 800, 810, 820, 825, 830, 840, 870, 890, SB2, SB3, and 9411-100. The #2793 is a Customer Install Feature.</p>
--	---

<p>#2794 #9794</p>	<p>#2794 2-Line WAN IOA with Modem</p> <p>The #2794/#9794 is a 2-line WAN with modem adapter and is the CIM version that is offered only in Australia and New Zealand. Port 0 is the modem port and supports V.92 56K Async PPP, V.92 data modem, V.44 data compression, and V.34 Fax modem and Fax functions such as ECM and 2D/1D conversion. Port 0 does not provide sync modem capabilities (SDLC and Sync PPP). Port 1 is the RVX port and supports multiple communications protocols.</p> <p>The #2794 can be directly attached to a Linux partition. When ordered as #0615 - Direct Attach #2794 PCI 2-Line WAN w/Modem, an IOP is not required. When directly attached to a Linux partition, the #2794 cannot be accessed by OS/400 partitions.</p> <p>Select one of the following cables to attach to port 0 (modem port):</p> <ul style="list-style-type: none"> ▶ #1019 Modem Cable-Australia ▶ #1020 Modem Cable-China (Hong Kong S.A.R.)/New Zealand <p>Select one of the following cables to attach to port 1 (RVX port): #0348, #0349, #0353, #0354, #0356, #0359, #0360, #0365 or #0367. Select one of the following cables to attach to port 1 (RVX port):</p> <ul style="list-style-type: none"> ▶ #0348 V.24/EIA232 20-ft (6 m) PCI cable ▶ #0349 V.24/EIA232 50-ft (15 m) PCI cable ▶ #0353 V.35 20-ft PCI cable ▶ #0354 V.35 50-ft PCI cable ▶ #0355 V.35 80-ft/24m PCI cable ▶ #0356 V.36 20-ft PCI cable ▶ #0358 V.36 150-ft/45m PCI cable ▶ #0359 X.21 20-ft PCI cable ▶ #0360 X.21 50-ft PCI cable ▶ #0365 V.24/EIA232 80-ft PCI cable ▶ #0367 Operations Console PCI Cable <p>The #0367 cable ships with a 25 pin to 9 pin adapter.</p> <p>When #0140 logical partitioning is specified, multiple #0367 cables can be ordered to connect the operations console in each partition.</p> <p>ECS is supported from the RVX port and one of the following cables is required to support ECS; #0348, #0349 or #0365. ECS is supported from the modem port with OS/400 V5R1 or later.</p> <p>The #2794 does not support the remote ring indicate function.</p> <p>For further configuration information, see: http://www.iseries.ibm.com/tstudio/planning/esa/esa.htm</p> <p>See the "Soft rules: iSeries IOA requirements" topic in <i>PCI and PCI-X Placement Rules for IBM System i5, eServer i5, and iSeries servers with i5/OS V5R4 and V5R3</i>, REDP-4011, or <i>PCI Card Placement Rules for the IBM @server iSeries Server OS/400 Version 5 Release 2: September 2003</i>, REDP-3638 for OS/400 V5R2 and earlier releases, for additional restrictions.</p> <p>Minimum operating system level: OS/400 V5R2 Supported on Models 270, 520, 550, 570, 595, 800, 810, 820, 825, 830, 840, 870, 890, SB2, SB3, and 9411-100. The #2794 is a Customer Install Feature.</p>
------------------------	---

#2805	<p>#2805 PCI Quad Modem IOA</p> <p>The #2805 is a 4-line WAN adapter with four WAN ports with internal modems. Connection to the ports is via telephone cable (RJ-11). This is the non-CIM version of the IOA.</p> <p>Supported protocols are:</p> <ul style="list-style-type: none"> ▶ V.92 56K Async PPP ▶ Fax applications at data rates up to 33.6K <p>The V.92 functions offer increased upload throughput, improved V.44 data compression, and shortened modem synchronization periods.</p> <p>The #2805 can be directly attached to a Linux partition. When ordered as #0616 - Direct Attach #2805 PCI Quad Modem IOA, an IOP is not required. When directly attached to a Linux partition, the #2805 cannot be accessed by OS/400 partitions.</p> <p>Country- or region-specific telephone cables must be ordered. A minimum of one modem cable and a maximum of four must be selected for each #2805. All modem cables on a system must be the same feature number.</p> <p>The supported modem cables are:</p> <ul style="list-style-type: none"> ▶ #1010 Modem Cable-Austria ▶ #1011 Modem Cable-Belgium ▶ #1012 Modem Cable-Africa ▶ #1013 Modem Cable-Israel ▶ #1014 Modem Cable-Italy ▶ #1015 Modem Cable-France ▶ #1016 Modem Cable-Germany ▶ #1017 Modem Cable-United Kingdom ▶ #1018 Modem Cable-Iceland/ Sweden ▶ #1021 Modem Cable-Fin/ Nor ▶ #1022 Modem Cable-Netherlands ▶ #1023 Modem Cable-Swiss ▶ #1024 Modem Cable-Denmark ▶ #1025 Modem Cable-U.S./Canada <p>The feature is country-specific or region-specific. Contact your IBM representative or Business Partner for details on availability.</p> <p>Restrictions:</p> <ul style="list-style-type: none"> ▶ The call waiting and modem on hold functions associated with V.92 are not supported. ▶ Remote Power On via ring-indicator, SDLC, and synchronous PPP are not supported. <p>One PCI card slot is required.</p> <p>Minimum operating system level: OS/400 V5R1 with PTFs identified in Information APAR II30079 at: http://www-912.ibm.com/supporthome.nsf/document/10000035</p> <p>Supported on Models 270, 520, 550, 570, 595, 800, 810, 820, 825, 830, 840, 870, 890, and 9411-100.</p> <p>The #2805 is a Customer Install Feature.</p>
#2806	<p>#2806 PCI Quad Modem (CIM)</p> <p>The #2806 is a 4-line WAN adapter with four WAN ports with internal modems. Connection to the ports is via telephone cable (RJ-11). This is the CIM version of the IOA. Supported protocols are:</p> <ul style="list-style-type: none"> ▶ V.92 56K Async PPP ▶ Fax applications at data rates up to 33.6K <p>The V.92 functions offer increased upload throughput, improved V.44 data compression, and shortened modem synchronization periods.</p> <p>The #2806 can be directly attached to a Linux partition. When ordered as #0617 - Direct Attach #2806 PCI Quad Modem (CIM), an IOP is not required. When directly attached to a Linux partition, the #2806 cannot be accessed by OS/400 partitions.</p> <p>Country- or region-specific telephone cables must be ordered. A minimum of one modem cable and a maximum of two must be selected for each #2806. All modem cables on a system must be the same feature number.</p> <p>The supported modem cables are:</p> <ul style="list-style-type: none"> ▶ #1019 Modem Cable- Australia ▶ #1020 Modem Cable- China (Hong Kong S.A.R.)/New Zealand <p>The #2806 is country-specific or region-specific. Contact your IBM representative or Business Partner for details on availability.</p>

#2806 (cont.)	<p>#2806 PCI Quad Modem (CIM) Restrictions:</p> <ul style="list-style-type: none"> ▶ The call waiting and modem on hold functions associated with V.92 are not supported. ▶ Remote Power On via ring-indicator, SDLC, and synchronous PPP are not supported. <p>One PCI card slot is required.</p> <p>Minimum operating system level: OS/400 V5R1 with PTFs identified in Information APAR II13079 at: http://www-912.ibm.com/supporthome.nsf/document/10000035 Supported on Models 270, 520, 550, 570, 595, 800, 810, 820, 825, 830, 840, 870, 890, SB2, SB3, and 9411-100. The #2806 is a Customer Install Feature.</p>
#2817	<p>#2817 PCI 155 Mbps MMF ATM IOA The #2817 is a 155 Mbps Asynchronous Transfer Mode (ATM) PCI card that allows the server to be attached to an ATM network using the Multi-Mode Fiber (MMF) 62.5 micron interface. This interface is intended for connection to both local area switches and direct connection to service provider equipment. The #2817 is typically used where 155 Mbps speeds are required over distances of less than 2 km.</p> <p>The #2817 is capable of supporting both multiple emulated LAN environments and enhanced TCP/IP performance with OS/400 V5R1. The #2817 is a 64-bit card, but is allowed to plug into any 32-bit or 64-bit slot. Feature maximums can be limited when used in combination with other LAN/ATM IOPs. One PCI card slot is required.</p> <p>Minimum operating system level: OS/400 V5R1; not supported with i5/OS V5R3 Supported on Models 810, 820, 825, 830, 840, 870, and 890. The #2817 is a Customer Install Feature.</p>
#2849 #9749	<p>#2849 10/100 Mbps Ethernet Adapter The #2849 10/100 Mbps Ethernet Adapter allows an iSeries server to attach to standardized 100 Mbps high-speed Ethernet LANs and allows attachment to existing 10 Mbps Ethernet LANs. The adapter comes standard with an RJ45 connector for attachment to UTP-5 media. Cabling for 10 Mbps must be CAT-3 or CAT-5, cabling for 100 Mbps must be CAT-5 that meets or exceeds Industry Standard EIA/TIA T568A or T568B. Maximum cable length is 100m.</p> <p>The #9749 Base PCI 100/10 Ethernet IOA is an optional feature available on new Model 800 and 810 systems, or as part of an upgrade order from a Model 270, 720, 730, or 820 to a Model 810. If the client does not select the feature on the initial order, they are not entitled to receive the feature in the future.</p> <p>The #2849 can be directly attached to a Linux partition. When ordered as #0623 - Direct Attach #2849 PCI 100/10 Mbps Ethernet IOA, an IOP is not required. When directly attached to a Linux partition, the #2849 cannot be accessed by OS/400 partitions.</p> <p>Supports LAN console The #2849 is not supported on any Integrated Netfinity Server or Integrated xSeries Server.</p> <p>Minimum operating system level: OS/400 V5R2 Supported on Models 270, 520, 550, 570, 595, 800, 810, 820, 825, 830, 840, 870, 890, SB2, SB3, and 9411-100. The #2849 is a Customer Install Feature. The #9749 is withdrawn from marketing as of 01 October 2005. The #2849 is withdrawn from marketing as of 01 June 2006. A #5700 PCI 1 Gbps Ethernet IOA is the recommended replacement.</p>
#4723	<p>#4723 PCI 10 Mbps Ethernet Adapter The #4723 PCI Ethernet IOA provides single attachment to one Carrier Sense Multiple Access/Collision Detect Local Area Network. The feature consists of an adapter card and internal code which supplies Ethernet version 2 and IEEE 802.3 MAC plus IEEE 802.2 LLC functions. The Ethernet/IEEE 802.3 IOA is capable of operating in half or full duplex mode. The #4723 has an RJ45 connector and a 15 pin D-Shell connector for attachment to client-supplied cabling. A vendor AUI Ethernet cable or RJ45 twisted pair cable must be ordered separately. The #4723 is not supported by the #2790 PCI Integrated Netfinity Server or the #2791/#2799 PCI Integrated xSeries Server.</p> <p>Minimum operating system level: OS/400 V4R5 Supported on Models 270, 9406 520, 550, 570, 595, 810, 820, 825, 830, 840, 870, 890, SB2, SB3, and 9411-100. The #4723 is a Customer Install Feature.</p>

#4745	<p>#4745 PCI 2-line WAN IOA</p> <p>The #4745 supports up to two multiple protocol communications ports when one or two of the following cables are attached:</p> <ul style="list-style-type: none"> ▶ #0348 V.24/EIA232 20-ft (6 m) PCI cable ▶ #0349 V.24/EIA232 50-ft (15 m) PCI cable ▶ #0353 V.35 20-ft PCI cable ▶ #0354 V.35 50-ft PCI cable ▶ #0355 V.35 80-ft PCI cable ▶ #0356 V.36 20-ft PCI cable ▶ #0358 V.36 150-ft PCI cable ▶ #0359 X.21 20-ft PCI cable ▶ #0360 X.21 50-ft PCI cable ▶ #0365 V.24/EIA232 80-ft PCI cable ▶ #0367 Operations Console PCI Cable <p>The #4745 can be directly attached to a Linux partition. When ordered as #0608 - Direct Attach #4745 PCI WAN IOA, an IOP is not required. When directly attached to a Linux partition, the #4745 cannot be accessed by OS/400 partitions.</p> <p>When #0140 Logical Partitioning Specify is ordered, multiple #0367 cables can be ordered to connect the operations console in each partition. One #0367 cable per #4745.</p> <p>When the #4745 is selected to support ECS, one of the following cables must be specified:</p> <ul style="list-style-type: none"> ▶ #0348 V.24/EIA232 20-ft (6 m) PCI cable (Default) ▶ #0349 V.24/EIA232 50-ft (15 m) PCI cable ▶ #0365 V.24/EIA232 80-ft PCI cable <p>Minimum operating system level: OS/400 V4R5 Supported on Models 270, 9406 520, 550, 570, 595, 810, 820, 825, 830, 840, 870, 890, SB2, SB3, and 9411-100. The #4745 is a Customer Install Feature. The #4745 is withdrawn from marketing as of 01 June 2006.</p>
#4750	<p>#4750 PCI ISDN BRI U IOA</p> <p>The #4750 is a four-port (8 channel) ISDN BRI (basic rate) full sized PCI card. Each port consists of 2B+D configuration. The #4750 is the "U"-bus (2 wire) version of the ISDN BRI PCI card. The #4750 supports the following protocols:</p> <ul style="list-style-type: none"> ▶ PPP (communicates with remote analog modems (V.90) as well as with remote ISDN devices) ▶ IDLC ▶ Fax <p>Four 30-ft (9.3 m) RJ-45 to RJ-45 network cables are shipped with each #4750. For configuration purposes, each #4750 counts as eight lines (two lines per port) toward the system communication maximums. Supports full duplex. The #4750 requires country (region) certification or homologation. A full sized PCI card slot is required. Maximum: One per IOP</p> <p>Minimum operating system level: OS/400 V4R5; OS/400 V5R1 is the last release to support the #4750. Supported in Models 820, 830, 840, 890, #5075, #0578, #5078, #5074, #5079, #8079, #8093/5097, #9074, and #9079. The #4750 is a Customer Install Feature.</p>

#4751	<p>#4751 PCI ISDN BRI S/T IOA</p> <p>The #4751 is a four-port (eight channel) ISDN BRI (basic rate) full sized PCI card. Each port consists of 2B+D configuration. The #4751 is the "S/T"-bus (four wire) version of the #4750 PCI ISDN BRI U IOA.</p> <p>The #4751 requires a network terminating device in the circuit. In the United States and Canada, this must be provided by the client. In other countries or regions, it is most likely provided by the telephone company.</p> <p>The #4751 supports the following protocols:</p> <ul style="list-style-type: none"> ▶ PPP (communicates with remote analog modems (V.90) as well as with remote ISDN devices) ▶ IDLC ▶ Fax <p>Four 30-ft (9.3 m) RJ-45 to RJ-45 network cables are shipped with each #4751. For configuration purposes, each #4751 counts as eight lines (two lines per port) towards the system communication maximums. Supports full duplex.</p> <p>Maximum: One per IOP.</p> <p>The #4751 requires country or region certification or homologation.</p> <p>A full sized PCI card slot is required.</p> <p>Minimum operating system level: OS/400 V4R5; OS/400 V5R1 is the last release to support the #4751.</p> <p>Supported in Models 270, 820, 830, 840, #5075, #0578, #5074, #5078, #5079, #8079, #8093/#5097, #9074, and #9079.</p> <p>The #4751 is a Customer Install Feature.</p>
#4761	<p>#4761 PCI Integrated Analog Modem</p> <p>The #4761 is based on the latest Digital Signal Processor (DSP) technology. The #4761 allows the modem function to be integrated into the IOA and supports multiple analog modem ports (eight phone lines). The #4761 supports the following protocols without the need for an external modem:</p> <ul style="list-style-type: none"> ▶ SLIP/PPP (uses V.90, so the maximum line speed is 56 Kbps) ▶ SDLC (uses V.34, so the maximum line speed is 33.6 Kbps) ▶ Fax (uses V.17 to achieve a 14.4 Kbps maximum line speed) <p>OS/400 V5R1 is the last release to support non-Fax functions on the #4761. An ASYNC line description is required for Fax and can only be used for Fax. The ECS line is not supported. To the iSeries or AS/400e server, the #4761 appears like a single IOA with eight individual line resources available. Eight 30-ft (8 m) phone cables are shipped with each #4761. For configuration purposes, each #4761 counts as eight communications lines toward the system communication maximums. Supports full duplex.</p> <p>The #4761 requires country or region certification or homologation.</p> <p>A full sized PCI card slot is required.</p> <p>Minimum operating system level: OS/400 V4R5; not supported with i5/OS V5R3</p> <p>Supported in Models 820, 830, 840, #5075, #0578, #5078, #5074, #5079, #8079, #8093/#5097, #9074, and #9079.</p> <p>The #4761 is a Customer Install Feature.</p>
#4801	<p>#4801 PCI Cryptographic Coprocessor</p> <p>The #4801 is a hardware cryptography solution. The #4801 is a half-length PC form-factor PCI card that offers rich cryptography function, secure storage of cryptographic keys, and 12 MBps performance (at the card level) for bulk data encryption and triple DES capability. The #4801 is available worldwide. The level of cryptographic function is determined by the Cryptographic Access Provider licensed program that is downloaded to the adapter.</p> <p>If your application requires a FIPS 140-1 certified, tamper-resistant module for storing cryptographic keys, financial PIN processing, or both, then the #4801 PCI Cryptographic Coprocessor should be your choice. Federal Information Processing Standard (FIPS) 140-1 is a U.S. Government National Institute of Standards and Technology (NIST) administered standard and certification program for cryptographic modules.</p> <p>Due to temperature requirements (card temperature must not drop below 5 degrees F (-15 degrees C)), the #4801 is shipped separately from the system in special packing.</p> <p>Minimum operating system level: OS/400 V4R5</p> <p>Supported on Models 250, 270, 520, 550, 570, 595, 800, 810, 820, 825, 830, 840, 870, 890, SB2, SB3, and 9411-100.</p> <p>The #4801 is a Customer Install Feature.</p> <p>The #4801 is withdrawn from marketing as of 1 June 2006. A #4806 PCI-X Cryptographic Coprocessor is the recommended replacement.</p>

#4805	<p>#4805 PCI Cryptographic Accelerator</p> <p>The #4805 provides improved performance for high transaction rate secure Web applications that use the Secure Sockets Layer (SSL) or Transport Layer Security (TLS) protocols. The process of using SSL/TLS secure Web connections, is compute intensive. The Cryptographic Accelerator can be used to off-load cryptographic processing from main CPU. SSL/TLS secure Web connections are used to protect information (for example, credit card number) as it is transferred over the Internet, such as between a Web browser and a server.</p> <p>The Cryptographic Accelerator is targeted to high transaction rate secure Web applications using SSL/TLS.</p> <p>There is a maximum of two per IOP.</p> <p>The #4805 requires an available PCI card slot under a feature IOP, not under a base or embedded IOP in the system unit.</p> <p>Minimum operating system level: OS/400 V5R2 Supported on Models 270, 520, 550, 570, 595, 800, 810, 820, 825, 830, 840, 870, 890, SB2, SB3, and 9411-100. The #4805 is a Customer Install Feature. The #4805 is withdrawn from marketing as of 01 June 2006.</p>
#4806	<p>#4806 PCI-X Cryptographic Coprocessor</p> <p>The #4806 PCI-X Cryptographic Coprocessor provides both cryptographic coprocessors and secure-key cryptographic accelerator functions in a single PCI-X card. The coprocessor functions are targeted to banking and finance applications. Financial PIN processing and Europay, Master Card, Visa (EMV) credit card functions are provided. EMV is a standard for integrated-chip based credit cards. The secure-key accelerator functions are targeted to improving the performance of i5/OS Secure Sockets Layer (SSL) transactions. The #4806 provides the security and performance required to support e-business and emerging digital signature applications.</p> <p>The #4806 provides secure storage of cryptographic keys in a tamper-resistant hardware security module (HSM), which is designed to meet FIPS 140 security requirements. FIPS 140 is a U.S. Government National Institute of Standards & Technology (NIST) administered standard and certification program for cryptographic modules.</p> <p>The firmware for the #4806 is available on a separately ordered/distributed CD. This firmware is an LPO product: 5733-CY1 Cryptographic Device Manager. The #4806 also requires licensed program 5722-AC3 Cryptographic Access Provider to enable data encryption.</p> <p>Supported on Models 520, 550, 570, 595, 9411-100. This feature has country-specific usage. Refer to your IBM representative in your country for availability or restrictions.</p>

#4811 #4812 #4813 #9812 #9813	<p>#4811/#4812/#4813/#9812/#9813 PCI-X Integrated xSeries Server</p> <p>The #4811/#4812/#4813/#9812/#9813 PCI-X Integrated xSeries Server contains a 2.0 GHz processor with 2 MB integrated L2 cache.</p> <p>The #4811 is supported in the 520 system tower.</p> <p>The #4812 is supported in the 550, 595, 800, 810, 825, 870 and 890 system towers and in the #0588, #0595, #5088, #5095, #5074, #5079, #5094 and #5294 expansion towers.</p> <p>The #4813 is supported in the 570 system tower and in the #5790 PCI Expansion Drawer.</p> <p>The #9812 and #9813 are functionally identical to #4812 and #4813 but are included in the base with orders for Enterprise Editions on Models 550, 595 and 570.</p> <p>The #4811/#4812/#4813/#9812/#9813 PCI-X Integrated xSeries Server has two memory slots and supports up to 2 GB of memory. Both slots must always contain a pair of identical memory features. When #4811/#4812/#4813/#9812/#9813 is ordered, the configurator adds two #9726 base 512 MB server memory features to the order. The two #9726 features can be replaced with two #8546 optional base 1 GB server memory features.</p> <p>The following main storage cards provide memory for the #4811/#4812/#4813/#9812/#9813 PCI-X Integrated xSeries Server:</p> <ul style="list-style-type: none"> ▶ #9726 - Base 512 MB Server Memory (Initial order only) ▶ #8546 - Opt Base 1 GB Server Memory (Initial order only) ▶ #0446 - 512 MB DDR Server Memory (Upgrade only) ▶ #0447 - 1 GB DDR Server Memory (Upgrade only) <p>The #4811/#4812/#4813/#9812/#9813 PCI-X Integrated xSeries Server occupies two PCI slots and requires an IOP #9744, #9844 or #2844 to drive it. The configurator adds no charge feature #9744 Base PCI IOP to the order. However the #9744 can be removed from the order for PCI slot conservation. The IOP can be shared with other IOAs, but only one #4811/#4812/#4813/#9812/#9813 is permitted per IOP.</p> <p>Placement of the #4811 is limited to slot P1-C4 on the Model 520 system unit. The #4811 hangs over slot P1-C5 and occupies two PCI slots. The #4811 Integrated xSeries Server is mutually exclusive with #6594 - 4-Disk Slot Expansion, as the #6594 repositions the SCSI cable connector so that a long card can be placed in card slot 4 and forces card slot 5 to be a short card. Therefore, you cannot have #4811 PCI Integrated xSeries Server in the 520 system unit if you also have a #6594.</p> <p>Placement of the #4812/#9812 is limited to specific PCI slots within the 550, 595, 800, 810, 825, 870 and 890 system towers and in the various expansion towers. Placement of the #4813/#9813 is limited to specific PCI slots within the 570 system unit and #5790 PCI Expansion Drawer.</p> <p>The #4811/#4812/#4813/#9812/#9813 PCI-X Integrated xSeries Server includes two embedded 1000/100/10 Mbps UTP Ethernet LAN ports for attachment to IEEE standard 802.3Z high-speed (1 Gbps) Ethernet LANs. The Ethernet LAN ports can also be used to connect to existing 10 and 100 Mbps Ethernet LANs. The adapter supports UTP CAT 5 or higher media interface and TCP/IP.</p> <p>The #4811/#4812/#4813/#9812/#9813 PCI-X Integrated xSeries Server ships with a standard keyboard/mouse splitter cable and supports either a standard or USB 1.1 keyboard or mouse. An SVGA video port is included to connect a display.</p> <p>The #4811/#4812/#4813/#9812/#9813 PCI-X Integrated xSeries Server runs Windows or Linux.</p> <ul style="list-style-type: none"> ▶ The supported versions of Windows are: <ul style="list-style-type: none"> – Windows 2000 Server and 2000 Advanced Server – Windows Server 2003 Standard, Enterprise and Web Edition ▶ The supported versions of Linux are: <ul style="list-style-type: none"> – Red Hat Enterprise Linux ES 3 – Red Hat Enterprise Linux AS 3 <p>For the latest information about Windows on iSeries and eServer i5, see: http://www.ibm.com/eserver/iserries/integratedxseries/</p> <p>For the latest information about Linux on Series and eServer i5, see: http://www.ibm.com/eserver/iserries/integratedxseries/linux</p> <p>The following rules apply when ordering the PCI-X Integrated xSeries Server:</p> <ul style="list-style-type: none"> ▶ #0325 IPCS Extension Cable for Windows is the default (but can be removed). ▶ #1700 IPCS Keyboard and Mouse for Windows is the default (in those countries or regions offering it). ▶ Requires a display and must be connected to the #4811/#4812/#4813/#9812/#9813 to support Windows 2000. ▶ A display is not required for Windows 3000. If no display is connected the Virtual system Console is used. <p>For a non-U.S. keyboard, mouse and display, see: http://www.ibm.com/eserver/iserries/integratedxseries/</p>
---	---

<p>#4811 #4812 #4813 #9812 #9813 (cont.)</p>	<p>#4811/#4812/#4813/9812/#9813 PCI-X Integrated xSeries Server For the latest on Linux on iSeries and eServer i5, see: http://www-1.ibm.com/servers/eserver/iseries/integratedxseries/linux/</p> <p>Restrictions:</p> <ul style="list-style-type: none"> ▶ Native OS/400 functions and external host LAN are not supported. ▶ TCP/IP only supported on the Ethernet LAN ports. ▶ Not supported in system tower of Model 820, 830, 840 or earlier. <p>Minimum operating system level: i5/OS V5R3 The #4811, #4812, #4813, #9812, and #9813 are Customer Install Features.</p>
#4815	<p>#4815 PCI ATM 155 Mbps UTP OC3 The #4815 is a 155 Mbps ATM PCI card that allows the iSeries or AS/400e server to be attached to an ATM network using the Unshielded Twisted Pair (UTP-5) interface. This interface is intended for connection to both local area switches and direct connection to service provider equipment. The #4815 is typically used where 155 Mbps speeds are required over distances of less than 100m. Technical specifications and industry standards supported are available at the ATM Forum Web site at: http://www.atmforum.com</p> <p>Minimum operating system level: OS/400 V4R5; not supported with i5/OS V5R3 Supported on Models 800, 810, 820, 825, 830, 840, 870, and 890. The #4815 is a Customer Install Feature.</p>
#4816	<p>#4816 PCI ATM 155 Mbps MMF The #4816 is a 155 Mbps ATM PCI card that allows the iSeries or AS/400e server to be attached into an ATM network using the MMF 62.5 micron interface. This interface is intended for connection to both local area switches and direct connection to service provider equipment. The #4816 is typically used where 155 Mbps speeds are required over distances of less than 2 km. Technical specifications and industry standards supported are available at the ATM Forum Web site at: http://www.atmforum.com</p> <p>The #4816 is orderable for use in OS/400 V4R5 secondary partitions. For OS/400 V5R1 systems or partitions, order the #2817 PCI 155 Mbps MMF ATM IOA.</p> <p>Minimum operating system level: OS/400 V4R5; not supported with i5/OS V5R3 Supported on Models 800, 810, 820, 825, 830, 840, 870, and 890. The #4816 is a Customer Install Feature.</p>
#4818	<p>#4818 PCI ATM 155 Mbps SMF OC3 The #4818 is a 155 Mbps ATM PCI card that allows the iSeries or AS/400e server to be attached to an ATM network using the Single-Mode Fiber (SMF) 9 micron interface. This interface is intended primarily for direct connection to service provider equipment. The #4818 is typically used where 155 Mbps speeds are required over distances of from 16 to 40 km. Technical specifications and industry standards supported are available at the ATM Forum Web site at: http://www.atmforum.com</p> <p>Minimum operating system level: OS/400 V4R5; not supported with i5/OS V5R3 Supported on Models 800, 810, 820, 825, 830, 840, 870, and 890. The #4818 is a Customer Install Feature.</p>
#4838	<p>#4838 PCI 100/10 Mbps Ethernet IOA The #4838 PCI 100/10 Mbps Ethernet IOA feature allows the iSeries or AS/400e server to attach to standardized 100 Mbps high-speed Ethernet LANs and allows attachment to existing 10 Mbps Ethernet LANs. The adapter comes standard with an RJ45 connector for attachment to UTP-5 media. Cabling for 10 Mbps must be CAT-3 or CAT-5, and cabling for 100 Mbps must be CAT-5 that meets or exceeds Industry Standard EIA/TIA T568A or T568B. The maximum cable length is 100m.</p> <p>This Ethernet IEEE 802.3 IOA is capable of operating in half or duplex mode. If the #4838 is selected to run on the #2790 PCI Integrated Netfinity Server or #2791/#2799 PCI Integrated xSeries Server, then specify code #0224 is required for each #4838 selected to run on the #2790/ #2791/#2799.</p> <p>The #4838 can be directly attached to a Linux partition. When ordered as #0607 - Direct Attach #4838 PCI 100/10 Mbps Ethernet IOA, an IOP is not required. When directly attached to a Linux partition, the #4838 cannot be accessed by OS/400 partitions.</p> <p>Supports LAN console. Minimum operating system level: OS/400 V4R5 Supported on Models 270, 9406 520, 550, 570, 595, 800, 810, 820, 825, 830, 840, 870, 890, and 9411-100. The #4838 is a Customer Install Feature. The #4838 is withdrawn from marketing as of 01 October 2004. A #2849 is the recommended replacement.</p>

#4960	<p>#4960 - Cryptographic Accelerator</p> <p>The IBM e-business Cryptographic Accelerator is a short form factor PCI SSL hardware accelerator adapter. For Secure Web transaction, SSL operations is a key requirement. To do this, public-key cryptographic operations using SSL handshake protocol is employed. The IBM e-business Cryptographic Accelerator is a hardware cryptographic solution that off-loads this compute-intensive public-key cryptographic processing from the host.</p> <p>Minimum operating system level: AIX 5L for POWER V5.2 Supported for conversion only. Supported on Models 570 and 595. The #4960 is a Customer Install Feature. The #4960 is withdrawn from marketing as of 01 December 2005.</p>
#5700	<p>#5700 PCI 1 Gbps Ethernet IOA</p> <p>The #5700 PCI 1 Gbps Ethernet IOA allows an iSeries server to attach to IEEE standard 802.3Z high-speed (1 Gbps) Ethernet LANs. It can also be used to connect to existing 10 Mbps or 100 Mbps Ethernet LANs by using switches with 10, 100, or 1000 Mbps ports. It cannot directly attach to 10 Mbps or 100 Mbps LANs. Crossover cables are not supported.</p> <p>The #5700 adapter supports a multimode fiber interface with a 62.5 micron or 50.0 micron cable requirement. The #5700 adapter has a duplex LC fiber optic connector for attachment to client-supplied cabling. The #5700 uses short wave technology (around 500m maximum). The 5700 supports auto-negotiation but only negotiates to the gigabit fiber standard of 1000/full.</p> <p>Supports TCP/IP protocol only; SNA and IPX connections not supported</p> <p>The #5700 PCI 1 Gbps Ethernet IOA can be run under a #2792 PCI Integrated xSeries Server or #2892 PCI Integrated xSeries Server. If a #5700 is controlled by a #2x92 Integrated xSeries Server, then #0226 1 Gbps Ethernet Specify must be ordered. Order one #0226 for each #5700 PCI 1 Gbps Ethernet IOA controlled by an Integrated xSeries Server.</p> <p>When the #5700 is not installed in an Integrated xSeries Server, there is a maximum of one #5700 per Multi-adapter Bridge Boundary. Combinations of #5700s controlled by Integrated xSeries Server-controlled and controlled by PCI IOPs are allowed within a Multi-adapter Bridge Boundary.</p> <p>The #5700 can be directly attached to a Linux or AIX partitions with SUSE Linux Enterprise Server 9 for POWER or Red Hat Enterprise Linux AS for POWER Version 3, and AIX 5L for POWER V5.2. When ordered as #0620 - Direct Attach #5700 PCI 1 Gbps Ethernet IOA, an IOP is not required. When directly attached to a Linux partition, the #5700 cannot be accessed by OS/400 partitions.</p> <p>PCI card slots required: One 32-bit slot in the Model 830, 840, SB2, or SB3 system units, or in the #0578, #5074, #0574, #5075, #5078, #5079, #8079, #8093-002, #9074, #9079 PCI Expansion Towers.</p> <p>There are exceptions for 32-bit slot placement in the Model 270 and 810 system units. See the system unit schematics in 3.8, "9406 Model 810 system unit schematic" on page 74, and <i>PCI and PCI-X Placement Rules for IBM System i5, eServer i5, and iSeries servers with i5/OS V5R4 and V5R3</i>, REDP-4011, or <i>PCI Card Placement Rules for the IBM @server iSeries Server OS/400 Version 5 Release 2: September 2003</i>, REDP-3638 for backplane layout, PCI slot positions, and allowable #5700 slot plugging rules by model.</p> <p>The following rules do not apply when the #5700 is controlled by a #2790/#2890 PCI Integrated Netfinity Server or by a #2791/#2891, #2792/#2892, #4710/#4810, or #2799/#2899 PCI Integrated xSeries Server.</p> <ul style="list-style-type: none"> ▶ Must be placed in a 64-bit slot in the Model 825, 870, 890 or in the #0588, #0595, #5094/#0694, #5088, #5095, #5294, #8094, and #9094 towers. ▶ Limit the quantity of one #5700 adapter per Multi-adapter Bridge boundary. ▶ Can be combined with a maximum of one other IOA on an IOP. <p>LAN console is not supported with OS/400 V5R2 or i5/OS V5R3. Minimum operating system level: OS/400 V5R2 with PTF MF33086 or i5/OS V5R3 MF33087. The #5700 is a Customer Install Feature.</p>

#5701	<p>#5701 PCI 1 Gbps Ethernet UTP IOA</p> <p>The #5701 PCI 1 Gbps Ethernet UTP IOA allows a System i server to attach to IEEE standard 802.3Z high-speed (1 Gbps) Ethernet LANs. The #5701 can directly connect to 10 Mbps or 100 Mbps Ethernet LANs, however, it does not run at gigabit speeds in this configuration. Crossover cables are not supported. The #5701 adapter supports a UTP CAT 5 media interface.</p> <p>A #5701 PCI 1 Gbps Ethernet UTP IOA can be run under a #2792 PCI Integrated xSeries Server or #2892 PCI Integrated xSeries Server. If a #5701 is controlled driven by a #27x2 Integrated xSeries Server, then #0226 1 Gbps Ethernet Specify must be ordered. Order one #0226 for each #5701 controlled by an Integrated xSeries Server. When the #5701 is not installed in an Integrated xSeries Server, there is a maximum of one #5701 per Multi-adapter Bridge Boundary. Combinations of Integrated xSeries Server controlled and PCI IOP controlled #5701s within an Multi-adapter Bridge Boundary are allowed.</p> <p>The #5701 supports auto-negotiation if configured as *Auto/*Auto for gigabit interfaces and negotiates to the highest capability of the link partner. This is usually 100/full or 1000/full. When the link partner is not capable of auto-negotiation then hard coded values can be entered (for example, 100/half, 1000/full). In this case, auto negotiation is turned off and the configured speed is used.</p> <p>The #5701 can be directly attached to a Linux partition. When ordered as #0621 - Direct Attach #5701 PCI 1 Gbps Ethernet UTP IOA, an IOP is not required. When directly attached to a Linux partition, the #5701 cannot be accessed by OS/400 partitions.</p> <p>Supports TCP/IP protocol only; SNA and IPX connections not supported.</p> <p>PCI card slots required: One 32-bit slot in the Model 830, 840, SB2, or SB3 system units, or in the #0578, #5074, #0574, #5075, #5078, #5079, #8079, #8093-002, #9074, #9079 PCI Expansion Towers</p> <p>The following rules do not apply when the #5701 is controlled by a #2790/#2890 PCI Integrated Netfinity Server or by a #2791/#2891, #2792/#2892, #4710/#4810, or #2799/#2899 PCI Integrated xSeries Server.</p> <ul style="list-style-type: none"> ▶ Must be placed in a 64-bit slot in the Model 825, 870, 890 or in the #0588, #0595, #5094/#0694, #5088, #5095, #5294, #8094, and #9094 towers. ▶ Limit the quantity of one #5701 adapter per Multi-adapter Bridge boundary. ▶ Can be combined with a maximum of one other IOA on an IOP. <p>Does not support LAN console OS/400 V5R2 or i5/OS V5R3. Minimum operating system level: OS/400 V5R2 with PTF MF33086 or i5/OS V5R3 MF33087. The #5701 is a Customer Install Feature.</p>
-------	--

#5706	<p>#5706 PCI-X 1 Gbps Ethernet-TX IOA</p> <p>The #5706 PCI-X 1 Gbps Ethernet-TX IOA is a 2-port 1000/100/10 Mbps Base-TX Ethernet PCI-X Adapter. The #5706 is a full duplex, dual ported, Gigabit Ethernet adapter designed with highly integrated components. The #5706 adapter can be configured to run each port at 1000, 100, or 10 Mbps data rates. The #5706 interfaces to the system via a PCI or PCI-X bus and connects to a network using a 4-pair CAT-5 Unshielded Twisted Pair (UTP) cable for distances of up to 100m. The #5706 adapter conforms to the IEEE 802.3ab 1000 Base-T standard. Jumbo frames are supported when running at the 1000 Mbps speed.</p> <p>The #5706 can be directly attached to a Linux or AIX partition as supported with SUSE Linux Enterprise Server 9 for POWER or Red Hat Enterprise Linux AS for POWER Version 3, and AIX 5L for POWER V5.2. When ordered as #0643 - Direct Attach #5706 PCI-X Gbps Ethernet-TX IOA an IOP is not required. When directly attached to a Linux/AIX partition, the #5706 cannot be accessed by OS/400 partitions.</p> <p>The #5706 does not require (is not supported by) a PCI IOP, even in an OS/400 partition. For optimum performance, place the adapter in a 64 bit PCI-X card slot.</p> <p>Restrictions:</p> <ul style="list-style-type: none"> ▶ Does not support SNA. ▶ Does not support LAN console i5/OS V5R3. With i5/OS V5R4 can be used as Lan Console is used for console one port is dedicated to console function. ▶ The 1000 Mbps speed is not supported in Half Duplex (HDX) mode. <p>The following functions are supported by AIX, but are not supported by i5/OS with the #5706 PCI-X 1 Gbps Ethernet-TX IOA:</p> <ul style="list-style-type: none"> ▶ <i>Large Send</i>, sometimes known as <i>TCP Segmentation</i>, offloads the TCP segmentation operation from the IP layer to the adapter for outgoing (transmit side) TCP segments. ▶ <i>Checksum Off load</i> offloads the TCP/UDP Checksum Operation or workload from the CPU to the adapter. Checksum Offload is supported by Linux with the 2.6 kernel, for example SLES9xx. <p>Minimum operating system level: i5/OS V5R3 with PTF MF33087 Supported on Models 520, 550, 570, and 595. The #5706 is a Customer Install Feature.</p>
#5707	<p>#5707 PCI-X 1 Gbps Ethernet-SX IOA</p> <p>The #5707 PCI-X 1 Gbps Ethernet-SX IOA is a 2-port Gigabit Ethernet-SX PCI-X Adapter that provides two 1 Gbps (1000 Base-SX) full-duplex Ethernet LAN connections with throughput on a standard shortwave multimode optical cable that conforms to the IEEE 802.3z standard. The adapter supports distances of 260m for 62.5 micron Multi Mode Fiber (MMF) and 550m for 50.0 micron MMF. Jumbo frames are supported when running at the 1000 Mbps speed.</p> <p>The #5707 PCI-X 1 Gbps Ethernet-SX IOA supports Large Send (sometimes known as TCP Segmentation). This function offloads the TCP segmentation operation from the IP layer to the adapter for outgoing (transmit side) TCP segments. The #5707 also supports Checksum Offload, which offloads the TCP/UDP Checksum Operation or workload from the CPU to the adapter.</p> <p>The #5707 does not require (is not supported by) a PCI IOP, even in an i5/OS partition. For optimum performance, the adapter should be placed in a 64 bit PCI-X card slot whenever possible. The 2-port IBM Gigabit Ethernet-SX PCI-X Adapter incorporates an LC type connector on the card.</p> <p>Restrictions:</p> <ul style="list-style-type: none"> ▶ Does not support SNA. ▶ Does not support LAN console i5/OS V5R3. ▶ Half duplex (HDX) mode is not supported. <p>The following functions are supported by AIX, but are not supported by i5/OS with the #5706 PCI-X 1 Gbps Ethernet-TX IOA:</p> <ul style="list-style-type: none"> ▶ <i>Large Send</i>, sometimes known as <i>TCP Segmentation</i>, offloads the TCP segmentation operation from the IP layer to the adapter for outgoing (transmit side) TCP segments. ▶ <i>Checksum Off load</i> offloads the TCP/UDP Checksum Operation or workload from the CPU to the adapter. Checksum Offload is supported by Linux with the 2.6 kernel, for example SLES9xx. <p>Minimum operating system level: i5/OS V5R3 with MF33087. Supported on Models 520, 550, 570, and 595. The #5707 is a Customer Install Feature.</p>

#5719	<p>10 Gbps Ethernet IOA (Long) 10 Gigabit Ethernet PCI-X-based server which provides connections over a maximum of 10km of 1310nm single-mode fiber optic cable. The adapter conforms to the IEEE 802.3ae standard. The adapter requires 9um single-mode fiber optic cables and uses an SC connector type for connecting into network infrastructure components like 10 Gigabit Ethernet switch/router with SC connectors.</p> <p>Minimum operating system level: AIX 5L for Power, OS/400 V5R2 Supported on Models 520, 550, 570 and 595.</p>
#5740	<p>#5740 1Gbps BaseT Ethernet (4-port) The #5740 provides a 4-port 10/100/1000 Mbps Base Ethernet adapter which supports four 1-Gigabit ports on a single adapter, delivering increased bandwidth for slot-constrained servers and providing high connectivity and reliability using two integrated, dual-port Gigabit Ethernet controllers.</p> <p>Characteristics include:</p> <ul style="list-style-type: none"> ▶ Supports 64-bit Bus Mastering on the PCI-X bus ▶ Compliant with IEEE 802.3ab 1000Base-T, 803.u 100Base-TX, 802.3 10Base-T standards and supports 802.1q VLAN tagging ▶ Supports interrupt moderation ▶ TCP Segmentation off-load and encapsulation in hardware ▶ Checksum off-loading of IP, TCP, and UDP frame ▶ Remote Management Support ▶ Delivers increased connectivity while significantly reducing CPU Utilization ▶ Provides 10/100/1000 Mbps connectivity through four RJ-45 ports using CAT-5 cables ▶ Support for Boot ROM on two ports ▶ Supports advanced cable diagnostics <p>Minimum operating system level: AIX 5L for POWER V5.2 for IBM eServer, Red Hat Enterprise Linux AS for POWER Version 4, SUSE Linux Enterprise Server 9 for POWER Supported on Models 520+, 550+, 570+, 595 1.9 GHz, 520, 550, 570, and 595.</p>
#6800	<p>#6800 PCI 1Gbps Ethernet IOA The #6800 - PCI 1 Gbps Ethernet IOA provides a PCI-X IOA which does not require an IOP and allows a system to attach to IEEE standard 802.3Z high speed (1 Gbps) Ethernet LANs. The #6800 adapter supports a multimode fiber interface with a 62.5 micron or 50.0 micron cable requirement. The adapter has a duplex LC fiber-optic connector for attachment to customer-supplied cabling.</p> <p>The #6800 only supports TCP/IP and requires an intervening switch/hub/router when connected to 100 Mbps or 10 Mbps networks.</p> <p>The #6800, #0620, and #5700 are physically the same adapter card but have different feature numbers that denote to IBM configurator tools whether or not an IOP is required. See the description of the “#5700” on page 208 for information about the function provided by the #6800.</p> <p>Minimum operating system level: i5/OS V5R4 Supported on Models 520+, 550+, 570+, 595 1.9 GHz, 520, 550, 570, and 595.</p>
#6801	<p>#6801 PCI 1Gbps Ethernet UTP IOA The #6801 - PCI 1 Gbps Ethernet UTP IOA provides a PCI-X IOA which does not require an IOP and allows a system to attach to IEEE standard 802.3ab high speed (1 Gbps) Ethernet LANs. It can also be used to directly connect to existing 10 Mbps or 100 Mbps Ethernet LANs, however, it does not run at gigabit speeds in this configuration. Crossover cables are not supported. The adapter supports a UTP CAT 5 media interface and has a RJ-45 connector.</p> <p>The #6801, #0621, and #5701 are physically the same adapter card but have different feature numbers that denote to IBM configurator tools whether or not an IOP is required. See , “#5701” on page 209 for more information about the function provided by the #6801.</p> <p>Minimum operating system level: i5/OS V5R4 Supported on Models 520+, 550+, 570+, 595 1.9 GHz, 520, 550, 570, and 595.</p>

#6803 #9493	<p>#6803 PCI WAN for ECS</p> <p>The #6803 is a WAN w/modem adapter which provides connectivity for IBM Electronic Customer Support (ECS) only. This feature is the non-CIM (Complex Impedance Matching) version offered in all countries except Australia and New Zealand. The #6803 is functionally equivalent to #0614/#2793/#9793, but #6803 indicates to IBM configurator tools that the IOA is being used by i5/OS in IOP-less mode. When in IOP-less mode the adapter function is restricted to communicating to IBM ECS on port 0 (modem port). Port 1 is the RVX port and is not supported in IOP-less mode.</p> <p>Port 0 supports V.92 56K PPP, V.92 data modem and V.44 data compression. Port 0 does not provide synchronous modem capabilities (SDLC and Synchronous PPP).</p> <p>Select one of the following cables to attach to port 0 (modem port):</p> <ul style="list-style-type: none">▶ #1010 Modem Cable - Austria▶ #1011 Modem Cable - Belgium▶ #1012 Modem Cable - Africa▶ #1013 Modem Cable - Israel▶ #1014 Modem Cable - Italy▶ #1015 Modem Cable - France▶ #1016 Modem Cable - Germany▶ #1017 Modem Cable - UK▶ #1018 Modem Cable - Iceland/Sweden▶ #1020 Modem Cable - HK/NZ▶ #1021 Modem Cable - Fin/Nor▶ #1022 Modem Cable - Netherlands▶ #1023 Modem Cable - Swiss▶ #1024 Modem Cable - Denmark▶ #1025 Modem Cable - US/Canada <p>The #6803 does not support the remote ring indicate function. This feature has country or region specific usage.</p> <p>Minimum operating system level: i5/OS V5R3 and LIC V5R3M5 for Model 520+; or i5/OS V5R4 for Models 550+, 570+, 595 1.9 GHz POWER5 I/O tower running i5/OS V5R4</p>
----------------	---

<p>#6804 #9794</p>	<p>#6804 PCI WAN for ECS (CIM)</p> <p>The #6804 is a WAN w/modem adapter which provides connectivity for IBM Electronic Customer Support (ECS) only. This feature is the Complex Impedance Matching (CIM) version offered in Australia and New Zealand. The #6804 is functionally equivalent to #0615/#2794/#979. The #6804 indicates that the IOA is being used by i5/OS in IOP-less mode. When in IOP-less mode the adapter function is restricted to communicating to IBM ECS on port 0 (modem port). Port 1 is the RVX port and is not supported in IOP-less mode.</p> <p>Port 0 supports V.92 56K PPP, V.92 data modem and V.44 data compression. Port 0 does not provide synchronous modem capabilities (SDLC and Synchronous PPP).</p> <p>Select one of the following cables to attach to port 0 (modem port):</p> <ul style="list-style-type: none"> ▶ #1010 Modem Cable - Austria ▶ #1011 Modem Cable - Belgium ▶ #1012 Modem Cable - Africa ▶ #1013 Modem Cable - Israel ▶ #1014 Modem Cable - Italy ▶ #1015 Modem Cable - France ▶ #1016 Modem Cable - Germany ▶ #1017 Modem Cable - UK ▶ #1018 Modem Cable - Iceland/Sweden ▶ #1020 Modem Cable - HK/NZ ▶ #1021 Modem Cable - Fin/Nor ▶ #1022 Modem Cable - Netherlands ▶ #1023 Modem Cable - Swiss ▶ #1024 Modem Cable - Denmark ▶ #1025 Modem Cable - US/Canada ▶ #0348 - V.24/EIA232 20-ft PCI Cable <p>The #6804 does not support the remote ring indicate function. This feature has country or region specific usage.</p> <p>Minimum operating system level: i5/OS V5R3 and V5R3M5 LIC for Model520+; i5/OS V5R4 for Models 550+, 570+, 595 1.9 GHz</p> <p>Supported on Models 520+, 550+, 570+, 595, and as IOP-less in any POWER5 I/O tower running i5OS V5R4.</p>
------------------------	---

#9812	<p>#9812 PCI-X Integrated xSeries Server</p> <p>The #9812 is a double wide PCI card which contains a 2.0 GHz processor with 2 MB integrated L2 cache. It has two integrated 1000/100/10 Mbps Ethernet ports, two USB 1.1 ports and traditional PC keyboard and mouse ports. A keyboard and mouse can either connect to the traditional ports or connect to the USB ports. There is an SVGA video port for connection of a display.</p> <p>The #9812 has two memory slots. These slots must always contain a pair of identical memory features. Available memory features are:</p> <ul style="list-style-type: none"> ▶ #0446 - 512 MB DDR Server Memory (MES only) ▶ #0447 - 1 GB DDR Server Memory (MES only) ▶ #8546 - Opt Base 1 GB Server Memory (Initial order only) ▶ #9726 - Base 512 MB Server Memory (Initial order only) <p>The #9812 requires a #2844, #9744, or #9844 IOP to drive it. The IOP can be shared, but only one #9812 is permitted per IOP.</p> <p>When #9812 is ordered, the configurator adds two #9726 Base 512 MB Server Memory features to the order. The two #9726 features can be replaced with two #8546 Optional Base 1 GB Server Memory features or the two server memory features can be removed from the order and two #0446 or two #0447 can be installed in the field. The configurator also adds a #9744 Base PCI IOP to drive the #9812. The #9744 can be removed from the order for PCI slot conservation.</p> <p>The two integrated 1000/100/10 Mbps Ethernet LAN ports included on the #9812 provide attachment to IEEE standard 802.3ab high-speed (1 Gbps) Ethernet LANs. They can also be used to connect to existing 10 and 100 Mbps Ethernet networks. The adapter supports UTP CAT 5 or higher media interface and TCP/IP. The #9812 does not support any other LAN features and does not support native i5/OS functions.</p> <p>The following features are defaulted (where offered) and can be removed from the order:</p> <ul style="list-style-type: none"> ▶ #0325 IPCS Extension Cable for Windows (for display, mouse and keyboard) ▶ #1700 IPCS Keyboard and Mouse for Windows <p>The supported Windows versions are:</p> <ul style="list-style-type: none"> ▶ Windows 2000 Server ▶ Windows 2000 Advanced Server ▶ Windows Server 2003 Standard Edition ▶ Windows Server 2003 Enterprise Edition ▶ Windows Server 2003 Web Edition <p>A display for versions of Windows 2000 is required and must be connected to the #9812. A display is not required for versions of Windows 2003 but can be connected to the #9812 to support Windows. If no display is connected, the Virtual System Console is used.</p> <p>For Linux server products supported on the #9812, see: http://www.ibm.com/eserver/iseries/integratedxseries/linux</p> <p>An IOP and two 3.3V PCI card slots are required.</p> <p>The #9812 functionally identical to #4812 but is included in the base with orders for Enterprise Editions on Models 550 and 595.</p> <p>Minimum operating system level: i5/OS V5R3 Supported on Models 550 and 595</p>
#9813	<p>#9813 PCI-X Integrated xSeries Server</p> <p>The #9813 is functionally identical to #4813 but is included in the base with orders for Enterprise Editions on system Model 570. See “#4811 #4812 #4813 #9812 #9813” on page 206.</p>

#9771	<p>#9771 Base PCI 2-Line WAN with integrated modem</p> <p>The #9771 is a 2-Line WAN adapter. One port supports V.90 56K async data on PPP via an internal modem. The second port supports multiple protocol communications (WAN). Connection to the V.90 port uses a telephone cable. Connection to the WAN communication port is through one of the following cables:</p> <ul style="list-style-type: none"> ▶ #0348 V.24/EIA232 20-ft (6 m) PCI cable ▶ #0349 V.24/EIA232 50-ft (15 m) PCI cable ▶ #0353 V.35 20-ft PCI cable ▶ #0354 V.35 50-ft PCI cable ▶ #0356 V.36 20-ft PCI cable ▶ #0359 X.21 20-ft PCI cable ▶ #0360 X.21 50-ft PCI cable ▶ #0365 V.24/EIA232 80-ft PCI cable ▶ #0367 Operations Console PCI Cable <p>The #9771 supports the #0367 Operations Console PCI Cable on the WAN (RVX) port to directly connect the Operations Console for OS/400 V5R1 or later or with OS/400 V4R5 and PTF MF25397. Direct connection of the Operations Console is mutually exclusive with V.90 support of the <i>dial-in</i> Operations Console.</p> <p>The #9771 supports the #5544 System Console on Operations Console on the V.90 port for <i>dial-in</i> Operations Console with V5R1. An additional #4745 on OS/400 V4R5 systems is required for <i>dial-in</i> Operations Console support. The #9771 ships with a country- or region-specific telephone cable. A modem cable feature is not required on the order. ECS is supported over TCP/IP on the V.90 telephone cable port with V5R1, or with OS/400 V4R5 and PTF SF64124. Fax is supported on the V.90 port with V5R1, or with OS/400 V4R5 and PTFs MF25290 and SF64604.</p> <p>To support ECS on the WAN port of the #9771, specify one of the following cables:</p> <ul style="list-style-type: none"> ▶ #0348 V.24/EIA232 20-ft (6 m) PCI cable (default) ▶ #0349 V.24/EIA232 50-ft (15 m) PCI cable ▶ #0365 V.24/EIA232 80-ft PCI cable <p>ECS operates on the WAN port of the #9771 by changing the *RSRCNAME parameter of the QESLINE and QTILINE line descriptions to that of the WAN port on the #9771 card.</p> <p>Remote Power On is not supported. The #9771 does not support the remote ring indicate function.</p> <p>For further configuration information, see: http://www.iseries.ibm.com/tstudio/planning/esa/esa.htm</p> <p>See the "Soft rules: iSeries IOA requirements" topic in <i>PCI and PCI-X Placement Rules for IBM System i5, eServer i5, and iSeries servers with i5/OS V5R4 and V5R3</i>, REDP-4011, or <i>PCI Card Placement Rules for the IBM @server iSeries Server OS/400 Version 5 Release 2: September 2003</i>, REDP-3638 for OS/400 V5R2 and earlier releases, for additional restrictions.</p> <p>Minimum operating system level: OS/400 V4R5 with supporting PTFs</p> <p>The #9771 is withdrawn from marketing as of 01 October 2005.</p>
-------	--

4.9 Disk units

Disk units	
Disk model identifier	<p>The system configuration list (rack configuration) shows the disk type and model in the format XXXX-YYY, where the XXXX identifies the CCIN number of the disk and YYY identifies the potential or actual disk protection and compression. Refer to Chapter 8, "Customer Card Identification Numbers cross reference" on page 303, for a listing of the CCIN numbers.</p> <p>The YYY identifiers are:</p> <p>030: Unprotected or mirrored unit attached to a non-RAID capable controller. 050: Unprotected or mirrored unit attached to a RAID capable controller. 060: Unprotected or mirrored unit attached to a RAID capable controller. Data compression is active. 070: Non-parity member of a parity (RAID) set. Full capacity. Data compression is inactive. 071: Parity member of a parity (RAID) set with sixteen parity members. Fifteen-sixteenths capacity. Data compression is inactive. 072: Parity member of a parity (RAID) set with eight parity members. Seven-eighths capacity. Data compression is inactive. 074: Parity member of a parity (RAID) set with four parity members. Three-fourths capacity. Data compression is inactive. 078: Parity member of a parity (RAID) set with two parity members. Half capacity. Data compression is inactive. 080: Non-parity member of a parity (RAID) set. Full capacity. Data compression is active. 082: Parity member of a parity (RAID) set with eight parity members. Seven-eighths capacity. Data compression is active. 084: Parity member of a parity (RAID) set with four parity members. Three-fourths capacity. Compression is active. 099: Parity member of a parity (RAID) set. 090: Non-parity member of a parity (RAID) set. Full capacity.</p>
Disk data rate	<p>IBM System i5 15K RPM disk drives from January 2006 onward support data rates up to 320 MBs with the proper disk controller. Disk controllers which support disk data rates up to 320 MBs (U320 or Ultra4 SCSI interface) include the #0647, #0648, #2780, #5580, #5736, #5737, #5766, #5775, and #5776. The data rate is not a significant performance factor compared to other specifications such as the cache size and the disk RPM.</p>
#0040	<p>#0040 Mirrored System Disk Level Protection Capability This code indicates the level of disk protection desired and helps ensure that adequate hardware is in the final configuration.</p> <p>For new systems: Causes the order to fail if sufficient disk units are not ordered to support device-level mirrored protection. The #0040 causes all disk units to be placed into configurations capable of implementing mirrored pairs.</p> <p>For upgrade orders: The #0040 causes a warning message to be generated during implementation of mirroring if sufficient disk units are unavailable to provide mirror capability. The customer is responsible for starting mirroring on their system. Mirrored system disk level protection requires all disk units to be placed into mirrored pairs and mirroring be started. The load source must be controlled by the first disk controller on the first system bus and must be mirrored to a like disk unit also attached to the first disk controller on the first system bus. Refer to: http://publib.boulder.ibm.com/pubs/html/as400/infocenter.htm</p> <p>Logically partitioned systems require additional planning. The minimum number of disks allowed on a system is two.</p>
#0041	<p>#0041 Device Parity Protection Capability The #0041 Device Parity Protection Capability indicates the level of disk protection desired and helps ensure that adequate hardware is in the final configuration. The #0041 is the default specify code for data protection capability.</p> <p>For new systems, the #0041 causes the order to fail if a disk unit or adapter is ordered that is not capable of implementing RAID protection. The #0041 causes all internal disk units to be placed into configurations capable of implementing RAID arrays using a RAID-capable disk controller.</p> <p>For upgrade orders, the #0041 causes the order to replace adapters that are not RAID-capable with RAID-capable adapters. A warning message is generated during RAID enablement if there are not enough disk units to support a minimum RAID configuration.</p> <p>It is the customer's responsibility to start RAID on their system. Device parity protection requires all disk units to be placed in sets large enough to turn on RAID protection, as well as be connected to a RAID-capable adapter. The rules for RAID can be found in the disk controller descriptions.</p>

#0042	<p>#0042 Mirrored System IOP Level Protection Capability The #0042 Mirrored System IOP Level Protection Capability indicates the level of disk protection desired and helps ensure that adequate hardware is in the final configuration.</p> <p>For new systems, the #0042 causes the order to fail if sufficient disk units and IOPs are not included on the order to support IOP-level mirrored protection. The #0042 causes all disk units to be placed into configurations capable of IOP-level mirroring. Each disk unit and its mirrored pair must be on a different disk unit IOP.</p> <p>For upgrade orders, the #0042 causes a warning message to be generated during implementation of the upgrade if sufficient disk units, adapters, and IOPs are not available to provide the capability to enable IOP-level mirrored protection for all DASD. It is the customer's responsibility to start mirroring on their system.</p> <p>The load source disk unit in a new, preloaded system is device-level mirrored. (This is the same protection as provided with #0040.) This means that the load source is controlled by the first disk unit controller on the first system bus, and is mirrored with a like disk unit, which is also attached to the same first disk controller on the first system bus. The minimum number of disks allowed on a system is four.</p>
#0043	<p>#0043 Mirrored System Bus Level Protection Capability The #0043 Mirrored System Bus Level Protection Capability indicates the level of disk protection desired and helps ensure that adequate hardware is in the final configuration.</p> <p>For new systems, the #0043 causes the order to fail if sufficient disk units, IOPs and expansion units are not included on the order to support bus-level mirrored protection for all disk units.</p> <p>The load source disk unit in a new, preloaded system is device-level mirrored. This means that the load source is controlled by the first disk controller on the first system bus, and is mirrored with a like disk unit which is also attached to the same first disk controller on the first system bus. Bus level mirroring of the Load Source disk unit can be achieved only by enabling Remote Load Source Mirroring before starting Mirrored Protection. For details about implementing Remote Load Source Mirroring, refer to the iSeries Information Center at: http://publib.boulder.ibm.com/pubs/html/as400/infocenter.htm</p> <p>For upgrade orders, a warning message is generated during installation of the upgrade if sufficient disk units, IOPs, and expansion units are not available to provide the capability to enable bus-level mirrored protection for all disk units. It is the customer's responsibility to start mirroring on their system.</p> <p>Bus-level mirroring requires all disk units to be placed into mirrored pairs on separate busses. Refer to the iSeries Information Center for important Mirrored Protection and Remote Load Source Mirroring implementation details. Logically partitioned systems require additional planning. The minimum number of disks allowed on a system is four.</p>
#0047	<p>#0047 Device Parity RAID-6 All The #0047 code indicates the level of disk protection desired and helps ensure that adequate hardware is in the final configuration.</p> <p>For new systems, the #0047 causes the order to fail if a disk unit or adapter is ordered that is not capable of implementing RAID-6 protection. The #0047 causes all internal disk units to be placed into configurations capable of implementing RAID-6 arrays using a RAID-6 capable disk controller.</p> <p>RAID-6 arrays require a minimum of four disk units per array (all disk units within an array must be of the exact same capacity). The exception to this configuration rule is that the disk drives inside the Model 520, 550 and 570 system units use RAID-5 arrays since the integrated disk controllers are not capable of RAID-6.</p> <p>For upgrade orders, the #0047 causes the order to replace adapters that are not RAID-6 capable with RAID-6 capable adapters. A warning message is generated during RAID enablement if there are not enough disk units to support a minimum RAID configuration.</p> <p>It is the customer's responsibility to start RAID on their system.</p> <p>Device parity protection requires all disk units to be placed in sets large enough to turn on RAID protection, as well as be connected to a RAID-capable adapter. The rules for RAID can be found in the disk controller descriptions.</p>

#08xx	<p>#08xx Load Source Specify Codes Beginning with the V5R1 announcement, requires one of the following specify codes on all initial order for Model 800, 810, 820, 825, 830, 840, 870, and 890s. In addition, one of the following specify codes is required on all upgrades into this model range from previous models:</p> <ul style="list-style-type: none"> ▶ #0826 - #4314 Load Source specify ▶ #0827 - #4324 Load Source specify ▶ #0828 - #4317 Load Source specify ▶ #0829 - #4318 Load Source specify ▶ #0830 - #4319 Load Source specify ▶ #0834 - #4326 Load Source specify ▶ #0835 - #4327 Load Source specify <p>Manufacturing uses the #08xx specify to place a corresponding disk unit feature in the load source position. Initial orders and model upgrade orders into the Model 800, 810, 820, 825, 830, 840, 870, and 890 from previous models that contain a load source specify, but no corresponding disk unit feature, are invalid orders. The following specify codes can be changed on model upgrades or on MES orders.</p> <p>A Load Source specify code is required on each new or upgrade order into 520, 550, 570, and 595 models. These specifies can be changed at any time.</p> <ul style="list-style-type: none"> ▶ #0836 - #4328 Load Source specify <p>The #0826, #0827, #0828 and #0829 are withdrawn from marketing as of 01 June 2006.</p>
#1894	<p>#1894 73.4 GB 10K rpm Disk Unit The #1894 provides a 10,000 RPM Disk Unit with 73.4 GB of storage capacity and an ULTRA320 SCSI interface.</p> <p>Supported only with AIX and Linux. Supported on Models 520, 550, 570 and 595. Supported only during a model conversion on a 595. No additional quantities can be ordered for the Model 595. The #1894 is a Customer Install Feature.</p>
#1895	<p>#1895 146.8 GB 10K rpm Disk Unit The #1895 provides a 10,000 RPM Disk Unit with 146.8 GB of storage capacity and an ULTRA320 SCSI interface.</p> <p>Supported only with AIX or Linux. Supported on Models 520, 550, 570 and 595. Supported only during a model conversion on a 595. No additional quantities can be ordered for the Model 595. The #1895 is a Customer Install Feature.</p>
#1896	<p>#1896 36.4 GB 15K rpm Disk Unit The #1896 provides a 15,000 RPM Disk Unit with 36.4 GB of storage capacity and an ULTRA320 SCSI interface.</p> <p>Supported only with AIX or Linux. Supported on Models 520, 550, 570 and 595. The #1896 is a Customer Install Feature.</p>
#1897	<p>#1897 73.4 GB 15K rpm Disk Unit The #1897 provides a 15,000 RPM Disk Unit with 73.4 GB of storage capacity and an ULTRA320 SCSI interface.</p> <p>Supported only with AIX and Linux. Supported on Models 520, 550, 570 and 595. The #1897 is a Customer Install Feature.</p>
#1898	<p>#1898 146.8GB Disk Unit The #1898 146.8GB Disk Unit provides a 15,000 rpm disk unit with 146.8 GB of storage capacity for AIX 5L and Linux partitions and an ULTRA320 SCSI interface. This disk drive requires attachment to a supported Ultra320 SCSI adapter in a system that supports an Ultra320 SCSI cable/backplane in order for the drive to run at 320 MBs. All other SCSI devices on the same SCSI bus must also be Ultra2, Ultra3, or Ultra320 SCSI devices in order for this disk drive to run at 320 MBs.</p> <p>Not supported by i5/OS. Supported only by AIX and Linux. Supported on Models 520+, 550+, 570+, 595 1.9 GHz, 520, 550, 570, and 595. The #1898 is a Customer Install Feature.</p>

#3578	<p>#3578 - 300 GB 10K rpm Disk Unit The #3578 provides a 10,000 RPM disk unit with 300 GB of storage capacity and an industry-standard Ultra3 SCSI interface speed of up to 160 MBps.</p> <p>Not supported by i5/OS. Supported only by AIX or Linux. Supported on Models 520, 550, 570. Supported only during a model conversion on a Model 595. No additional quantities can be ordered for the Model 595.</p>
#4308	<p>#4308 4.19 GB Disk Unit The #4308 provides an additional 4.19 GB single disk unit with 4.19 GB capacity (7200 RPM).</p> <p>Supported on Models 810, 820, 825, 830, 840, 870, and 890. The #4308 is a Customer Install Feature. The #4308 is withdrawn from marketing as of December 2000.</p>
#4314	<p>#4314 8.58 GB Disk Unit (Ultra SCSI) The #4314 provides an additional 3 ½-inch two-byte single disk unit with 8.58 GB capacity (7200 RPM).</p> <p>Minimum operating system level: OS/400 V4R4 Supported on Models 810, 820, 825, 830, 840, 870, and 890. The #4314 is a Customer Install Feature. The #4314 is withdrawn from marketing as of 31 January 2001.</p>
#4317	<p>#4317 8.58 GB 10k RPM Disk Unit (Ultra2 SCSI) The #4317 provides an additional 3 ½-inch single disk unit with 8.58 GB capacity. During MES upgrades, #6717, #6817, #8617, and #8817 8.58 GB disk units can be converted to #4317s. The #4317 is also supported in Linux partitions with SUSE Linux Enterprise Server 9 for POWER or Red Hat Enterprise Linux AS for POWER Version 3, and AIX 5L for POWER V5.2.</p> <p>Minimum operating system level: OS/400 V4R4 Supported on Models 800, 810, 820, 825, 830, 840, 870, and 890. The #4317 is a Customer Install Feature. The #4317 is withdrawn from marketing for new orders on 03 December 2002. Feature conversions to #4317 remain available.</p>
#4318	<p>#4318 17.54 GB 10k RPM Disk Unit (Ultra2 SCSI) The #4318 provides an additional 3 ½-inch single disk unit with 17.54 GB capacity. During MES upgrades, #6718, #6818, #8618, and #8818 8.58 GB disk units can be converted to #4318s.</p> <p>The #4318 is also supported in Linux partitions.</p> <p>Minimum operating system level: OS/400 V4R4 Supported on Model 270, 9406 520, 550, 570, 595, 800, 810 820, 825, 830, 840, 870, 890, and 9411-100. The #4318 is a Customer Install Feature. The #4318 is withdrawn from marketing as of 01 June 2004 for new orders. Conversions to feature #4318 remain available.</p>
#4319	<p>#4319 35.16 GB 10k RPM Disk Unit (Ultra2 SCSI) The #4319 provides an additional 3 ½-inch single disk unit with 35.16 GB capacity. The #4319 is also supported in Linux and AIX partitions with SUSE Linux Enterprise Server 9 for POWER or Red Hat Enterprise Linux AS for POWER Version 3, and AIX 5L for POWER V5.2.</p> <p>Minimum operating system level: OS/400 V5R1 with PTFs identified in Information APAR II13102 at: http://www.ibm.com/eserver/iserries/support Supported on Models 270, 520, 550, 570, 595, 800, 810, 820, 825, 830, 840, 870, 890, and 9411-100. The #4319 cannot be mounted in a #5065 Storage/PCI Expansion Tower. The #4319 is a Customer Install Feature. The #4319 is withdrawn from marketing as of 12 April 2005.</p>
#4324	<p>#4324 17.54 GB Disk Unit (Ultra SCSI) The #4324 provides a 3 ½-inch single disk unit with 17.54 GB capacity for additional disk storage (7200 RPM).</p> <p>Minimum operating system level: OS/400 V4R4 Supported on Models 810, 820, 825, 830, 840, 870, and 890. The #4324 is a Customer Install Feature.</p>

#4326	<p>#4326 35.16 GB 15k RPM Disk Unit (SCSI) The #4326 provides a single 3 ½-inch disk unit for additional disk storage with 35.16 GB capacity (15000 RPM). Quantities of 150 of this feature can be ordered in the IBM marketing configurator as #7508 Quantity 150 of Feature #4326.</p> <p>Minimum operating system level: OS/400 V5R2 Supported in Linux and AIX partitions with SUSE Linux Enterprise Server 9 for POWER or Red Hat Enterprise Linux AS for POWER Version 3, and AIX 5L for POWER V5.2. Supported on Models 520, 570, 800, 810, 825, 870, and 890 system units and base I/O towers, and in the base I/O towers, the #5094 PCI-X Expansion Tower, the #0595/#5095 PCI-X Expansion Tower, and the #5294 1.8m I/O Tower. The #4326 is a Customer Install Feature.</p>
#4327	<p>#4327 70.56 GB 15k RPM Disk Unit (SCSI) The #4327 provides a 3 ½-inch single disk unit for additional disk storage with 70.56 GB capacity (15000 RPM). Quantities of 150 of this feature can be ordered in the IBM marketing configurator as #7509 Quantity 150 of Feature #4327.</p> <p>Minimum operating system level: OS/400 V5R2 Supported in Linux and AIX partitions with SUSE Linux Enterprise Server 9 for POWER or Red Hat Enterprise Linux AS for POWER Version 3, and AIX 5L for POWER V5.2.</p> <p>Supported on Models 520, 550, 570, 595, 800, 810, 825, 870, and 890 system unit and base I/O towers, the #5094 PCI-X Expansion Tower, the #0595/#5095 PCI-X Expansion Tower, and the #5294 1.8m I/O Tower. The #4327 is a Customer Install Feature.</p>
#4328	<p>#4328 - 141.12 GB 15K rpm Disk Unit. The #4328 provides a 15,000 RPM disk unit with 141.12 GB of storage capacity and an Ultra320 SCSI interface. Quantities of 150 of this feature can be ordered in the IBM marketing configurator as #7510 Quantity 150 of Feature #4328.</p> <p>Supported on Models 520, 550, 570, 595, and 9411-100.</p>
#6585	<p>#6585 - DASD Locking Kit Provides a locking mechanism that secures up to four disk units in the Model 520. Two #6585 kits are required to secure all eight available disk units in the Model 520. When #6585 is installed and secured with a user-provided padlock, the disk units cannot be removed easily.</p> <p>Supported on Model 520.</p>
#75xx	<p>#75xx Quantity 150 of Feature #43xx The #75xx features cause 150 of the specified disk units to be shipped. When over 150 disk units are requested in the IBM marketing configurator, a #75xx feature is automatically added for each group of 150 specified. For example, if 180 #4314 8.58 GB Disk Unit are requested, the IBM marketing configurator adds one #7500 and 30 #4314s to the order.</p> <ul style="list-style-type: none"> ▶ #7500 Quantity 150 of Feature #4314 ▶ #7501 Quantity 150 of Feature #4317 ▶ #7502 Quantity 150 of Feature #4318 ▶ #7503 Quantity 150 of Feature #4324 ▶ #7504 Quantity 150 of Feature #4319 (withdrawn from marketing as of 30 August 2005) ▶ #7508 Quantity 150 of Feature #4326 ▶ #7509 Quantity 150 of Feature #4327 <p>Supported on Models 810, 820, 825, 830, 840, 870, and 890. (#7509 not supported on Model 820)</p> <p>The configurator can either generate the following feature or allow users to select this feature as they would any other single disk unit feature. This feature remains on the inventory records.</p> <ul style="list-style-type: none"> ▶ #7510 Quantity of 150 of Feature #4328 <p>Supported on Models 520, 550, 570, 595, and 9411-100.</p>
RPQ 847102	<p>RPQ 847102 ships the disk mounting hardware and instructions required to convert a #6717/#6817 to a #4317, and a #6718/#6818 to a #4318. One RPQ is required for each disk unit to be converted.</p> <p>This conversion allows the customer to move 8.5 GB 10K RPM and 17 GB 10K rpm files from current towers to the #5065, #5066, #5074/#9074, #5075, #5079/#9079 PCI Expansion Towers, the #5094, #5095, #5294 PCI-X Expansion Towers, iSeries Models 270, 800, 810, 820, 825, 830, 840, 870, 890, or eServer i5 Models 520, 550, 570, and 595.</p> <p>Confirm and that there is available space in the existing or on order system or tower for the converted disk units and that the required number of #2748 PCI RAID Disk Unit Controllers are available. After the conversion, process an RPO to add the appropriate number of #4317/#4318 and remove the appropriate number of #6717/#6818 features.</p> <p>RPQ 847102 is installed by an IBM Customer Service Representative.</p>

4.10 Internal tape units and CD-ROM

Internal tape units and CD-ROM	
Supported media	See 7.3, "QIC tape specifications and compatibility for IBM System i5, eServer i5, and iSeries systems" on page 294, for the supported media for each tape device.
#1889 #9689	<p>#1889 80 GB VXA-2 Tape Device</p> <p>The #1889 80 GB VXA-2 Tape Device is a 5.25-inch, half-high, Ultra2 LVD 16-bit tape drive, which provides a high capacity for save/restore and archive functions. This tape drive uses VXA tape data cartridges and is compression capable, providing a capacity of up to 160 GB. It uses a helical scan, rotating head technology and has a SCSI-2 (LVD/SE) asynchronous/synchronous interface. The tape operates in streaming mode.</p> <p>Refer to 7.3, "QIC tape specifications and compatibility for IBM System i5, eServer i5, and iSeries systems" on page 294, for additional characteristics.</p> <p>One 1.6-inch (41 mm) half-high media bay and one SCSI-2 internal 16-bit address is required.</p> <p>Minimum operating system level: i5/OS V5R3 Supported in Linux SUSE Linux Enterprise Server 9 for POWER or Red Hat Enterprise Linux AS for POWER Version 3, and AIX 5L for POWER V5.2 The #1889 is supported as an IOP-less drive in the 9405 520, 9406 520, and Models 520+, 550, and 550+ with a minimum operating system level of i5/OS V5R4 and i5/OS V5R3 with LIC V5R3M5 on Models 520 and 520+. Supported on Models 520 and 550. The #1889 is a Customer Install Feature.</p>
#2640	<p>#2640 DVD-ROM</p> <p>The #2640 DVD-ROM is a Slimline IDE DVD-ROM drive. It uses an internal tray loading DVD-ROM drive. The #2640 provides up to 3600 KBps (CD-ROM) and 10.3 MBps (DVD-ROM) data transfer rates.</p> <p>Characteristics:</p> <ul style="list-style-type: none"> ▶ Media Data Transfer Rate (maximum): CD-ROM=3600 KBps, DVD-ROM=10.3 MBps. ▶ Interface: IDE/ATAPI ▶ Average Random Access Time: CD-ROM=95ms (typical), DVD-ROM=150ms (typical) ▶ Buffer Memory: 256KB ▶ Media capacity: CD-ROM=650 MB, DVD-ROM= 4.7 GB (single sided)/9.4 GB (double-sided) ▶ Multi session capable (Reads CD/R and CD-R/W media) ▶ 12.7 mm Slimline form factor ▶ Operates in either vertical or horizontal positions ▶ Interface supports standard and extended XA formats ▶ Loading tray supports 12cm and 8cm disks ▶ DVD video is not supported <p>Requires one Slimline media bay.</p> <p>Minimum operating system level: i5/OS V5R3 Supported in Linux and AIX partitions with SUSE Linux Enterprise Server 9 for POWER or Red Hat Enterprise Linux AS for POWER Version 3, and AIX 5L for POWER V5.2 Supported on Models 520, 550, and 570. The #2640 is a Customer Install Feature.</p>

<p>#4425 #4525 #4625</p>	<p>#4425/#4525/#4625 CD-ROM</p> <p>The #4425, #4525, or #4625 can be used for alternate IPL (IBM distributed CD-ROM media only) and program distribution. A CD-ROM, DVD-RAM or DVD-ROM is required for each system.</p> <p>Minimum operating system level: for the #4525: OS/400 V4R5 Minimum operating system level: for the #4425: OS/400 V4R4 Supported for migration in Linux and AIX partitions with SUSE Linux Enterprise Server 9 for POWER or Red Hat Enterprise Linux AS for POWER Version 3, and AIX 5L for POWER V5.2</p> <p>The #4425 CD-ROM device can be mounted in the base PCI enclosure of Models 830, 840, 870, and 890, in the #5074/#5079 PCI Expansion Towers, and in the #5094/#5294 Expansion Towers. The #4525 CD-ROM device can be mounted in the system unit of the Model 810 and 820. The #4625 CD-ROM replaces the #4425. The difference between the #4625 and the #4425 is in the mounting hardware. A #4625 can be placed everywhere that a #4425 can be placed, and can also be placed in a Model 825 system unit. The #4425 is not supported in a Model 820 or 825 system unit.</p> <p>The #4425, #4525, and #4625 are Customer Install Features. The #4425 is withdrawn from marketing as of 21 November 2003 for new orders. Conversion to feature #4425 remains available. The #4625 is withdrawn from marketing as of 15 July 2005.</p>
<p>#4430 #4530 #4630</p>	<p>#4430/#4530/#4630 DVD-RAM</p> <p>The #4430/#4530/#4630 reads and writes 4.7 GB on a single-sided media. For double sided media, the media must be manually flipped.</p> <p>The #4430, #4530, or #4630 is capable of reading 640 MB CD-ROM disks. It can read CD-R, DVD-ROM and DVD-R media. The #4430, #4530, or #4630 can be used for alternate IPL, program distribution, and data interchange. It is not supported as an Alternate Installation Device (by selection via DST Boot Manager) with OS/400 V5R1.</p> <p>The #4430 DVD-RAM device can be mounted in the base PCI enclosure of Models 830 and 840, in the #5074/#5079 PCI Expansion Towers, in the #8093 Optional 1.8 M I/O Rack, and in the #9094 Base PCI I/O Enclosure of the Model 890.</p> <p>The #4530 DVD-RAM device can be mounted in the system unit of Models 800, 810, and 820.</p> <p>The #4630 CD-ROM replaces the #4430. The difference between the #4630 and the #4430 is in the mounting hardware. Minimum operating system level: OS/400 V4R5 with PTFs or OS/400 V5R1</p> <p>Supported for migration in Linux and AIX partitions with SUSE Linux Enterprise Server 9 for POWER or Red Hat Enterprise Linux AS for POWER Version 3, and AIX 5L V5.2 A #4630 can be placed everywhere a #4430 can be placed, and can also be placed in a Model 825 system unit. The #4430 is not supported in a Model 825 system unit. The #4430, #4530, and #4630 DVD-RAM are 5 ¼-inch devices which install in a removable media device slot. A disk unit controller is required in the system unit or tower where the device is mounted.</p> <p>The #4430, #4530, and #4630 are Customer Install Features. The #4430 is withdrawn from marketing as of 01 January 2004. A #4630 is the recommended replacement. The #4530 is withdrawn from marketing as of 01 October 2004. A #4533 is the recommended replacement. The #4630 is withdrawn from marketing as of 01 October 2004. A #4633 is the recommended replacement.</p>

<p>#4482 #4582 #4682</p>	<p>#4482/#4582/#4682 4 GB ¼-inch Cartridge Tape Device</p> <p>The #4482, #4582, or #4682 4 GB ¼-inch Cartridge Tape Device can be used for save/restore, alternate IPL, program distribution, migration, and ¼-inch cartridge tape exchange using the appropriate media and density. This tape unit is not compatible with System/36 ¼-inch cartridge tape units.</p> <p>Refer to 7.3, “QIC tape specifications and compatibility for IBM System i5, eServer i5, and iSeries systems” on page 294, for additional characteristics.</p> <p>An available removable media device slot and disk unit controller is required in the system unit or expansion tower in which the device is mounted.</p> <p>Minimum operating system level: for the #4582 and #4682: OS/400 V4R5 Minimum operating system level: for the #4482: OS/400 V4R4</p> <p>Supported for migration in Linux and AIX partitions with SUSE Linux Enterprise Server 9 for POWER or Red Hat Enterprise Linux AS for POWER Version 3, and AIX 5L for POWER V5.2</p> <p>The #4482 is supported in the Model 520 (9406 only), 550, 570, and 595. The #4482 can be mounted in the base PCI enclosure of Models 810, 820, 825, 830 and 840, in the #8093 Optional 1.8 M I/O Rack, and in the #9094 Base PCI I/O Enclosures of the Model 890. It is supported in the Model 870, the #5074/#5079 PCI Expansion Towers the #5094/#5294 Expansion Towers, the #8093 Optional 1.8 M I/O Rack, and the #9094 Base PCI I/O Enclosure of the Model 890.</p> <p>The #4582 can be mounted in the system unit of Models 800, 810, and 820.</p> <p>The #4682 can be mounted in the system unit of Models 520 (9406 only), 550, 570, 595, 800, 810, 820, 825, 830, 840, 870, and 890, in the #5074/#5079 PCI Expansion Towers, and in the #5094/#5294 Expansion Towers.</p> <p>The #4482, #4582, and #4682 are Customer Install Features.</p> <p>The #4482 is withdrawn from marketing as of 01 January 2004.</p> <p>The #4582 is withdrawn from marketing as of 01 October 2005. A #4584 is the recommended replacement.</p> <p>The #4682 is withdrawn from marketing as of 01 October 2005. A #4684 is the recommended replacement.</p>
<p>#4483 #4583 #4683</p>	<p>#4483/#4583/#4683 16 GB ¼-inch Cartridge Tape Device</p> <p>The #4483, #4583, and #4683 16 GB ¼-inch Cartridge Tape Device are 25 GB ¼-inch cartridge tape units that mount in a removable media device slot of a system unit or an expansion drawer or tower. The #4483, #4583, and #4683 16 GB ¼-inch Cartridge Tape Device can be used for save/restore, alternate IPL, migration, and ¼-inch cartridge tape exchange using the appropriate media and density. This tape unit is not compatible with System/36 ¼-inch cartridge tape units.</p> <p>Refer to 7.3, “QIC tape specifications and compatibility for IBM System i5, eServer i5, and iSeries systems” on page 294, for additional characteristics.</p> <p>The #4483 can be mounted in the base PCI enclosure of Models 810, 820, 825, 830 and 840, in the #5074/#5079 PCI Expansion Towers, and is supported via upgrade in the Models 870 and 890. Supported in Models 520 (9406 only), 550, 570, and 595.</p> <p>The #4583 can be mounted in the system unit of Models 810 and 820.</p> <p>The #4683 is supported in the Model 520 (9406 only), 550, 570, 595, 800, 810, 820, 825, 830, 840, 870, and 890 for upgrades only.</p> <p>Supported for migration in Linux partitions with SUSE Linux Enterprise Server 9 for POWER or Red Hat Enterprise Linux AS for POWER Version 3</p> <p>Minimum operating system level: for the #4483: OS/400 V4R4 Minimum operating system level: for the #4583 and #4683: OS/400 V4R5</p> <p>The #4483/#4583/#4683 are Customer Install Features.</p> <p>The #4583 is withdrawn from marketing as of 3 December 2002.</p>

<p>#4486 #4586 #4686</p>	<p>#4486/#4586/#4686 25 GB ¼-inch Cartridge Tape Device</p> <p>The #4486, #4586, and #4686 25 GB ¼-inch Cartridge Tape Device is a 25 GB ¼-inch cartridge tape unit that mounts in a removable media device slot of a system unit or an expansion drawer/tower. The #4486, #4586, and #4686 25 GB ¼-inch Cartridge Tape Device can be used for save/restore, alternate IPL, program distribution, migration and ¼-inch cartridge tape exchange. This tape unit is not compatible with System/36 ¼-inch cartridge tape units.</p> <p>Refer to 7.3, “QIC tape specifications and compatibility for IBM System i5, eServer i5, and iSeries systems” on page 294, for additional characteristics.</p> <p>Minimum operating system level: for the #4486: OS/400 V4R4 Minimum operating system level: for the #4586: OS/400 V4R5 Supported for migration in Linux partitions with SUSE Linux Enterprise Server 9 for POWER or Red Hat Enterprise Linux AS for POWER Version 3.</p> <p>The #4486 is supported by the Model 520 (9406 only), 550, 570, 595, 810, 820, 825, 830, 840, 870, and 890. The #4486 can be mounted in the base PCI enclosure of Models 830, 840, and 890, and in the #5074/#5079 PCI Expansion Towers. The #4586 can be mounted in the system unit of Models 810 and 820. The #4686 can be mounted in the base PCI enclosure of Models 810, 825, 830, 840, 870, and 890, in the #5074/#5079 PCI Expansion Towers, in the #5094/#5294 Expansion Towers, in the #8093 Optional 1.8 M I/O Rack, and in the #9094 Base PCI I/O Enclosure of the Model 890. The #4686 is supported for upgrades only in the Model 520 (9406 only), 550, 570, 590, 820, 830, and 840.</p> <p>The #4486, #4586, and #4686 are Customer Install Features. The #4586 is withdrawn from marketing as of 3 December 2002.</p>
<p>#4487 #4587 #4687 #8287</p>	<p>#4487/#4587/#4687 50 GB ¼-inch Cartridge Tape Device</p> <p>The #4487/#4587/#4687 50 GB ¼-inch Cartridge Tape Device can be used for save/restore, alternate IPL, program distribution, migration, and ¼-inch cartridge tape exchange using the appropriate media and density. These tape units are not compatible with System/36 ¼-inch cartridge tape units. The #8287 is an optional base 50 GB ¼-inch Cartridge Tape Unit for the Model 800 Standard and Advanced Editions. A disk unit controller in the system unit or tower is required where the device is mounted.</p> <p>Refer to 7.3, “QIC tape specifications and compatibility for IBM System i5, eServer i5, and iSeries systems” on page 294, for additional characteristics.</p> <p>Minimum operating system level: OS/400 V5R1 The #4487 and #4687 are supported as an IOP-less drive in the Model 520 with a minimum operating system level of i5/OS V5R3 and LIC V5R3M5, and in the Model 520+ with i5/OS V5R4.</p> <p>The #4487 can be mounted in the base PCI enclosure of the Models 830 and 840, in the #5074/#5079 PCI Expansion Towers, in the #8093 Optional 1.8 M I/O Rack, and in the #9094 Base PCI I/O Enclosure of the Model 890. The #4587 can be mounted in the system unit of Models 270, 800, 810, and 820. The #4687 can be mounted in the base PCI enclosure of Models 825, 870, and 890, in the #5074/#5079 PCI Expansion Towers, and in the #5094/#5294 Expansion Towers. The #8287 can be mounted in a removable media device slot in the Model 800 system unit or in the expansion tower. Supported for migration in Linux and AIX partitions with SUSE Linux Enterprise Server 9 for POWER or Red Hat Enterprise Linux AS for POWER Version 3, and AIX 5L for POWER V5.2.</p> <p>The #4487 is supported in Models 520 (9406 only), 550, 570, 595, 810, 820, 825, 830, 840, 870, and 890. The #4587 is supported in Models 800, 810, and 820. The #4687 is supported in Models 520, 550, 570, 595, 800, 810, 820, 825, 830, 840, 870, and 890. The #8287 is supported in the Model 800. The #4487 and #4687 are supported as an IOP- less drive in Models 9405 520, 9406 520, 520+, 550, and 550+.</p> <p>The #4487, #4587, or #4687 are Customer Install Features. The #4487 is withdrawn from marketing as of 01 January 2004. The #4587 is withdrawn from marketing as of 01 June 2006. The #8287 is withdrawn from marketing as of 01 October 2005.</p>

<p>#4531 #4631</p>	<p>#4531 DVD-ROM/#4631 DVD-ROM</p> <p>The #4531/#4631 DVD-ROM is a 5 ¼-inch device which is mounted in a removable media device slot. The #4531/#4631 is capable of reading 640 MB CD-ROM media and 4.7 GB DVD-RAM media. It is an alternate IPL (IDE bus attach) device, so a SCSI/ATAPI converter card is required and is included with the device. The converter card requires its own power source, so a power flex cable is included.</p> <p>The #4531/#4631 can be used for Alternate IPL (IBM distributed CD-ROM media only) and program distribution. The #4531 can be mounted in the system unit of Models 800, 810, and 820. The #4631 can be mounted in the system unit of Models 820, 825, 830, 840, 870, 890, in the #5074/#5079 PCI Expansion Tower, and in the #5094/#5294 Expansion Towers.</p> <p>A disk unit controller is required in the system unit or tower where the device is mounted. A CD-ROM, DVD-RAM or DVD-ROM is required for each system. The #4531 is supported in the Models 270, 800, 810, and 820. The #4631 is supported in the Models 520, 550, 570, 595, 800, 810, 820, 825, 830, 840, 870, 890, SB2, and SB3.</p> <p>Minimum operating system level: OS/400 V5R2 Supported in Linux and AIX partitions with SUSE Linux Enterprise Server 9 for POWER or Red Hat Enterprise Linux AS for POWER Version 3, and AIX 5L for POWER V5.2. The #4531 and #4631 are Customer Install Features. The #4531 is withdrawn from marketing as of 01 December 2005. The #4631 is withdrawn from marketing for new orders only on 01 December 2005.</p>
<p>#4584 #4684 #9284</p>	<p>#4584 30 GB ¼-inch Cartridge Tape Device/#4684 30 GB ¼-inch Cartridge Tape Device</p> <p>The #4584/#4684, #9284, 30 GB ¼-inch Cartridge Tape Device can be mounted in a removable media device slot of a system unit or an expansion tower. The #4584/#4684, and #9284 can be used for save/restore, alternate IPL, program distribution, migration, and ¼-inch cartridge tape exchange. The #9284 is a base 30 GB ¼-inch Cartridge Tape Unit for the Model 800 Standard and Advanced Editions.</p> <p>Refer to 7.3, "QIC tape specifications and compatibility for IBM System i5, eServer i5, and iSeries systems" on page 294, for additional characteristics.</p> <p>The #4584 is supported in Models 800, 810, and 820. The #4684 is supported in Models 520, 550, 570, 595, 800, 810, 820, 825, 830, 840, 870, and 890. The #4684 is supported as an IOP-less drive in Models 520+, 550+, 570+, 595 1.9 GHz, 520, 550, 570, and 595. The #9284 is supported in the Model 800. The #4584 can be mounted in the system unit of Models 800, 810, and 820. The #4684 can be mounted in the base PCI enclosure of Models 825, 830, 840, 870, and 890, in the #5074/#5079 PCI Expansion Towers, in the #5094/#5294 Expansion Towers, in the #8093 Optional 1.8 M I/O Rack, and in the #9094 Base PCI I/O Enclosure of the Model 890. The #9284 can be mounted in a removable media device slot in the Model 800 system unit or in the expansion tower.</p> <p>Minimum operating system level for the #4584 and #4684: OS/400 V4R5 Minimum operating system level for the #4684 to function as an IOP- less drive: i5/OS V5R4 or i5/OS V5R3 with LIC V5R3M5 for Models 520 and 520+ Minimum operating system level for the #9284: OS/400 V5R2 Supported for migration in Linux and AIX partitions with SUSE Linux Enterprise Server 9 for POWER or Red Hat Enterprise Linux AS for POWER Version 3, and AIX 5L for POWER V5.2.</p> <p>The #4584 and #4684 are Customer Install Features. The #4584 is withdrawn from marketing as of 01 June 2006. The #9284 is withdrawn from marketing as of 01 October 2005.</p>

<p>#4585 #4685 #9285</p>	<p>#4585 80 GB VXA-2 Tape Device/#4685 80 GB VXA-2 Tape Device</p> <p>The #4585 and 4685 can be used for save and restore, alternate IPL, program distribution, and migration. The tape format is not compatible with other tape units currently offered on iSeries systems. The #9285 is a Base 80 GB VXA-2 Cartridge Tape Unit for the Model 800 Standard and Advanced Editions.</p> <p>Refer to 7.3, "QIC tape specifications and compatibility for IBM System i5, eServer i5, and iSeries systems" on page 294, for additional characteristics.</p> <p>The #4585 is supported by the #2757, #2763, #2780, #2782, #4748, #4778, #5705 (Model 800 and 810), and #9767. The #4685 is supported by the #2757, #2763, #2780, #2782, #4748, and #4778.</p> <p>The #4585 is supported in the Models 800, 810, and 820.</p> <p>The #4685 is supported in Models 520, 550, 570, 595, 800, 810, 820, 825, 830, 840, 870, and 890.</p> <p>The #4585 80 GB VXA-2 Tape Device can be mounted in a removable media device slot of a Model 800, 810, or 820 system unit.</p> <p>The #4685 80 GB VXA-2 Tape Device can be mounted in a removable media device slot of a Model 825, 830, 840, 870, or 890 system unit, or a #5065, #5066, #5074, #5079, #5094, #5294 expansion tower.</p> <p>The #9285 can be mounted in a removable media device slot in the system unit or expansion tower.</p> <p>Minimum operating system level: OS/400 V5R1 Supported in Linux and AIX partitions with SUSE Linux Enterprise Server 9 for POWER or Red Hat Enterprise Linux AS for POWER Version 3, and AIX 5L for POWER V5.2.</p> <p>The #4585 and #4685 are Customer Install Features. The #4585 is withdrawn from marketing as of 01 June 2006. The #9285 is withdrawn from marketing as of 01 October 2005.</p>
<p>#4633</p>	<p>#4633 DVD-RAM</p> <p>The #4633 DVD-RAM is a half high optical media device. The #4633 uses cartridgeless media only. This is different from the #4630 DVD-RAM which can use cartridge media. The media can be removed from the cartridge to be used in the #4633. Media support is limited to writing DVD-RAM only and reading of CD-ROM, CD-R, DVD-ROM and DVD-RAM.</p> <p>Minimum operating system level: OS/400 V5R2 Supported in Linux and AIX partitions with SUSE Linux Enterprise Server 9 for POWER or Red Hat Enterprise Linux AS for POWER Version 3, and AIX 5L for POWER V5.2. Supported on Models 520, 550, 570, 595, 800, 810, 820, 825, 830, 840, 870, 890, and in #5074, #5079, #5094, #5294 and #9094 expansion towers. The #4633 is a Customer Install Feature.</p>
<p>#5751</p>	<p>#5751 DVD-RAMM</p> <p>The #5751 DVD-RAM is an IDE DVD slimline device with multiple DVD media read/write capability.</p> <p>Refer to 7.3, "QIC tape specifications and compatibility for IBM System i5, eServer i5, and iSeries systems" on page 294, for additional characteristics.</p> <p>Minimum operating system level: i5/OS V5R3 Supported by i5/OS if placed in the top slimline bay. Supported in Linux and AIX partitions if placed in the bottom slimline bay. Supported in system unit of Models 520, 550, and 570. The #5751 is a Customer Install Feature.</p>

<p>#5753 #9653</p>	<p>#5753 30 GB ¼-inch Cartridge Tape Device / #9653 Base 30 GB ¼-inch Cartridge Tape Unit The #5753/#9653 is a 30 GB ¼-inch Cartridge Tape Unit that can be mounted in a removable media device slot in the system unit. The #5753 can be used for save/restore, alternate IPL, program distribution, migration and ¼-inch Cartridge Tape exchange. The #9653 is a base 30 GB 1/4-Inch Cartridge Tape Unit for System i5 Express Configurations.</p> <p>Refer to 7.3, “QIC tape specifications and compatibility for IBM System i5, eServer i5, and iSeries systems” on page 294, for additional characteristics.</p> <p>Minimum operating system level: i5/OS V5R3 Minimum operating system level for the #4684, #5753, and #9653 to function as an IOP-less drive: i5/OS V5R4; or i5/OS V5R3 with LIC V5R3M5 on Models 520 and 520+ Supported in Linux and AIX partitions with SUSE Linux Enterprise Server 9 for POWER or Red Hat Enterprise Linux AS for POWER Version 3, and AIX 5L for POWER V5.2.</p> <p>Supported on Models 520, 550, 570, 595. The #5753 can be mounted in Models 9405 520, 520+, and 550+. The #9653 can be mounted in a removable media device slot of a 9405 520+ and 9406 520+. The #5753 and #9653 are supported as an IOP-less drive on the Models 9405 520, 9406 520 and 520+.</p> <p>The #5753 is a Customer Install Feature. The #9653 is withdrawn from marketing as of 01 April 2005.</p>
<p>#5754 #8754</p>	<p>#5754 50 GB ¼-inch Cartridge Tape Device / #8754 Optional Base 50 GB ¼-inch Cartridge Tape Unit The #5754 is a 50 GB ¼-inch Cartridge Tape Unit that can be mounted in a removable media device slot of a system unit. The #5754 can be used for save/restore, alternate IPL, program distribution, migration and ¼-inch Cartridge Tape exchange.</p> <p>Refer to 7.3, “QIC tape specifications and compatibility for IBM System i5, eServer i5, and iSeries systems” on page 294, for additional characteristics.</p> <p>Minimum operating system level: i5/OS V5R3 Minimum operating system level for the #5754 to function as an IOP-less drive: i5/OS V5R4; or i5/OS V5R3 with LIC V5R3M5 on Models 520 and 520+. Supported in Linux and AIX partitions with SUSE Linux Enterprise Server 9 for POWER or Red Hat Enterprise Linux AS for POWER Version 3, and AIX 5L for POWER V5.2.</p> <p>Supported on Models 520 and 550. The #5754 is supported as an IOP-less drive in the 520+, 550+, 9405 520, 9406 520, 550. The #5754 is a Customer Install Feature. The #8754 is withdrawn from marketing as of 15 October 2004.</p>
<p>#5755</p>	<p>#5755 - 200 GB LTO-2 Tape Unit Provides a 200 GB native capacity (400 GB compressed capacity) tape device which installs in a half-high removable media device slot in the system unit. The #5755 can read and write both LTO Gen-1 and LTO Gen-2 tape cartridges.</p> <p>The characteristics are: Capacity: 200 GB native Compression Mode: 400 GB Form factor: 5.25-inch, half-high Media: LTO Gen-1 or LTO Gen-2 Data Cartridge Technology: Linear Tape Open Data rate (compressed): 48 MBps Interface: SCSI-3 low voltage differential (LVD)/single ended (SE) Refer to 7.4, “VXA and LTO tape specifications and compatibility for IBM System i5, eServer i5, and iSeries systems” on page 295, for additional characteristics.</p> <p>Minimum operating system level: i5/OS V5R3, AIX 5L for POWER V5.2 for IBM eServer, Red Hat Enterprise Linux AS for POWER Version 3, SUSE Linux Enterprise Server 9 for POWER Minimum operating system level for the #5755 to function as an IOP-less drive: i5/OS V5R4; or i5/OS V5R3 with LIC V5R3M5 for Model 520. Supported on Models 520 and 550. The #5755 is supported as an IOP-less drive on Models 520, 520+, 550, and 550+. The #5755 is a Customer Install Feature.</p>

#6134	<p>#6134 60 GB 8 mm Tape Device</p> <p>The #6134 is an 8 mm, 5.25-inch half-high, 16-bit, internal Auto-docking tape drive, usable with a Linux operating system only. The #6134 provides a high capacity tape drive for save/restore and archiving functions. This tape drive uses IBM 8 mm data cartridges and is compression capable, providing a capacity of up to 150 GB.</p> <p>The characteristics are:</p> <ul style="list-style-type: none"> ▶ Capacity: 60 GB native mode ▶ Compression Mode, 150 GB (typical) ▶ Form factor: 5.25-inch Half-high ▶ Media: IBM 8 mm Data Cartridge with Smart Clean Technology ▶ Technology: Helical Scan, Rotating Head ▶ Operation: Streaming ▶ Data Transfer Rate: 12 MBps native mode, 30 MBps typical ▶ Interface: SCSI-2 16-bit Low Voltage Differential (LVD)/Single-ended (SE) Asynchronous/Synchronous <p>Minimum operating system level: SUSE Linux Enterprise Server 9 for POWER or Red Hat Enterprise Linux AS for POWER Version 3. Supported on Models 520 and 550. The #6134 is a Customer Install Feature. The #6134 is withdrawn from marketing as of 24 June 2005. A #6120 or #6169 are the recommended replacements.</p>
#6279	<p>#6279 160 GB VXA-320 Tape Drive</p> <p>The #6279 160 GB VXA-320 Tape drive is a 5.25-inch, half-high, Ultra2 SCSI tape drive, which provides a high capacity for save/restore and archive functions. This tape drive uses VXA tape data cartridges and is compression capable, providing a capacity of up to 320 GB.</p> <p>Characteristics: Form Factor: 5.25-inch, half-high Media: uses VXA tape data cartridges Technology: Helical scan, rotating head Operation: Streaming Interface: Ultra2 SCSI, 16-bit (wide), LVD and SE compatible Refer to 7.4, "VXA and LTO tape specifications and compatibility for IBM System i5, eServer i5, and iSeries systems" on page 295, for additional characteristics.</p> <p>The #6279 is driven by the embedded disk or tape controller depending upon configuration, either IOP based or IOP-less.</p> <p>Minimum operating system level: i5/OS V5R3, Red Hat Enterprise Linux AS for POWER Version 3, SUSE Linux Enterprise Server 9 for POWER, AIX 5L for POWER V5.2 for IBM eServer Supported in Models 520+, 550+, 9405 and 9406 520, 550. The #6279 is a Customer Install Feature.</p>
RPQ 847184	<p>RPQ 847184 provides the mounting hardware to convert selected iSeries #63xx/#64xx tape features into #45xx equivalents for installation in iSeries systems. See the RPQ description for a complete list of applicable conversions.</p>

4.11 Magnetic media controllers

Magnetic media controllers	
#0165	<p>#0165 VHDCI attachment</p> <p>The #0165 VHDCI attachment is used to indicate that an external CD/DVD/tape device is to be attached to a #5702 PCI-X Ultra Tape Controller, #5705 PCI-X Tape/DASD Controller, #5712 PCI-X Tape/DASD Controller, or #5715 PCI-X Tape/DASD Controller.</p> <p>Supported on Models 520, 550, 570, 595, 800, 810, 820, 825, 830, 840, 870, and 890.</p>
#0618	<p>#0618 - Direct Attach #2757 PCI-X Ultra RAID Disk Controller</p> <p>The #0618 is the Linux direct attach feature for the #2757 PCI-X Ultra RAID Disk Controller.</p> <p>Supported on Models 800, 810, 820, 825, 830, 840, 870, and 890. The #0618 is withdrawn from marketing as of 01 June 2006. A #0627 - Direct Attach #2780 PCI-X Ultra4 RAID Disk Controller is the recommended replacement.</p>

#0647	<p>#0647 PCI-X Disk/Tape Controller without IOP The #0647 provides a PCI-X Disk/Tape SCSI Controller with zero write cache and without RAID support. The #0647 is the Linux direct attach feature for the #5736 PCI-X Disk/Tape Controller with IOP.</p> <p>A maximum of six disk drives are supported on the #0647. Removable media devices (tape, optical libraries, CD-ROM, DVD-ROM, and DVD-RAM) are also supported.</p> <p>The #0647 has two U320 buses each with a bus data rate of up to 320 MBs. Each SCSI bus can be either internal (using an internal port) or external (using an external port), but not both. There are four physical ports on the #0647, two internal and two external. Internal devices connect to the internal ports (1 or 2). External devices connect to the external ports (1 or 2) and use an Low Voltage Differential (LVD) interface and VHDCI connectors. A #1850 VHDCI to P Converter Cable is available to connect to external devices with type P connectors.</p> <p>The #0647, #5736, #5766, and #5775 are physically the same adapter card. An #0647 indicates that the card is dedicated to an AIX 5L or Linux partition and an IOP is not being used.</p> <p>Supported on Models 520+, 550+, 570+, 595 1.9 GHz, 520, 550, 570, 595, 800, 810, 825, 870, 890, 270, 820, 830, and 840.</p>
#0648	<p>#0648 PCI-X Disk Controller 90MB without IOP The #0648 is the Linux direct attach feature for the #5737 PCI-X Disk Controller 90MB with IOP. The #0648 has two U320 SCSI buses each with a bus data rate of up to 320 MBs. A maximum of 12 internal disk drives and up to two internal removable media devices (tape, CD-ROM, DVD-ROM or DVD-RAM) are supported on the #0648.</p> <p>A minimum of three disk drives are required for RAID-5, providing protection against a single drive failure in an array. A minimum of four disk drives are required for RAID-6, providing protection against up to two drives failing in an array.</p> <p>The #0648, #5737, and #5776 are physically the same adapter card.</p> <p>The #2780/#5580 and #2757/#5581 disk controllers with an effective 757 MB write cache provide greater disk performance and can have an auxiliary write cache IOA to protect the write cache contents.</p> <p>Supported on Models 520+, 550+, 570+, 595 1.9 GHz, 520, 550, 570, 595, 800, 810, 825, 870, 890, 270, 820, 830, and 840.</p>
#0705	<p>#0705 Forced #2749 Placement The #0705 Forced #2749 Placement forces placement of a #2749 PCI Ultra Magnetic Media Controller in the first Multi-adapter Bridge Boundary of the system. With this configuration, using the Alternate Install Device Option via DST is not required. Any device attached to that #2749 is then the Alternate-IPL device.</p> <p>Supported on Models 520 (9406 only), 570, 595, 800, 810, 870, 890.</p> <p>The #0705 is withdrawn from marketing as of 01 April 2005.</p>
#0707	<p>#0707 Forced #2768 Placement The #0707 Forced #2768 Placement forces placement of a #2768 PCI Magnetic Media Controller IOA in the first Multi-adapter Bridge Boundary of the system. With this configuration, using the Alternate Install Device Option via DST is not required. Any device attached to that #2768 is then the Alternate-IPL device.</p> <p>Supported on Models 520 (9406 only), 550, 800, 810, 870, and 890.</p> <p>The #0707 is withdrawn from marketing as of 01 April 2005.</p>
#0708	<p>#0708 Forced #5702 Placement The #0708 Forced #5702 Placement forces placement of a #5702 PCI-X Ultra Tape Controller IOA in the first Multi-adapter Bridge Boundary of the system. With this configuration, using the Alternate Install Device Option via DST is not required. Any device attached to that #5702 is then the Alternate-IPL device.</p> <p>Supported on Models 520, 550, 570, 595, 800, 810, 870, 890.</p>

#2749

#2749 PCI Ultra Magnetic Media Controller

The #2749 is an Ultra SCSI IOA that provides attachment capability for external tape devices and external optical devices. The #2749 can attach one tape drive or one optical drive. The following tape devices can be attached:

- ▶ 3490E E01/E11 ½-inch cartridge tape subsystem
- ▶ 3490 F00/F01/F11/F1A ½-inch cartridge tape subsystem
- ▶ 3490E C11/C22/C1A/C2A with feature #5040
- ▶ 3494 Tape Library Data server
 - L10 Library Control Unit Frame 1 3490E C1A/C2A with #5040 or 1-2 3490E F1A
 - L12 Library Control Unit Frame 1-2 3590 B1A
 - D10 Device Frame 1 3490E C1A/C2A with #5040 or 1-2 3490E F1A, 300 cartridges
 - D12 Device Frame 1-6 3590 B1A, 300 cartridges
 - HA1 (High Availability): Two L1X and two D1X for redundancy
- ▶ 3570 0.31-inch Cartridge Tape Subsystem
 - Model B0x, C0x (stand-alone)
 - Model B1x, C1x (rack mount)
 - Model B1A, C1A (mounts in 3575)
- ▶ 3575 0.31-inch Cartridge Tape Subsystem
 - Model Lxx
- ▶ 3580-Hxx Ultrium Tape Drive
- ▶ 3581-H17 Ultrium Tape Autoloader
- ▶ 3582-L23 Ultrium Tape Library, HVD drive feature
- ▶ 3583-Lxx Ultrium Scalable Tape Library, HVD drive feature
- ▶ 3584-L32 or D32 Ultra scalable Tape Library, HVD drive feature
- ▶ 3590 ½-inch Cartridge Tape Subsystem
 - Models B11, E11, and H11 (mounts into 9309 rack)
 - Models B1A, E1A, and H1A (mounts into 3494 library)
- ▶ 3995 Optical Library Data server - Model Cxx
- ▶ 7208-012 5.0 GB 8 mm cartridge tape unit
- ▶ 7208-222 7.0 GB 8 mm cartridge tape unit
- ▶ 7208-232 8 mm Dual 5.0 GB cartridge tape subsystem
 - #0501 counts as one 7208
 - #0502 counts as two 7208
 - Counts as two 7208s
- ▶ 7208-342 20.0 GB 8 mm Cartridge Tape Bridge Box
- ▶ 9348-00x ½-inch Reel Tape Unit - Rack Mount
- ▶ 9427-2108 8 mm Library Attach

Use the #5702 PCI-X Ultra Tape Controller to attach tape devices with LVD connections.

Minimum operating system level: OS/400 V4R5

Supported on Models 270, 9406 520, 550, 570, 595, 800, 810, 820, 825, 830, 840, 870, 890, SB2, and SB3.

The #2749 is a Customer Install Feature.

The #2749 is withdrawn from marketing as of 03 March 2005.

#2757	<p>#2757 PCI-X Ultra RAID Disk Controller</p> <p>The #2757 PCI-X Ultra RAID Disk Controller is an Ultra SCSI controller with a maximum write cache size of 235 MB (757 MB compressed) that provides RAID-5 protection for internal disks and also supports internal tape units, CD-ROM, and DVD units. The #2757 has four Ultra4 SCSI buses.</p> <p>In addition to providing RAID-5 protection for disks, the #2757 PCI-X Ultra RAID Disk Controller is designed to work as a high performance controller for disks protected by system mirroring or disks with no protection.</p> <p>The #2757 PCI-X Ultra RAID Disk Controller supports a maximum of 20 disk units. A minimum of three disk units of the same capacity are needed for a valid RAID-5 configuration. A maximum of six arrays are allowed per controller, with a maximum of 18 disk units allowed per array. All disk units in an array must be of the same capacity. Parity is spread across either 2, 4, 8, or 16 disk units in an array. If an array of three disk units is started, parity is spread across two disk units. If an array of four to seven disk units is started, parity is spread across four disk units. If an array of 8-15 disk units is started, parity is spread across eight disk units. If an array of 16-18 disk units is started, parity is spread across 16 disk units.</p> <p><i>Availability</i> is the number of arrays and size of each array can be influenced by specifying an optimization of either <i>Balance</i>, <i>Performance</i>, or <i>Capacity</i> in iSeries Navigator when starting arrays. An optimization of <i>Balance</i> is used by default when starting arrays from DST or SST options. If disk units are included into an existing array, parity can be spread across less than the preferred number of disk units. In this case, the RAID function must be stopped and then started to redistribute the parity.</p> <p>The #2757 controls up to two removable media devices (internal tape, CD-ROM, and DVD). The #2757 does not support DASD compression.</p> <p>Due to system unit and system unit expansion disk unit cage SCSI bus designs, only the Models 800 and 810 have a suitable system configuration to allow 18 disk units to attach to a single #2757. All other system unit or tower disk configurations restrict the number of attaching disk units to 15 or less. Requires a #7137 DASD Concurrent Maintenance Cage for the Model 800.</p> <p>Minimum operating system level: OS/400 V5R2 Supported on Models 270, 520, 550, 570, 595, 800, 810, 820, 825, 830, 840, 870, 890, and 9411-100. The #2757 is a Customer Install Feature.</p>
#2763	<p>#2763 PCI RAID Disk Unit Controller</p> <p>The #2763 is an Ultra2 SCSI controller with a 10 MB write-cache that provides RAID-5 protection for internal disk units and supports up to two removable media devices (internal tape units and CD-ROM units). In addition to providing RAID-5 protection for disks, the #2763 is also designed to work as a high performance controller for disks protected by system mirroring or disks with no protection. The #2763 controller supports a maximum of 12 disk units and is only supported on the Model 820, #5075 PCI Expansion Tower, and supported on the #0595/#5095.</p> <p>A minimum of four disk units of the same capacity are needed for a valid RAID-5 configuration. A maximum of three arrays are allowed per controller, with a maximum of 10 disk units allowed per one array. All disk units in an array must be of the same capacity. Parity is spread across four disk units for arrays of four to 10. The #2763 does not support hardware disk compression. The #2763 does not support the #4331 1.6 GB Read Cache Device.</p> <p>The #2763 can be directly attached to a Linux partition. When ordered as #0604 - Direct Attach #2763 PCI RAID Disk Unit Controller, an IOP is not required. When directly attached to a Linux partition, the #2763 cannot be accessed by OS/400 partitions. When directly attached to a Linux partition, the #2763 does not support RAID or hardware disk compression.</p> <p>Requires a long PCI card slot.</p> <p>Minimum operating system level: OS/400 V4R5 Supported on Models 250, 270, 9406 520, 550, 570, 595, 810, 820, 825, 830, 840, 870, 890, and 9411-100. The #2763 is a Customer Install Feature. The #2763 is withdrawn from marketing as of 21 November 2003 for new orders. Conversions to feature #2763 remain available. A #5703 PCI-X RAID Disk Unit Controller is the recommended replacement.</p>

#2765	<p>#2765 PCI Fibre Channel Tape Controller</p> <p>The #2765 PCI Fibre Channel Tape Controller provides Fibre Channel attachment capability for external tape devices. The #2765 supports point-to-point and arbitrated loop topologies and has an LC type cable connector. Each #2765 is shipped with a wrap connector (P/N 05N6767).</p> <p>The devices supported for Fibre Channel attachment are:</p> <ul style="list-style-type: none"> ▶ 3534-1RU SAN Fibre Channel Managed Hub (1 Gbps) ▶ Fibre Channel Switches: <ul style="list-style-type: none"> – 2031-224 McDATA Sphereon 4500 Fabric Switch – 2031-232 McDATA Sphereon 3232 Fabric Switch – 2109 S08/S16 (1 Gbps) – 2109 F16 (2 Gbps) – 3534 F08 (2 Gbps) ▶ SAN Fabric Directors: <ul style="list-style-type: none"> – 2032-064 McDATA Intrepid 6064 Enterprise Fibre Channel Director – 2032-140 McDATA Intrepid 6140 Director ▶ 3582-L23 Ultrium Tape Library ▶ 3583-Lxx Ultrium Scalable Tape Library ▶ 3584-L32 or D32 Ultra scalable Tape Library ▶ 3590 ½-inch Cartridge Tape Subsystem Models E11, E1A, H11, and H1A ▶ 3592 Enterprise Tape Drive <p>A #0163 Fibre Channel Attach Specify code is required for each device attaching to an iSeries server via a #2765. The following adapter kits are required when connecting SC-type cables to the #2765:</p> <ul style="list-style-type: none"> ▶ #0371 - LC-SC Adapter Kit (50um) can be ordered on initial, model upgrade, and simple MES orders. This optional kit is used to attach SC- type Fibre (50 micron) cables to a #2765. This kit contains a 2m LC-ST cable and ST-SC adapter for 50 micron Fibre. ▶ #0372 - LC-SC Adapter Kit (62.5um) can be ordered on initial, model upgrade, and simple MES orders. This optional kit is used to attach SC-type Fibre (62.5 micron) cables to a #2765. This kit contains a 2m LC-ST cable and ST- SC adapter for 62.5 micron Fibre. <p>The #2765 can be directly attached to a Linux or AIX partition. When ordered as #0611 - Direct Attach #2765 PCI Fibre Channel Tape Controller, an IOP is not required. When directly attached to a Linux/AIX partition, the #2765 cannot be accessed by i5/OS partitions.</p> <p>An optics cleaning kit (P/N 46G6844) and instruction sheet (P/N 21P6238, form number SY27-2604) are supplied, one per system, when a #2765/#2766 is ordered.</p> <p>Multi-target support with a maximum of 16 targets with OS/400 V5R2.</p> <p>The #2765 does not support the Alternate IPL device function. A D-mode IPL is required using CD-ROM, DVD-ROM, or another alternate IPL tape device. Then select a #2765 to complete the installation or recovery process.</p> <p>Minimum operating system level: OS/400 V5R1 Supported on Models 270, 9406 520, 550, 570, 595, 800, 810, 820, 825, 830, 840, 870, 890, and 9411-100. The #2765 is a Customer Install Feature. The #2765 is withdrawn from marketing as of 01 October 2004. A #5704 is the recommended replacement.</p>
-------	--

<p>#2766</p>	<p>#2766 PCI Fibre Channel Disk Controller</p> <p>The #2766 provides Fibre Channel attachment capability for external disk devices. The #2766 supports point-to-point and arbitrated loop topologies and has an LC type cable connector. Each #2766 is shipped with a wrap connector (P/N 05N6767).</p> <p>The following devices are supported by the #2766:</p> <ul style="list-style-type: none"> ▶ 2105-F10/F20/800 IBM TotalStorage® Enterprise Storage Server® ▶ 3534-1RU SAN Fibre Channel Managed Hub (1 Gbps) ▶ Fibre Channel Switches: <ul style="list-style-type: none"> – 2031-224 McDATA Sphereon 4500 Fabric Switch – 2031-232 McDATA Sphereon 3232 Fabric Switch – 2109 S08/S16 (1 Gbps) – 2109 F16 (2 Gbps) – 3534 F08 (2 Gbps) ▶ SAN Fabric Directors: <ul style="list-style-type: none"> – 2032-064 McDATA Intrepid 6064 Enterprise Fibre Channel Director – 2032-140 McDATA Intrepid 6140 Director <p>The following adapter kits are required when connecting SC type cables to the #2766:</p> <ul style="list-style-type: none"> ▶ #0371 - LC-SC Adapter Kit (50 micron) optional kit is used to attach SC-type Fibre (50 micron) cables to a #2766. The #0371 kit contains a 2m LC-ST cable and ST-SC adapter for 50 micron Fibre. ▶ #0372 - LC-SC Adapter Kit (62.5 micron) optional kit is used to attach SC-type Fibre (62.5 micron) cables to a #2766. The #0372 kit contains a 2m LC-ST cable and ST-SC adapter for 62.5 micron Fibre. <p>An optics cleaning kit (P/N 46G6844) and instruction sheet (P/N 21P6238, form number SY27-2604) are supplied, one per system, when a #2765/#2766 is present or ordered.</p> <p>The #2766 requires a dedicated IOP. No other IOA is allowed on an IOP with the #2766.</p> <p>The #2766 can be directly attached to a Linux partition. When ordered as #0612 - Direct Attach #2766 PCI Fibre Channel Disk Controller, an IOP is not required. When directly attached to a Linux partition, the #2766 cannot be accessed by OS/400 partitions.</p> <p>Clients must supply all Fibre Channel cables for the #2766. See the “Hard rules: iSeries IOA capabilities” topic in <i>PCI and PCI-X Placement Rules for IBM System i5, eServer i5, and iSeries servers with i5/OS V5R4 and V5R3</i>, REDP-4011, or <i>PCI Card Placement Rules for the IBM @server iSeries Server OS/400 Version 5 Release 2: September 2003</i>, REDP-3638, for OS/400 V5R2 or earlier releases, for additional restrictions.</p> <p>Multi target support with a maximum of 32 targets is supported with OS/400 V5R2.</p> <p>Minimum operating system level: OS/400 V5R1 Supported on Models 270, 9406 520, 550, 570, 595, 800, 810, 820, 825, 830, 840, 870, 890, and 9411-100. The #2766 is a Customer Install Feature.</p>
<p>#2768</p>	<p>#2768 PCI Magnetic Media Controller</p> <p>The #2768 PCI Magnetic Media Controller provides Ultra SCSI attachment capability for an external tape or an external CD-ROM device that has a Single Ended SCSI interface. The #2768 has one HD68 connector/port.</p> <p>The #2768 supports a minimum of one of the following devices:</p> <ul style="list-style-type: none"> ▶ 7206-VX2 80 GB VXA-2 External Tape Drive ▶ 7207-122 QIC-SLR Tape Bridge Box (4 GB External ¼-inch Cartridge Tape Drive) ▶ 7208-345 60 GB External 8 mm Tape Drive ▶ 7329-308 SLR100 ¼-inch Tape Autoloader ▶ 7210-020 CD-ROM Bridge Box ▶ 7210-025 DVD-RAM Drive <p>See 7.6, “Device cabling rules for #5702, #5705, #5712, #5715, #2718, and #2768 PCI Magnetic Media Controller” on page 300, for information about connecting devices to the #2768, including daisy-chaining options.</p> <p>Minimum operating system level: to support the 7329-308 and 7208-345: OS/400 V4R5 Minimum operating system level: to support the 7206-VX2, 7210-020, and 7210-025: OS/400 V5R1 Supported on Models 810, 825, 870, and 890. The #2768 is a Customer Install Feature. The #2768 is withdrawn from marketing as of 01 October 2004. A #5712 PCI-X Tape/DASD Controller is the recommended replacement.</p>

#2780	<p>#2780 PCI-X Ultra4 RAID Disk Controller</p> <p>The #2780 PCI-X Ultra4 RAID Disk Controller is an Ultra4 (u320) SCSI controller with a maximum compressed write cache size of 757 MB and maximum compressed read cache of one GB. The #2780 provides RAID-5 protection for internal disks and also supports internal tape units, CD-ROM, and DVD units. The #2780 has four Ultra4 SCSI buses. In addition to providing RAID-5 protection for disks, the #2780 PCI-X Ultra4 RAID Disk Controller is designed to work as a high performance controller for disks protected by system mirroring or disks with no protection.</p> <p>The #2780 PCI-X Ultra4 RAID Disk Controller supports a maximum of 20 disk units. A minimum of three disk units of the same capacity are needed for a valid RAID-5 configuration. A maximum of six arrays are allowed per controller, with a maximum of 18 disk units allowed per array.</p> <p>All disk units in an array must be of the same capacity. Parity is spread across either two, four, eight, or 16 disk units in an array. If an array of three disk units is started, parity is spread across two disk units. If an array of four to seven disk units is started, parity is spread across four disk units. If an array of 8-15 disk units is started, parity is spread across eight disk units. If an array of 16-18 disk units is started, parity is spread across 16 disk units.</p> <p>The number of arrays and size of each array can be influenced by specifying an optimization of either <i>Balance</i>, <i>Performance</i>, or <i>Capacity</i> when starting arrays in iSeries Navigator. An optimization of <i>Balance</i> is used by default when starting arrays from DST or SST options. If disk units are included into an existing array, the number of parity drives does not increase, so parity can be spread across less than the preferred number of disk units. In this case, the RAID function must be stopped and then started in order to redistribute the parity.</p> <p>The #2780 controls up to two removable media devices (internal tape, CD-ROM, and DVD). The #2780 does not support DASD compression. The #2780 has a battery that provides concurrent maintenance and improved resiliency.</p> <p>The #2780 can be directly attached to a Linux or AIX partition. When ordered as #0627 - Direct Attach #2780 PCI-X Ultra4 RAID Disk Controller, an IOP is not required. When directly attached to a Linux or AIX partition, the #2780 cannot be accessed by OS/400 partitions.</p> <p>Requires one 3V long PCI slot. A #7137 DASD Concurrent Maintenance Cage is required for the Model 800.</p> <p>Placement rules:</p> <ul style="list-style-type: none"> ▶ Not supported in Slot 1 of #5074, #5079, #5094, and #5294. ▶ Due to system unit and external tower disk unit cage SCSI bus designs, only the Models 270, 800 and 810 have a suitable system configuration to allow 18 disk units to attach to a single #2780. All other system unit or tower disk configurations restrict the number of attaching disk units to 15 or less. ▶ Further restrictions apply when a MES Conversion #0299 to add an Auxiliary Write Cache is made. The card providing the write cache attaches to a #2780 on one of the Ultra4 SCSI buses, thus reducing the available SCSI busses to attach disk drives by one. ▶ SCSI port 1 is used to connect to the removable media slots in the Model 825. ▶ SCSI port 1 can support LVD or single-ended devices. ▶ SCSI ports 0, 2 and 3 are LVD only. <p>Minimum operating system level: SUSE Linux Enterprise Server 9 for POWER or Red Hat Enterprise Linux AS for POWER Version 3 or OS/400 V5R2 Supported in Models 520, 550, 570, 595, 800, 810, 820, 825, 830, 840, 870, and 890. The #2780 is a Customer Install Feature. Since July 2005 the #2780 can only be ordered if system has mirrored protection (#0040 prerequisite). Order #0299 MES Conversion to improve cache data redundancy when system has RAID protection.</p>
-------	--

#2782	<p>#2782 PCI-X RAID Disk Unit Controller</p> <p>The #2782 PCI-X RAID Disk Unit Controller is a PCI-X SCSI controller with a 40 MB cache that provides RAID-5 protection for internal disks and also supports internal tape units, CD-ROM and DVD devices. The #2782 has two SCSI buses that support up to 12 disk units. Hardware data compression is not supported.</p> <p>In addition to providing RAID-5 protection for disks, #2782 also works as a high-performance controller for disks protected by system mirroring, or disks with no protection. In the RAID-5 configuration, disk unit protection is provided at less cost than mirroring, and with better performance than system checksums.</p> <p>A minimum of three disk units of the same capacity are needed for a valid RAID-5 configuration. A maximum of four arrays are allowed per controller, with a maximum of 12 disk units allowed per array. All disk units in an array must be of the same capacity.</p> <p>Parity is spread across either two, four, or eight disk units in an array. If an array of three disk units is started, parity is spread across two disk units. If an array of four to seven disk units is started, parity is spread across four disk units. If an array of eight to twelve disk units is started, parity is spread across eight disk units.</p> <p>The number of arrays and size of each array can be influenced by specifying an optimization of either Balance, Performance, or Capacity when starting arrays in iSeries Navigator. An optimization of Balance is used by default when starting arrays from the DST or SST options. If disk units are included into an existing array, parity can be spread across less than the preferred number of disk units. In this case the RAID function must be stopped and then started in order to redistribute the parity.</p> <p>The #2782 controls up to two removable media devices (internal tape, CD-ROM and DVD). The #2782 PCI-X RAID Disk Unit Controller does not support hardware data compression. The #2782 does not support the attachment of external devices.</p> <p>Minimum operating system level: OS/400 V5R2 Supported on Models 270, 9406 520, 550, 570, 595, 800, 810, 820, 825, 830, 840, 870, 890 and 9411-100. The #2782 is a Customer Install Feature. The #2782 is withdrawn from marketing as of 01 January 2004. A #5703 PCI-X RAID Disk Unit Controller is the recommended replacement.</p>
#2787	<p>#2787 PCI-X Fibre Channel Disk Controller</p> <p>The #2787 PCI-X Fibre Channel Disk Controller provides Fibre Channel attachment capability for external disk devices. The #2787 supports point-to-point and arbitrated loop topologies and has an LC-type cable connector. Each #2787 is shipped with a wrap connector (part number 05N6767). It supports 64-bit, 133 MHz PCI-X bus speeds. It is the PCI-X replacement card for the #2766 PCI Fibre Channel Disk Controller.</p> <p>The following adapter kits are required when connecting SC-type cables to the #2787:</p> <ul style="list-style-type: none"> ▶ #0371 - LC-SC Adapter Kit (50um) can be ordered, both on initial, model upgrades, and simple MES orders. This optional kit is used to attach SC-type fibre (50 micron) cables to a #2787. The #0371 kit contains a 2m LC-ST cable and ST-SC adapter for 50 micron fiber cable. ▶ #0372 - LC-SC Adapter Kit (62.5um) can be ordered, both on initial, model upgrades, and simple MES orders. This optional kit is used to attach SC-type fiber (62.5 micron) cables to a #2787. The #0372 kit contains a 2m LC-ST cable and ST-SC adapter for 62.5 micron fiber cable. <p>An optics cleaning kit (part number 46G6844) and instruction sheet (part number 21P6238, form number SY27-2604) is supplied, one per system, when a #2787 is ordered.</p> <p>When used as a direct attached adapter for Linux, the #0626 - Direct Attach #2787 PCI-X Fibre Channel Disk Controller should be ordered in place of the #2787.</p> <p>Maximum physical quantities are determined by requiring a dedicated IOP and limited to two per Multi-adapter Bridge boundary.</p> <p>All Fibre Channel cables required for the #2787 PCI-X Fibre Channel Disk Controller are supplied by the client.</p> <p>Minimum operating system level: OS/400 V5R2 Supported on Models 270, 520, 550, 570, 595, 800, 810, 820, 825, 830, 840, 870, 890, and 9411-100. The #2787 is a Customer Install Feature.</p>

<p>#4748 #9748</p>	<p>#4748 PCI RAID Disk Unit Controller</p> <p>The #4748/#9748 is an Ultra2 SCSI controller with a 26 MB write-cache that provides RAID-5 protection and compression for internal disk units and supports internal tape units and CD-ROM units.</p> <p>The #4748/#9748 supports both compression and non-compression modes. The mode of operation is determined by a hardware jumper. The #4748/#9748 is shipped in non-compression mode. By moving the hardware jumper, the controller functions in compression mode.</p> <p>In addition to providing RAID-5 protection for disks, the #4748/#9748 is also designed to work as a high performance controller for disks protected by system mirroring or disks with no protection. The #4748 also supports #4331 1.6 GB Read Cache Device, which provides increased performance. The #4331 1.6 GB Read Cache Device is supported only when #4748/#9748 is <i>not</i> in compression mode.</p> <p>The #4748 does not support data compression on 35 GB or larger disk units. The #4748 controller supports a maximum of 15 disk units. The #9748 is the base disk controller for Models 830 and 840.</p> <p>A minimum of four disk units of the same capacity are needed for a valid RAID-5 configuration. A maximum of four arrays are allowed per controller, with a maximum of 10 disk units allowed per array. All disk units in an array must be of the same capacity. Parity is spread across four disk units for arrays of four to seven disk units. Parity can be spread across either four or eight disk units for arrays of 8 to 10 disk units. For systems started with 8 to 10 disk units in an array, the parity for that array is spread across eight disk units. For systems that are started with less than eight disk units in an array and later MES upgraded to 8, 9, or 10 disk units, the RAID function must be stopped and then started before the parity is spread across eight disk units.</p> <p>The #4748/#9748 controls up to two removable media devices (internal tape or CD-ROM). The #4748 can be directly attached to a Linux partition. When installed as #0605 - Direct Attach #4748 PCI RAID Disk Unit Controller, an IOP is not required. When directly attached to a Linux partition, the #4748 cannot be accessed by OS/400 partitions. When directly attached to a Linux partition, the #4748 does not support RAID or hardware disk compression.</p> <p>Requires a long PCI card slot.</p> <p>Minimum operating system level: OS/400 V4R5 Supported on Models 270, 520, 550, 570, 595, 800, 810, 820, 825, 830, 840, 870, 890, and 9411-100. The #4748 and #9748 are Customer Install Features. The #4748 and #9748 are withdrawn from marketing as of 02 July 2002. A #2757 PCI-X Ultra RAID Disk Controller is the recommended replacement.</p>
------------------------	--

<p>#4778 #9778</p>	<p>#4778 PCI RAID Disk Unit Controller</p> <p>The #4778/#9778 is an Ultra2 SCSI controller with a maximum compressed write cache size of 104 MB that provides RAID-5 protection and compression for internal disk units and supports internal tape units, CD-ROM and DVD-RAM units. The #4778 does not support data compression on 70 GB or larger disk units.</p> <p>The #4778/#9778 supports both disk compression and enhanced modes. The mode of operation is determined by a hardware jumper. The #4778/#9778 is shipped in enhanced mode, which enables compression of the write cache and Extended Adaptive Cache. A Read Cache Device is needed for Extended Adaptive Cache. By moving the hardware jumper, the controller functions in disk compression mode. Disk compression mode should only be used when disk compression is desired.</p> <p>In addition to providing RAID-5 protection for disks, #4778/#9778 is also designed to work as a high performance controller for disks protected by system mirroring or disks with no protection. In the RAID-5 configuration, disk unit protection is provided at less cost than mirroring, and with better performance than system checksum.</p> <p>The #4778/#9778 also supports the #4331 1.6 GB Read Cache Device, which is used by Extended Adaptive Cache to provide increased performance. The #4331 1.6 GB Read Cache Device is supported only when the #4778/#9778 is in enhanced mode. The #4778/#9778 controller supports a maximum of 18 disk units.</p> <p>A minimum of four disk units of the same capacity are needed for a valid RAID-5 configuration. A maximum of four arrays are allowed per controller, with a maximum of 10 disk units allowed per array. All disk units in an array must be of the same capacity. Parity is spread across 4 disk units for arrays of 4 to 7 disk units. Parity can be spread across either 4 or 8 disk units for arrays of 8 to 10 disk units. For systems started with 8 to 10 disk units in an array the parity, for that array, is spread across eight disk units. For systems that are started with less than eight disk units in an array and later MES upgraded to 8, 9, or 10 disk units, the RAID function must be stopped and then started before the parity is spread across eight disk units.</p> <p>The #4778/#9778 controls up to two removable media devices (internal tape, CD-ROM or DVD-RAM). Due to system unit and external tower disk unit cage SCSI bus designs, only the Model 800 and 810 have a suitable system configuration to allow 18 disk units to attach to a single #4778. All other system unit and tower disk unit configurations restrict the number of attaching disk units to 15 or less.</p> <p>The #4778 can be directly attached to a Linux partition. When ordered as #0606 - Direct Attach #4778 PCI RAID Disk Unit Controller, an IOP is not required. When directly attached to a Linux partition, the #4778 cannot be accessed by OS/400 partitions. When directly attached to a Linux partition, the #4778 does not support RAID or hardware disk compression. Minimum operating system level: OS/400 V5R1 The #4778 is a Customer Install Feature. The #4778 is withdrawn from marketing as of 19 November 2004. Conversions to the #4778 remain available.</p>
<p>#5580</p>	<p>#5580 - 2780 Ctlr w/Aux Write Cache</p> <p>The #5580 provides a disk controller with auxiliary write cache to improve cache data redundancy. The #5580 includes a #2780 PCI-X Ultra4 RAID Disk Controller and a secondary IOA with 757 MB of auxiliary maximum compressed write cache.</p> <p>The #2780 and the secondary IOA each require one PCI-X slot and must be installed together in the same system unit or I/O unit/drawer/tower. The #2780 and the auxiliary write cache IOA are connected by a SCSI cable (provided). Feature #2780 does not appear on IBM ordering, shipping, or inventory documentation.</p> <p>The connecting SCSI cable is attached to port four of the #2780, reducing the number of SCSI buses that support disk drives from four to three. The reduction of SCSI buses can also reduce the number of disk drives supported by the #2780, depending on the system or I/O unit/drawer/tower in which the #2780 is installed. No disk drives are driven by the auxiliary write cache IOA.</p> <p>Minimum operating system level: OS/400 V5R2 with CUM C5123520 and prerequisite PTFs, or i5/OS V5R3 with cumulative PTF package C5102530 and prerequisite PTFs. Supported on Models 270, 520, 550, 570, 595, 800, 810, 820, 830, 840, 870, 890, and 9411-100.</p>

#5581	<p>#5581 - 2757 Ctlr w/Aux Write Cache</p> <p>The #5581 provides a disk controller with auxiliary write cache to improve cache data redundancy. The #5581 includes a #2757 PCI-X Ultra4 RAID Disk Controller and a secondary IOA with 757 MB of auxiliary maximum compressed write cache. The #2757 and the secondary IOA each require one PCI-X slot and must be installed together in the same system unit or I/O unit/drawer/tower. The #2757 and the auxiliary write cache IOA are connected by a SCSI cable (provided). Feature #2757 does not appear on IBM ordering, shipping, or inventory documentation.</p> <p>The connecting SCSI cable is attached to port four of the #2757, reducing the number of SCSI buses that support disk drives from four to three. The reduction of SCSI buses can also reduce the number of disk drives supported by the #2757, depending on the system or I/O unit/drawer/tower in which the #2757 is installed. No disk drives are driven by the auxiliary write cache IOA.</p> <p>Minimum operating system level: OS/400 V5R2 with cumulative PTF package C5123520 and prerequisite PTFs, or i5/OS V5R3 with cumulative C5102530 and prerequisite PTFs. Supported on Models 270, 520, 550, 570, 595, 800, 810, 820, 830, 840, 870, 890, and 9411-100.</p>
#5702	<p>#5702 PCI-X Ultra Tape Controller (VHDCI)</p> <p>The #5702 PCI-X Ultra Tape Controller provides a SCSI Ultra PCI attachment capability for external tape devices and removable media devices.</p> <p>The #5702 has two ports that can attach two external tape devices. Each port can support at a minimum one of the following devices:</p> <ul style="list-style-type: none"> ▶ 3580-L23 IBM TotalStorage Ultrium 2 Tape Drive ▶ 3581-L28 IBM Ultrium 2 Tape Drive ▶ 3582-L23 IBM Ultrium Tape Library LVD Ultrium2 drive feature ▶ 3583-Lxx IBM Ultrium Scalable Tape Library, LVD Ultrium 2 drive feature ▶ 3584 Ultra Scalable Tape Library, LVD Ultrium 2 drive feature ▶ 3584-L32 or D32 Ultra Scalable Tape Library, LVD Ultrium2 ▶ 7206-VX2 80 GB VXA-2 External Tape Drive ▶ 7207-122 QIC-SLR Tape Bridge Box (4 GB External ¼-inch Cartridge Tape Drive) ▶ 7208-345 60 GB External 8 mm Tape Drive ▶ 7210-020 External CD-ROM ▶ 7210-025 External DVD-RAM ▶ 7329-308 SLR100 ¼-inch Tape Autoloader <p>The #5702 can be directly attached to a Linux partition. When ordered as #0624 - Direct Attach #5702 PCI-X Ultra Tape Controller, an IOP is not required. When directly attached to a Linux partition, the #5702 cannot be accessed by OS/400 partitions.</p> <p>A #5702 running in an i5OS or OS/400 partition cannot drive internal disk units in any expansion tower, base I/O tower, or system unit enclosure. See 7.6, "Device cabling rules for #5702, #5705, #5712, #5715, #2718, and #2768 PCI Magnetic Media Controller" on page 300, for information about connecting devices to the #5702 including daisy-chaining options.</p> <p>Minimum operating system level: OS/400 V5R2 Supported on Models 520 (9406 only), 550, 570, 595, and 9411-100. The #5702 is a Customer Install Feature.</p> <p>The #5702 is withdrawn from marketing as of 01 June 2006. A #5712 PCI-X Tape/DASD Controller is the recommended replacement. Otherwise, a #5766 for IOP based tape attachment, or a #5736 IOP based with #0290 - External Tape Attached Placement Code are the recommended replacements. For IOP-less tape attachment use a #5775 with #0290 - External Tape Attached Placement Code.</p>

#5703	<p>#5703 PCI-X RAID Disk Unit Controller</p> <p>The #5703 PCI-X RAID Disk Unit Controller is an Ultra3 SCSI controller with a cache size of 40 MB that provides RAID-5 protection for internal disks and internal tape units, CD-ROM, DVD-RAM and DVD-ROM units. The #5703 has two Ultra3 SCSI buses. In addition to providing RAID-5 protection for disks, the #5703 is designed to work as a high performance controller for disks protected by system mirroring or disks with no protection. In the RAID-5 configuration, disk unit protection is provided at less cost than mirroring, and with better performance than system checksum.</p> <p>The #5703 controller supports a maximum of 12 disk units. When used in a Model 520, The #5703 controls disks in the #6584 4 Disk Slot Exp - PCI-X Controller.</p> <p>Due to a system unit and external tower disk unit cage SCSI bus designs, only the 270, 800 and 810 Models, and the #0595/#5095 PCI-X Expansion Tower have a suitable system configuration to allow 12 disk units to attach to a single #5703. All other system unit and tower disk configurations restrict the number of attaching disk units to 10 or less.</p> <p>A minimum of three disk units of the same capacity are needed for a valid RAID-5 configuration. A maximum of four arrays are allowed per controller, with a maximum of 12 disk units allowed per array. All disk units in an array must be of the same capacity. Parity is spread across either two, four, or eight disk units in an array. If an array of three disk units is started, parity is spread across two disk units. If an array of four to seven disk units is started, parity is spread across four disk units. If an array of 8-12 disk units is started, parity is spread across eight disk units.</p> <p>The number of arrays and size of each array can be influenced by specifying an optimization of either <i>Balance</i>, <i>Performance</i>, or <i>Capacity</i> in Operations Navigator when starting arrays. An optimization of <i>Balance</i> is used by default when starting arrays from the green screens. If disk units are included into an existing array, parity can be spread across fewer than the preferred number of disk units. In this case the RAID function must be stopped and then started to redistribute the parity.</p> <p>The #5703 controls up to two removable media devices (internal tape, CD-ROM, DVD-RAM, DVD-ROM). The #5703 does not support the attachment of external devices. A #5703 is the recommended replacement for the #2782 PCI-X RAID Disk Unit Controller. When ordered as #0628 - Direct Attach #5703 PCI-X RAID Disk Unit Controller, an IOP is not required. When directly attached to a Linux/AIX partition, the #5703 cannot be accessed by OS/400 partitions.</p> <p>Minimum operating system level: OS/400 V5R2 Supported on Models 520, 550, 570, 595, 270, 800, 810, 820, 825, 830, 840, 870, 890, and 9411-100. The #5703 is a Customer Install Feature. A #5735 IOP based disk attachment, #5776 IOP-less disk attachment, or #0648 are the recommended replacements.</p>
#5704	<p>#5704 PCI-X Fibre Channel Tape Controller</p> <p>The #5704 PCI-X Fibre Channel Tape Controller provides Fibre Channel attachment capability for external tape devices. The #5704 supports point-to-point and arbitrated loop topologies and has an LC-type cable connector. Each #5704 is shipped with a wrap connector (part number 05N6767). The #5704 supports 64-bit, 133 MHz PCI-X bus speeds. It is the PCI-X card replacement for the #2765 PCI Fibre Channel Tape Controller.</p> <p>All Fibre Channel cables required for the #5704 are supplied by the client.</p> <p>Supported devices include:</p> <ul style="list-style-type: none"> ▶ 3582-L23 Ultrium Tape Library ▶ 3583-Lxx Ultrium Scalable Tape Library ▶ 3584-L32 or D32 Ultra scalable Tape Library ▶ 3590 ½-inch Cartridge Tape Subsystem Models E11, E1A, H11, and H1A ▶ 3592 Enterprise Tape Drive <p>The #5704 does not support the Alternate IPL device function. A D-mode IPL is required using CD-ROM, DVD-ROM, or another alternate IPL tape device. Then select a #5704 to complete the installation or recovery process.</p> <p>Minimum operating system level: OS/400 V5R2 Supported on Models 270, 520, 550, 570, 595, 800, 810, 820, 825, 830, 840, 870, 890, SB2, SB3, and 9411-100. The #5704 is a Customer Install Feature.</p>

#5705	<p>#5705 PCI-X Tape/DASD Controller</p> <p>The #5705 PCI-X Tape/DASD Controller provides SCSI Ultra4 PCI attachment capability for external tape devices, external removable media devices, and internal DASD devices. There are two SCSI buses on each #5705. Each SCSI bus has both an internal port and an external port for a total of four ports on the card. Each SCSI bus can have only one attachment, either internal or external. Attaching internal and external devices to the same SCSI bus causes the internal device to become disabled.</p> <p>The internal SCSI port supports up to six disk units, but does not support RAID. If two external SCSI ports are required, a #5702 should be ordered.</p> <p>The external port can support the following devices:</p> <ul style="list-style-type: none"> ▶ 3580-L23 IBM TotalStorage Ultrium 2 Tape Drive ▶ 3581-L28 IBM Ultrium 2 Tape Drive ▶ 3582-L23 IBM Ultrium Tape Library LVD Ultrium2 drive feature ▶ 3583-Lxx IBM Ultrium Scalable Tape Library, LVD Ultrium 2 drive feature ▶ 3584 Ultra Scalable Tape Library, LVD Ultrium 2 drive feature ▶ 3584-L32 or D32 Ultra Scalable Tape Library, LVD Ultrium2 ▶ 7206-VX2 80 GB VXA-2 External Tape Drive ▶ 7207-122 QIC-SLR Tape Bridge Box (4 GB External ¼-inch Cartridge Tape Drive) ▶ 7208-345 60 GB External 8 mm Tape Drive ▶ 7210-020 External CD-ROM ▶ 7210-025 External DVD-RAM ▶ 7329-308 SLR100 ¼-inch Tape Autoloader <p>See 7.6, “Device cabling rules for #5702, #5705, #5712, #5715, #2718, and #2768 PCI Magnetic Media Controller” on page 300, for information about connecting devices to the #5705 including daisy-chaining options.</p> <p>Minimum operating system level: OS/400 V5R2 Refer to Informational APAR II13440 at: http://www-03.ibm.com/servers/eserver/support/series/index.html Supported on Models 800 and 810. The #5705 is a Customer Install Feature. The #5705 is withdrawn from marketing as of 01 June 2006. A #5736 for IOP-less disk attachment, or #5775 for IOP-less disk attachment are the recommended replacements.</p>
#5709	<p>#5709 RAID Enabler Card</p> <p>The #5709 RAID Enabler Card is an optional SCSI RAID controller with a 16 MB write cache. The #5709 supports up to eight disk unit positions in the Model 520 system unit and up to six disk unit positions in the Model 570 system unit. The #5709 plugs into its own specific internal slot and does not require/use a PCI card slot.</p> <p>In the Model 520, the #5709 can be used with or without a #6574 - 4-Disk Slot Expansion Base Controller. When installed without a #6574 4-pack disk backplane, the #5709 allows disk units plugged into the base 4-pack disk backplane to be in a RAID array (minimum of three disk units for an array). For the Model 520, when a #5709 is installed, the base integrated non-RAID SCSI disk controller is deactivated.</p> <p>The #5709 is a required feature for the Model 570 system units.</p> <p>The i5/OS operating system does not have the capability to interface directly to the embedded SCSI controller. The #5709 communicates solely with the embedded controller. An IOP must be present for the #5709 to communicate with the i5/OS operating system.</p> <p>Minimum operating system level: i5/OS V5R3 Supported in Linux and AIX partitions with SUSE Linux Enterprise Server 9 for POWER or Red Hat Enterprise Linux AS for POWER Version 3, and AIX 5L for POWER V5.2. Supported on Models 520, 550, and 570. The #5709 is a Customer Install Feature. The #5709 is withdrawn from marketing in 2005 for the Model 570. A #5726 is the recommended replacement for the Model 570. A #5728 is the recommended replacement when upgrading to Model 570+.</p>
#5710	<p>#5710 PCI-X Dual Channel Ultra 320 SCSI Blind Swap Adapter (LVD)</p> <p>Supported in a Linux partition.</p>

<p>#5712</p>	<p>#5712 PCI-X Tape/DASD Controller (LVD) The #5712 PCI-X Tape/DASD Controller provides a SCSI Ultra PCI attachment capability for external tape devices and removable media devices.</p> <p>The #5712 has two ports that can attach two external tape devices. Each port can support at a minimum one of the following devices:</p> <ul style="list-style-type: none"> ▶ 3580-L23 IBM TotalStorage Ultrium 2 Tape Drive ▶ 3581-L28 IBM Ultrium 2 Tape Drive ▶ 3582-L23 IBM Ultrium Tape Library LVD Ultrium2 drive feature ▶ 3583-Lxx IBM Ultrium Scalable Tape Library, LVD Ultrium 2 drive feature ▶ 3584 Ultra Scalable Tape Library, LVD Ultrium 2 drive feature ▶ 3584-L32 or D32 Ultra Scalable Tape Library, LVD Ultrium2 ▶ 7206-VX2 80 GB VXA-2 External Tape Drive ▶ 7207-122 QIC-SLR Tape Bridge Box (4 GB External ¼-inch Cartridge Tape Drive) ▶ 7208-345 60 GB External 8 mm Tape Drive ▶ 7210-020 External CD-ROM ▶ 7210-025 External DVD-RAM ▶ 7329-308 SLR100 ¼-inch Tape Autoloader <p>The #5712 can be directly attached to a Linux or AIX 5 partition. When ordered as #0645 - Direct Attach #5712 PCI-X Tape/DASD Controller, an IOP is not required. When directly attached to a Linux/AIX partition, the #5712 cannot be accessed by OS/400 partitions.</p> <p>See 7.6, "Device cabling rules for #5702, #5705, #5712, #5715, #2718, and #2768 PCI Magnetic Media Controller" on page 300, for information about connecting devices to the #5712 including daisy-chaining options.</p> <p>A #5712 running in an i5/OS or OS/400 partition cannot drive internal disk units in any expansion tower, base I/O tower, or system unit enclosure.</p> <p>Minimum operating system level: i5/OS V5R3 Supported on Models 520, 550, 570, 595, and 9411-100. The #5712 is a Customer Install Feature. A #5766 PCI-X Tape Controller for IOP based tape attachment on System i models, or #5736 IOP based with #0290 - External Tape Attached Placement Code are the recommended replacements. For IOP - less tape attachment use #5775 with a #0290 - External Tape Attached Placement Code.</p>
<p>#5713</p>	<p>#5713 PCI-X 1Gbps iSCSI TOE-Copper The #5713 PCI-X 1Gbps iSCSI TOE-Copper adapter encapsulates SCSI Commands and data into TCP and transports the commands over the Ethernet via IP packets. The #5713 adapter operates as an iSCSI TCP/IP Offload Engine (TOE). The offload of the host eliminates protocol processing and reduces CPU interrupts.</p> <p>The #5713 iSCSI adapter uses an RJ45 1 Gbps Ethernet connector. The #5713 adapter can be used to initiate requests to external storage devices from AIX 5L and Linux partitions. An available PCI-X slot is required.</p> <p>Minimum operating system level: AIX 5L for POWER V5.2 for IBM eServer, SUSE Linux Enterprise Server 9 for POWER Supported on Models 520+, 550+, 570+, 595 1.9 GHz, 520, 550, 570, 595, and 9411-100. The #5713 is a Customer Install Feature.</p>
<p>#5714</p>	<p>#5714 PCI-X 1Gbps iSCSI The #5714 PCI-X 1Gbps iSCSI adapter encapsulates SCSI commands and data into TCP and transports the commands over Ethernet via IP packets. The #5714 adapter operates as an iSCSI TCP/IP Offload Engine (TOE). The offload of the host eliminates protocol processing and reduces CPU interrupts.</p> <p>The #5714 iSCSI adapter uses a small form factor LC type fiber optic connector. The #5714 adapter can be used to initiate requests to external storage devices from AIX 5L and Linux partitions. A PCI-X slot is required.</p> <p>Minimum operating system level: AIX 5L for POWER V5.2 for IBM eServer, SUSE Linux Enterprise Server 9 for POWER Supported on Models 520+, 550+, 570+, 595 1.9 GHz, 520, 550, 570, 595, and 9411-100. The #5714 is a Customer Install Feature.</p>

<p>#5715</p>	<p>#5715 PCI-X Tape/DASD Controller The #5715 PCI-X Tape/DASD Controller provides SCSI Ultra4 PCI attachment capability for external tape devices, external removable media devices, and internal DASD devices. There are two SCSI buses on each #5715. Each SCSI bus has both an internal port and an external port for a total of four ports on the card. Each SCSI bus can have only one attachment, either internal or external. Attaching internal and external devices to the same SCSI bus causes the internal device to become disabled.</p> <p>The internal SCSI port supports up to six disk units, but does not support RAID. If two external SCSI ports are required, a #5712 PCI-X Tape/DASD Controller should be ordered. When used in a Model 520, The #5715 controls disks in the #6584 4 Disk Slot Exp - PCI-X Controller.</p> <p>The external port can support the following devices:</p> <ul style="list-style-type: none"> ▶ 3580-L23 IBM TotalStorage Ultrium 2 Tape Drive ▶ 3581-L28 IBM Ultrium 2 Tape Drive ▶ 3582-L23 IBM Ultrium Tape Library LVD Ultrium2 drive feature ▶ 3583-Lxx IBM Ultrium Scalable Tape Library, LVD Ultrium 2 drive feature ▶ 3584 Ultra Scalable Tape Library, LVD Ultrium 2 drive feature ▶ 3584-L32 or D32 Ultra Scalable Tape Library, LVD Ultrium 2 ▶ 7206-VX2 80 GB VXA-2 External Tape Drive ▶ 7207-122 QIC-SLR Tape Bridge Box (4 GB External ¼-inch Cartridge Tape Drive) ▶ 7208-345 60 GB External 8 mm Tape Drive ▶ 7210-020 External CD-ROM ▶ 7210-025 External DVD-RAM ▶ 7329-308 SLR100 ¼-inch Tape Autoloader <p>See 7.6, "Device cabling rules for #5702, #5705, #5712, #5715, #2718, and #2768 PCI Magnetic Media Controller" on page 300, for information about connecting devices to the #5715 including daisy-chaining options.</p> <p>Minimum operating system level: i5/OS V5R3 Supported on Models 520, 550, 570, and 595. The #5715 is a Customer Install Feature. A #5736 for IOP-based disk attachment or #5775 for IOP-less disk attachment are the recommended replacements.</p>
<p>#5726</p>	<p>#5726 - RAID Enabler Card The #5726 provides a SCSI RAID controller which is installed into its own specific internal slot of a system unit and does not require a PCI slot. It functionally replaces the base integrated disk controller, adding RAID-5 capability and 40 MB disk controller write cache.</p> <p>The Model 570 originally used feature #5709 to describe this card. There is a slightly different enclosure kit for the card and #5726 is now used to identify the card and enclosure kit. A minimum of three disk units are required for a RAID disk array.</p> <p>Minimum operating system level: i5/OS V5R3 Supported on Model 570.</p>
<p>#5727</p>	<p>#5727 Integrated Cache 40MB The #5727 provides a SCSI RAID controller which is installed into its own specific internal slot of a system unit and does not require a PCI slot. It functionally replaces the base integrated disk controller, adding RAID-5 capability and 40 MB disk controller write cache and is capable of running in an IOP-less mode. A minimum of three disk units are required for a RAID disk array. The #9510 is a no-charge feature for Express Configurations with RAID.</p> <p>Minimum operating system level: i5/OS V5R3 and LIC V5R3M0 when running in dedicated mode (IOP required) Minimum operating system level: i5/OS V5R3 and LIC V5R3M5 when running in dual-mode (IOP-less) Supported on Models 520+ and 550+.</p>
<p>#5728</p>	<p>#5728 Integrated Cache 40MB The #5728 provides a SCSI RAID controller which is installed into its own specific internal slot of a system unit and does not require a PCI slot. It functionally replaces the base integrated disk controller, adding RAID-5 capability and 40 MB disk controller write cache and is capable of running in IOP-less mode. A minimum of three disk units are required for a RAID disk array. The # 5728 is a required feature on the Model 570+ if more than three disk are used in the processor enclosure.</p> <p>Minimum operating system level: i5/OS V5R3 and LIC V5R3M0, when running in dedicated mode (IOP required) i5/OS V5R4, when running in dual mode (IOP-less) Supported on Model 570+.</p>

#5736	<p>#5736 PCI-X Disk/Tape Controller with IOP</p> <p>The #5736 PCI-X Disk/Tape Controller with IOP provides a PCI-X Disk/Tape SCSI Controller with zero write cache and without RAID support. Disk mirroring support is supported through i5/OS. A maximum of six disk drives are supported on the #5736. Removable media devices (tape, optical libraries, CD-ROM, DVD-ROM, or DVD-RAM) are also supported on the #5736.</p> <p>The #5736 has two U320 buses each with a bus data rate of up to 320 MBs. Each SCSI bus can be either internal (using an internal port) or external (using an external port), but not both. There are four physical ports on the #5736, two internal and two external.</p> <p>Internal devices connect to the internal ports (1 or 2). External devices connect to the external ports (1 or 2) and use an Low Voltage Differential (LVD) interface and VHDCI connectors. An #1850 VHDCI to P Converter Cable is available to connect to external devices with type P connectors.</p> <p>The external ports can support the following devices:</p> <ul style="list-style-type: none"> ▶ 3580-L23 IBM TotalStorage Ultrium 2 Tape Drive ▶ 3581-L28 IBM Ultrium 2 Tape Drive ▶ 3582-L23 IBM Ultrium Tape Library LVD Ultrium2 drive feature ▶ 3583-Lxx IBM Ultrium Scalable Tape Library, LVD Ultrium 2 drive feature ▶ 3584 Ultra Scalable Tape Library, LVD Ultrium 2 drive feature ▶ 3584-L32 or D32 Ultra Scalable Tape Library, LVD Ultrium 2 ▶ 7206-VX2 80 GB VXA-2 External Tape Drive ▶ 7207-122 QIC-SLR Tape Bridge Box (4 GB External ¼-inch Cartridge Tape Drive) ▶ 7208-345 60 GB External 8 mm Tape Drive ▶ 7210-020 External CD-ROM ▶ 7210-025 External DVD-RAM ▶ 7329-308 SLR100 ¼-inch Tape Autoloader <p>An #0290 - External Tape Attached via #5736 Placement Code indicates that one external port of a #5736 is used to control an external tape device.</p> <p>The #0647, #5736, #5766 and #5775 are physically the same adapter card. The #5736 should be the choice over #5702 and #5712 PCI-X Tape/DASD Controller or #5705 and #5715 controllers for systems running i5/OS V5R3.</p> <p>Minimum operating system level: i5/OS V5R3 Supported on Models 270, 520+, 550+, 570+, 595 1.9 GHz, 520, 550, 570, 595, 800, 810, 825, 870, 890, 820, 830, and 840.</p>
#5737	<p>#5737 PCI-X Disk Controller 90MB with IOP</p> <p>The #5737 PCI-X Disk Controller 90MB with IOP provides a PCI-X SCSI disk controller that has a 90 MB write cache and can provide RAID-5 or RAID-6 protection of disk units.</p> <p>The #5737 has two U320 SCSI buses each with a bus data rate of up to 320 MBs. A maximum of 12 internal disk drives and up to two internal removable media devices (tape, CD-ROM, DVD-ROM, or DVD-RAM) are supported on the #5737.</p> <p>A minimum of three disk drives are required for RAID-5, providing protection against a single drive failure in an array. A minimum of four disk drives are required for RAID-6, providing protection against up to two drives failing in an array.</p> <p>The #0648, #5737, and #5776 are physically the same adapter card. The #2780/#5580 and #2757/#5581 disk controllers with an effective 757 MB write cache provide greater disk performance and can have an auxiliary write cache IOA to protect the write cache contents.</p> <p>Minimum operating system level: i5/OS V5R3 Supported on Models 270, 520+, 550+, 570+, 595 1.9 GHz, 520, 550, 570, 595, 800, 810, 825, 870, 890, 820, 830, and 840.</p>

<p>#5760</p>	<p>#5760 PCI-X Fibre Channel Disk Controller</p> <p>The #5760 PCI-X Fibre Channel Disk Controller provides a 4 Gbps Single Port Fibre Channel PCI-X 2.0 Adapter which attaches external DASD devices. The #5760 is a 64-bit address/data, short form factor PCI-X adapter with an LC type external fiber connector that provides single initiator capability over an optical fiber link or loop. With the use of appropriate optical fiber cabling, this adapter provides the capability for a network of high-speed local and remote located storage.</p> <p>The #5760 auto-negotiates for the highest data rate between adapter and an attaching device at 1 Gbps, 2 Gbps or 4 Gbps of which the device or switch is capable. Distances of up to 500m running at 1 Gbps data rate and up to 300m running at 2 Gbps data rate and 4 Gbps data rate up to 150m are supported between the adapter and an attaching device or switch. When used with IBM supported Fibre Channel storage switches supporting long-wave optics, distances of up to 10km are capable running at either 1 Gbps or 2 Gbps or 4 Gbps data rates.</p> <p>The #5760 can be used to attach devices either directly, or by means of Fibre Channel Switches. If attaching a device or switch with an SC type fiber connector, use of a #0371 LC-SC Adapter Kit (50um) or a #0372 LC-SC Adapter Kit (62.5um) is required.</p> <p>The #5760 requires a dedicated PCI IOP. Refer to the following IBM storage subsystem Web page for additional supported server attachment information for IBM devices. http://www.ibm.com/servers/storage/product/products_iseries.html Consult with your IBM representative or Business Partner for additional information relative to any third party attachment.</p> <p>Minimum operating system level: i5/OS V5R3 Supported on Models 520+, 550+, 570+, 595 1.9 GHz, 520, 550, 570, 595, 800, 810, 825, 870, 890.</p>
<p>#5761</p>	<p>#5761 PCI-X Fibre Channel Tape Controller</p> <p>The #5761 PCI-X Fibre Channel Tape Controller provides a 4 Gbps Single Port Fibre Channel PCI-X 2.0 adapter which attaches external tape devices. The #5761 is a 64-bit address/data, short form factor PCI-X adapter with an LC type external fiber connector that provides single initiator capability over an optical fiber link or loop. With the use of appropriate optical fiber cabling, the #5761 adapter provides the capability for a network of high-speed local and remote located storage.</p> <p>The #5761 auto-negotiates for the highest data rate between adapter and an attaching device at 1 Gbps, 2 Gbps or 4 Gbps of which the device or switch is capable. Distances of up to 500m running at 1 Gbps data rate and up to 300m running at 2 Gbps data rate and 4 Gbps data rate up to 150m are supported between the adapter and an attaching device or switch. When used with IBM supported Fibre Channel storage switches supporting long-wave optics, distances of up to 10km are capable running at either 1 Gbps or 2 Gbps or 4 Gbps data rates.</p> <p>The #5761 can be used to attach devices either directly, or by means of Fibre Channel Switches. If attaching a device or switch with an SC type fiber connector, use of a #0371 LC-SC Adapter Kit (50um) or a #0372 LC-SC Adapter Kit (62.5um) is required.</p> <p>The #5761 requires a dedicated PCI IOP. Two #5761 adapters can be under the same IOP. The #5758 and #5761 are physically the same adapter. A #5761 indicates an IOP is used.</p> <p>Refer to the following IBM storage subsystem Web page for additional supported server attachment information for IBM devices. http://www.ibm.com/servers/storage/product/products_iseries.html Consult with your IBM representative or Business Partner for additional information relative to any third party attachment.</p> <p>Minimum operating system level: i5/OS V5R3 Supported on Models 520+, 550+, 570+, 595 1.9 GHz, 520, 550, 570, 595, 800, 810, 825, 870, and 890.</p>
<p>#5766</p>	<p>#5766 PCI-X Tape Controller</p> <p>The #5766 PCI-X Tape Controller provides a PCI-X tape controller with two U320 SCSI buses for attachment of external removable media devices, either tape or optical. The two external ports have an Low Voltage Differential (LVD) interface and VHDCI connectors and are driven at the U320 SCSI bus data rate of 320 MBs. A #1850 VHDCI to P Converter Cable is available to connect to external devices with type P connectors.</p> <p>The #0647, #5736, #5766 and #5775 are physically the same adapter card. A #5766 indicates an IOP is being used.</p> <p>Minimum operating system level: i5/OS V5R3 Supported on Models 270, 800, 810, 825, 870, 890, 820, 830, and 840.</p>

#5775	<p>#5775 PCI-X Disk/Tape Controller without IOP</p> <p>The #5775 PCI-X Disk/Tape Controller without IOP provides a PCI-X Disk/Tape SCSI Controller with zero write cache and without RAID support. Disk mirroring is supported through i5/OS. A maximum of six disk drives are supported on the #5775. Removable media devices (tape, optical libraries, DVD-ROM, or DVD-RAM) are also supported on the #5775.</p> <p>The #5775 has two U320 buses each with a bus data rate of up to 320 MBs. Each SCSI bus can be either internal (using an internal port) or external (using an external port), but not both. There are four physical ports on the #5775, two internal and two external.</p> <p>Internal devices connect to the internal ports (1 or 2). External devices connect to the external ports (1 or 2) and use an Low Voltage Differential (LVD) interface and VHDCI connectors. A #1850 VHDCI to P Converter Cable is available to connect to external devices with type P connectors.</p> <p>The #0647, #5736, #5766 and #5775 are physically the same adapter card. The #5775 should be the choice over #0624/#0645 (#5702 and #5712 IOP-less equivalent) or #5705/#5715 controllers for systems running i5/OS V5R3 or later when attaching devices that do not require an IOP/IOA combination. The #5775 does not support 358x or 359x tape devices. Use a #5702, #5705, #5712, #5715, #5736 or #5766 (IOP-based) to attach a 358x or 359x.</p> <p>Minimum operating system level: i5/OS V5R4; or i5/OS V5R3 with LIC V5R3M5 on Model 520+. Supported on Models 520+, 550+, 570+, 595 1.9 GHz, 520, 550, 570, and 595.</p>
#5776	<p>#5776 PCI-X Disk Controller 90MB without IOP</p> <p>The #5776 PCI-X Disk Controller 90MB without IOP provides a PCI-X SCSI disk controller that has a 90 MB write cache. In addition to providing RAID-5 or RAID-6 protection for disks, the #5776 is designed to work as a high performance controller for disks protected by system mirroring or disks with no protection.</p> <p>The #5776 has two U320 SCSI buses each with a bus data rate of up to 320 MBs. A maximum of 12 internal disk drives and up to two internal removable media devices (tape, DVD-ROM, or DVD-RAM) are supported on the #5776.</p> <p>A minimum of three disk drives are required for RAID-5, providing protection against a single drive failure in an array. A minimum of four disk drives are required for RAID-6, providing protection against up to two drives failing in an array.</p> <p>The #0648, #5737, and #5776 are physically the same adapter card.</p> <p>The #2780/#5580 and #2757/#5581 disk controllers with an effective 757 MB write cache provide greater disk performance and can have an auxiliary write cache IOA to protect the write cache contents.</p> <p>Minimum operating system level: i5/OS V5R4; or i5/OS V5R3 with LIC V5R3M5 on Model 520+. Supported on Models 520+, 550+, 570+, 595 1.9 GHz, 520, 550, 570, 595, or attached I/O tower/drawers #0595, #5095, #5094, #5294, #8294, #9194, #5074, and #5079.</p>

Archived

Customer Install Features

Many System i models are designated as Customer Setup (CSU). Several of the features for the current System i product line are Customer Install Features (CIF). CIF and CSU designations provide the client with flexibility in installing new System i servers and adding new features to installed systems. Clients can schedule installations to minimize the disturbance to their business operations.

Miscellaneous Equipment Specification (MES) is an IBM term for IBM-supplied changes to an installed or on-order system. On MES orders that include a mixture of IBM install and CIF features, the client can choose to have the IBM service representative install all of the features, including those designated as CIF. On MES orders where all features are CIF, the client can install all of the features.

The client is responsible for the installation of external cables, displays, printers, and modems. IBM service personnel can perform these activities for a charge. IBM installation for CSU and CIF units is available for a charge under normal service contracts.

The tables in this chapter list the commonly ordered feature codes for the IBM System i5, eServer i5, and iSeries models. They identify which features are CIF features, in which model and expansion unit the feature is supported, and the minimum release of i5/OS or OS/400 required to support the feature.

The columns in the following tables contain:

- ▶ The feature code (FC)
- ▶ The feature description as used in the IBM marketing configurator
- ▶ A Y if the feature is a CIF, or an N if it is an “installed by IBM” feature
- ▶ How the features are installed in each of the System i5, eServer, and iSeries models

The installation options are defined as follows:

- **B**: Plant or MES installation
- **M**: MES install only (available for field installation only)
- **P**: Plant install only (available on new system orders only)
- **PU**: Plant install only; for model upgrades, an MES install

- **S:** Supported in the specified System i model configuration
The feature can be migrated to the specified System i5, eServer i5, and iSeries model as part of a model upgrade, but individual orders are not available.
- **SC:** Supported for conversion
- ▶ **Minimum operating system level**
The operating system version and release that supports the feature, either natively or with program temporary fixes (PTFs)

For further information about the features represented in these tables, refer to:

- ▶ Chapter 4, “IBM System i5, eServer i5, and iSeries features and placement” on page 97 for further information about each feature
- ▶ Chapter 8, “Customer Card Identification Numbers cross reference” on page 303 for a comprehensive list of CCINs
- ▶ Chapter 9, “Feature code cross reference” on page 323 for a comprehensive list of features
- ▶ Chapter 11, “HSL, SPCN, line cord, and communication cables for IBM System i5, eServer i5, and iSeries systems” on page 377 for a comprehensive list of cables

More information, including part numbers, is also available at the Information Center Web site at:

<http://www.ibm.com/eserver/series/infocenter>

When you reach this site, select **Planning** → **Cables**.

5.1 IBM System i5 and eServer Models 520, 550, 570, 595 system unit and tower supported features

The tables in this chapter list the commonly ordered feature codes for the IBM System i5 and eServer i5 models. They identify which features are CIF features, in which model and expansion unit the feature is supported, and the minimum release of i5/OS required to support the feature.

The following table shows the features supported in Models 520, 550, 570, 595, and the associated expansion units, the CIF designation, and minimum i5/OS operating system level of each feature. Dashes (“---”) in the operating system column indicate that the adapter is not supported by i5/OS. The feature might be supported by AIX or Linux.

For current details about AIX and Linux supported features, see:

http://www.ibm.com/servers/eserver/series/aix/pdf/facts_features.pdf

http://www.ibm.com/servers/eserver/linux/power/hardware/linux_facts.pdf

Note: Only the Linux for Power versions of Linux are supported on the System i5 Models 520, 550, 570, and 595.

Refer to Chapter 4, “IBM System i5, eServer i5, and iSeries features and placement” on page 97 to understand the minimum operating system requirements by feature code, and the processors each feature is supported in.

Note: i5/OS V5R3 is the minimum operating system for each feature on an IBM System i5 or eServer i5 system. Therefore, the “Minimum operating system i5/OS” column in the following table is V5R3. Some features can also require a minimum LIC level.

Although a feature itself might be supported in an earlier release than i5/OS V5R3, this is not true of the i5 systems. As such, the following table can be considered to be a “view” of the features supported on a specific i5 model, and what the minimum i5/OS of that feature is on the i5 model.

Feature code and description	CIF	Model or tower								Minimum i5/OS level
		520 (9405/9406)	550	570	595	#5095/#0595	#5074/#5094/#5294	#5088/#0588	#5790	
#0040 Mirrored System Disk Level	Y	B	B	B	B	-	-	-	-	V5R3
#0041 Device Parity Protection-All	Y	B	B	B	B	-	-	-	-	V5R3
#0042 Mirrored System IOP Level	Y	B	B	B	B	-	-	-	-	V5R3
#0043 Mirrored System Bus Level	Y	B	B	B	B	-	-	-	-	V5R3
#0047 Device Parity RAID-6 All	Y	M/B	B	B	B					V5R3
#0092 External xSeries Attach	Y	B	B	B	B	-	-	-	-	V5R3
#0123 #5074 Lower Unit in Rack	Y	S	-	S		-	-	-	-	V5R3
#0126 CEC Reduction Specify	N	-	-	-	B	-	-	-	-	V5R2
#0140 Logical Partitioning Specify	Y	B	B	B	B	-	-	-	-	V5R3
#0141 HSL OptiConnect Specify	Y				B	-	-	-	-	V5R3
#0142 Linux Partition Specify	Y	B	B	B	B	-	-	-	-	V5R3
#0145 AIX Partition Specify	Y	B	B	B	B	-	-	-	-	V5R3
#0290 External Tape Attached via #5736	Y	M/B	B	B	B					V5R3
#0299 MES Conversion	N	B	B	B	B	B	B	B	B	V5R3
#0325 IPCS Extension Cables for NT	Y	B	B	B	B	B	B	B	B	V5R3
#0367 Operations Console PCI Cable	Y	B	B	B	B	B	B	B	B	V5R3
#0369 100m Optical SPCN Cable	Y	-	-	B		B	B	B	B	V5R3
#0371 LC-SC Adapter Kit (50 um)	Y	B	B	B	B	B	B	B	B	V5R3
#0372 LC-SC Adapter Kit (62.5 um)	Y	B	B	B	B	B	B	B	B	V5R3
#0446 512 MB DDR Server Memory	Y	B	B	B	B	B	B	B		V5R3
#0447 1 GB DDR Server Memory	Y	B	B	B	B	B	B	B		V5R3
#0454 LPAR Partition Init	N			P	P	-	-	-	-	V5R3
#0455 LPAR OS Preload	N			P	P	-	-	-	-	V5R3

Feature code and description	CIF	Model or tower								Minimum i5/OS level
		520 (9405/9406)	550	570	595	#5095/#0595	#5074/#5094/#5294	#5088/#0588	#5790	
#0496 Force i5/OS Preload exclusive with #0006	N	P	P	P	P	-	-	-	-	V5R3
#0532 i5/OS V5R4, V5R4M0 LIC	Y	B	B	B	B	-	-	-	-	V5R4
#0551 iSeries Rack	Y	B	B	B	B	-	-	-	-	V5R3
#0553 2M iSeries Rack		B	B	B	B	-	-	-	-	V5R3
#0588 PCI-X Expansion Unit in Rack	Y	B	B	B	B	-	-	-	-	V5R3
#0595 PCI-X Expansion Unit in Rack	Y	B	B	B	B	-	-	-	-	V5R3
#0599 Rack Filler Kit for #0551,#0553	Y	-	-	-	-	-	-	-	-	N/A
#0601 - Direct Attach #2743 PCI 1 Gbps Ethernet IOA	Y	SC	SC	SC	SC	S	S	S	S	---
#0602 - Direct Attach #2760 PCI 1 Gbps Ethernet UTP IOA	Y	SC	SC	SC	SC	S	S	S	S	---
#0603 - Direct Attach #2744 PCI 100 Mbps Token-Ring IOA	Y	B	B	B	B	B	B	B	B	---
#0607 - Direct Attach #4838 PCI 100/10 Mbps Ethernet IOA	Y	SC	SC	SC	SC	S	S	S	S	---
#0608 - Direct Attach #4745 PCI WAN IOA	Y	SC	SC	SC	SC	S	S	S	S	---
#0609 - Direct Attach #2772 PCI Dual WAN/Modem IOA	Y	B	B	B	B	B	B	B	B	---
#0610 - Direct Attach #2773 PCI Dual WAN/ModemIOA	Y	B	B	B	B	B	B	B	B	---
#0611 - Direct Attach #2765 PCI Fibre Channel Tape Controller	Y	B	B	B	B	B	B	B	B	---
#0612 - Direct Attach #2766 PCI Fibre Channel Disk Controller	Y	M	M	M	M	B	B	B	B	---
#0613 - Direct Attach #2742 PCI 2-Line WAN IOA	Y	B	B	B	B	B	B	B	B	---
#0614 - Direct Attach #2793 PCI 2-Line WAN w/Modem	Y	B	B	B	B	B	B	B	B	---
#0615 - Direct Attach #2794 PCI 2-Line WAN w/Modem	Y	B	B	B	B	B	B	B	B	---
#0616 - Direct Attach #2805 PCI Quad Modem IOA	Y	B	B	B	B	B	B	B	B	---
#0617 - Direct Attach #2806 PCI Quad Modem (CIM)	Y	B	B	B	B	B	B	B	B	---
#0620 - Direct Attach #5700 PCI 1 Gbps Ethernet IOA	Y	B	B	B	B	B	B	B	B	---
#0621 - Direct Attach #5701 PCI 1 Gbps Ethernet UTP IOA	Y	B	B	B	B	B	B	B	B	---

Feature code and description	CIF	Model or tower								Minimum i5/OS level
		520 (9405/9406)	550	570	595	#5095/#0595	#5074/#5094/#5294	#5088/#0588	#5790	
#0623 - Direct Attach #2849 PCI 100/10 Mbps Ethernet IOA	Y	B	B	B	B	B	B	B	B	---
#0624 - Direct Attach #5702 PCI-X Ultra Tape Controller	Y	M	M	M	M	B	B	B	B	---
#0625 - Direct Attach #5704 PCI-X Fibre Channel Tape Controller	Y	B	B	B	B	B	B	B	B	---
#0626 - Direct Attach #2787 PCI-X Fibre Channel Disk Controller	Y	B	B	B	B	B	B	B	B	---
#0627 - Direct Attach #2780 PCI-X Ultra4 RAID Disk Controller	Y	B	B	B	B	B	B	-	-	---
#0628 - Direct Attach #5703 PCI-X RAID Disk Unit Controller	Y	B	B	B	B	B-	B	-	-	---
#0632 PCI USB 2.0 Adapter	Y	B	B	B	B	B	B	B	B	---
#0633 Graphics Adapter	Y	B	B	B	B	B	B	B	B	---
#0634 128-Port Async Adapter	Y	B	B	B	B	B	B	B	B	---
#0635 SDLC/X.25 - 2-Port Adapter	Y	B	B	B	B	B	B	B	B	---
#0642 PCI Ultra-3 RAID Adapter	Y	B	B	B	B	B	B	-	B	---
#0643 - Direct Attach #5706 PCI-X Gbps Ethernet-TX IOA	Y	B	B	B	B	B	B	B	B	---
#0644 - Direct Attach #5707 PCI-X 1 Gbps Ethernet-SX IOA	Y	B	B	B	B	B	B	B	B	---
#0645 - Direct Attach #5712 PCI-X Tape/DASD Controller	Y	B	B	B	B	B	B	B	B	---
#0647 PCI-X Disk/Tape Controller without IOP	Y	M/B	B	B	B	B	S/B	B	B	---
#0648 PCI-X Disk Controller 90MB without IOP	Y	M/B	B	B	B	B	S/B	B	B	---
#0694 - #5094 Equivalent	Y	B	B	B	B	-	-/B	-	-	V5R3
#0836 - #4328 Load Source Specify	N	B	B	B	B	-	-	-	-	V5R3
#0837 SAN Load Source Specify	N	B*	B	B	B	-	-	-	-	V5R3
#0906 1-way Server Feature	Y	-/B*	-	-	-	-	-	-	-	V5R3
#0910 1/4-way Server Feature	Y	-	B	-	-	-	-	-	-	V5R3
#0915 1/4-way Server Feature	Y	-	B	-	-	-	-	-	-	V5R3
#0934 2/4-way Server Feature	Y	-	-	B	-	-	-	-	-	V5R3
#0935 4/8-way Server Feature	Y	-	-	B	-	-	-	-	-	V5R3
#0936 8/16-way Server Feature	y	-	-	B	-	-	-	-	-	V5R3
#0937 2/16-way Server Feature	Y	-	-	B	-	-	-	-	-	V5R3

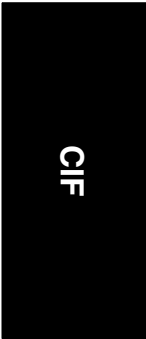

CIF

Feature code and description	CIF	Model or tower								Minimum i5/OS level
		520 (9405/9406)	550	570	595	#5095/#0595	#5074/#5094/#5294	#5088/#0588	#5790	
#0940 8/16-way Server Feature	Y	-	-	-	B	-	-	-	-	V5R3
#0941 16/32-way Server Feature	Y	-	-	-	B	-	-	-	-	V5R3
#0943 32/64-way Server Feature	Y	-	-	-	B	-	-	-	-	V5R3
#0944 4/32-way Server Feature	Y	-	-	-	B	-	-	-	-	V5R3
#0946 8/16-way Server Feature	N	-	-	-	B	-	-	-	-	V5R3
#0970 1-way Server Feature	Y	B/-*	-	-	-	-	-	-	-	V5R3
#0975 1-way Server Feature	Y	-/B*	-	-	-	-	-	-	-	V5R3
#1307 - 1.75m HSL-2/RIO-G Cable	Y	B	B	B	B	B	B	B	B	V5R3
#1308 - 2.5m HSL-2/RIO-G Cable	Y	B	B	B	B	B	B	B	B	V5R3
#1460 3m Copper HSL Cable	Y	B	B	B	B	-	-	-	-	V5R3
#1461 6m Copper HSL Cable	Y	-	-	-	B	-	-	-	-	V5R3
#1462 15m Copper HSL Cable	Y	-	-	-	B	-	-	-	-	V5R3
#1463 2m SPCN Cable	Y	S	S	S	S	B	B	B	-	V5R3
#1464 6m SPCN Cable	Y	S	S	S	S	B	B	B	-	V5R3
#1465 15m SPCN Cable	Y	S	S	S	S	B	B	B	-	V5R3
#1466 30m SPCN Cable	Y	S	S	S	S	B	B	B	-	V5R3
#1468 250m Optical SPCN Cable	Y	-	B	B	B	B	B	B	B	V5R3
#1470 6m Optical HSL Cable	Y	-	B	B	B	B	B	B	-	V5R3
#1471 30m Optical HSL Cable	Y	-	-	S	S	B	B	B	-	V5R3
#1472 100m Optical HSL Cable	Y	-	B	B	B	B	B	B	-	V5R3
#1473 250m Optical HSL Cable	Y	-	B	B	B	B	B	B	-	V5R3
#1474 6m HSL to HSL-2 Cable	Y	B	B	B	B	B	B	B	B	V5R3
#1475 10m HSL to HSL-2 Cable	Y	B	B	B	B	B	B	B	B	V5R3
#1476 - 4.3m 200V/12A Power Cord U.K.	Y	B	B	B	B	-	B	-	-	V5R3
#1481 - 1.2m HSL-2/RIO-G Cable	Y	B	B	B	B	-	-	-	B	V5R3
#1482 3.5m HSL-2 Cable	Y	B	B	B	B	-	B	B	B	V5R3
#1483 10m HSL-2 Cable	Y	B	B	B	B	-	B	B	B	V5R3
#1485 15m HSL-2 Cable	Y	B	B	B	B	-	B	B	-	V5R3
#1700 IPCS Keyboard/Mouse for NT	Y	B	B	B	B	B	B	B	B	V5R3
#1800 HSL-2 Ports - 2 Copper	Y	-	-	B	-	-	-	-	-	V5R3
#1801 Optical Bus Expansion Card - 2 port	Y	-	-	B	-	-	-	-	-	V5R3

Feature code and description	CIF	Model or tower								Minimum i5/OS level
		520 (9405/9406)	550	570	595	#5095/#0595	#5074/#5094/#5294	#5088/#0588	#5790	
#1893 36.4 GB 10K RPM Disk Unit	Y	B	B	B	S	-	-	-	-	---
#1894 73.4 GB 10K RPM Disk Unit	Y	B	B	B	S	-	-	-	-	---
#1895 146.8 GB 10K RPM Disk Unit	Y	B	B	B	S	B	-/B	-	-	---
#1896 36.4 GB 15K RPM Disk Unit	Y	B	B	B	B	B	-/B	-	-	---
#1897 73.4 GB 15K RPM Disk Unit	Y	B	B	B	B	B	-/B	-	-	---
#1898 146.8GB Disk Unit	Y	M/B	B	B	B	B	-/B	-	-	---
#2591 External 1.44 MB Diskette Drive	Y	B	B	B	B	-	-/B	-	B	---
#2640 IDE DVD-ROM (slim-line)	Y	B	B	B	-	-	-	-	-	V5R3
#2737 PCI HIPPI SW	Y	-	-	S	S	B	S/B	S	B	---
#2739 Optical Bus Adapter	N	-	B	B	B	-	B/-	-	-	V5R3
#2742 Two-Line WAN IOA	Y	B	B	B	B	B	B	B	B	V5R3
#2743 1 Gbps PCI Ethernet IOA	Y	SC	SC	SC	SC	S	S	S	S	V5R3
#2744 PCI 100 Mbps Token Ring IOA	Y	B	B	B	B	B	B	B	B	V5R3
#2749 PCI Ultra Magnetic Media Controller	Y	S	S	S	B	B	B	B	B	V5R3
#2757 PCI-X Ultra RAID Disk Controller	Y	B	B	B	B	B	S/B	-	-	V5R3
#2760 PCI 1 Gbps Ethernet UTP Adapter	Y	SC	SC	SC	SC	B	S/B	B	B	V5R3
#2763 PCI RAID Disk Unit Controller	Y	-/S	S	S	S	B	-	-	-	V5R3
#2765 PCI Fibre Channel Tape Controller	Y	-/S	S	S	S	S	S	S	S	V5R3
#2766 PCI Fibre Channel Disk Controller	Y	-/ SC	SC	SC	SC	S	S	S	S	V5R3
#2768 PCI Magnetic Media Controller	Y	-/ SC	-	SC	-	-	-	-	-	V5R2
#2772 PCI Dual WAN/Modem IOA	Y	B	B	B	B	B	B	B	B	V5R3
#2773 PCI Dual WAN/Modem IOA	Y	B	B	B	B	B	B	B	B	V5R3
#2780 PCI-X Ultra4 RAID Disk Controller	Y	B	B	B	B	B	B	-	-	V5R3
#2782 PCI-X RAID Disk Unit Controller	Y	S	S	S	S	B	B	-	-	V5R3
#2787 PCI-X Fibre Channel Disk Controller	Y	B	B	B	B	B	B	B	B	V5R3
#2793 Two-Line WAN IOA with Modem	Y	B	B	B	B	B	B	B	B	V5R3
#2794 Two-Line WAN IOA with Modem	Y	B	B	B	B	B	B	B	B	V5R3
#2805 PCI Quad Modem IOA	Y	B	B	B	B	B	B	B	B	V5R3
#2806 PCI Quad Modem (CIM)	Y	B	B	B	B	B	B	B	B	V5R3
#2843 PCI IOP	Y	SC	SC	SC	SC	S	S	S	S	V5R3

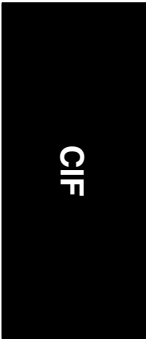

Feature code and description	CIF	Model or tower								Minimum i5/OS level
		520 (9405/9406)	550	570	595	#5095/#0595	#5074/#5094/#5294	#5088/#0588	#5790	
#2844 PCI IOP	Y	B	B	B	B	B	B	B	B	V5R3
#2847 PCI IOP for SAN Load Source*	Y	B	B	B	B	B	B	B	B	V5R3*
#2849 10/100 Mbps Ethernet Adapter	Y	B	B	B	B	B	B	B	B	V5R3
#2886 Optical Bus Adapter	Y	-	M	M	M	M	M	M	-	V5R3
#2887 HSL-2 Bus Adapter	Y	-	M	M	M	M	M	M	-	V5R3
#2888 RIO-G Ports - 2 Copper	Y	M/B*	-	-	-	-	-	-	-	V5R3
#2890 PCI Integrated Netfinity Server	Y	-				B	S/B	B	-	V5R3
#2891 PCI Integrated xSeries Server	Y	-				B	S/B	B	-	V5R3
#2892 PCI Integrated xSeries Server	Y	-	-	-		B	S/B	B	-	V5R3
#2895 128 MB Server Memory	Y	SC	SC	SC	SC	S	S	S	-	V5R3
#2896 256 MB Server Memory	Y	M	M	M	M	M	M	M	-	V5R3
#2897 1 GB Server Memory	Y	M	M	M	M	M	M	M	-	V5R3
#2899 PCI Integrated xSeries Server	Y	-	-	-	-	B	S/B	B	-	V5R3
#2943 8-Port Async Adapter	Y	B	B	B	B	B	-/B	-	B	---
#2947 PCI Multiprotocol Adapter	Y	B	B	B	B	B	-/B	-	B	---
#3043 - 512 MB Main Storage	N	-	-	S	-	-	-	-	-	V5R3
#3044 1024 MB Main Storage	Y	-	-	S	-	-	-	-	-	V5R3
#3046 2048 MB Main Storage	Y	-	-	S	-	-	-	-	-	V5R3
#3093 512 MB Main Storage	Y	S	S	-	-	-	-	-	-	V5R3
#3094 1024 MB Main Storage	Y	S	S	-	-	-	-	-	-	V5R3
#3096 2048 MB Main Storage	Y	S	-	-	-	-	-	-	-	V5R3
#3578 300 GB 10K rpm Drive	Y	B	B	B	SC	B	B	-	-	V5R3
#3757 Service Shelf Toolkit		-	-	-	B	-	-	-	-	V5R3
#4263 Direct Attach Tape Cable	Y	B	B	-	-	-	-	-	-	---
#4317 8.58 GB 10k RPM Disk Unit	Y	SC	SC	SC	SC	B	S/B	-	-	V5R3
#4318 17.54 GB 10k RPM Disk Unit	Y	SC	SC	SC	SC	B	S/B	-	-	V5R3
#4319 35.16 GB 10k RPM Disk Unit	Y	B	B	B	B	B	S/B	-	-	V5R3
#4326 35.16 GB 15k RPM Disk Unit	Y	B	B	B	B	B	-/B	-	-	V5R3
#4327 70.56 GB 15k RPM Disk Unit	Y	B	B	B	B	B	B	-	-	V5R3
#4328 141.12 GB 15K rpm Disk Unit	Y	B	B	B	B	B	-/B	-	-	V5R3
#4400 1GB DDR2 Main Storage	Y	M/B*	B	-	-	-	-	-	-	V5R3

Feature code and description	CIF	Model or tower								Minimum i5/OS level
		520 (9405/9406)	550	570	595	#5095/#0595	#5074/#5094/#5294	#5088/#0588	#5790	
#4425 CD-ROM	Y	-	-	-	-	-	S/B	-	-	V5R3
#4430 DVD-RAM	Y	-	-	-	-	-	S/B	-	-	V5R3
#4443 - 512 MB Main Storage	Y	B	B	-	-	-	-	-	-	V5R3
#4444 - 1 GB Main Storage	Y	B	B	-	-	-	-	-	-	V5R3
#4445 - 4 GB Main Storage	Y	B	B	-	-	-	-	-	-	V5R3
#4447 - 2 GB Main Storage	Y	B	B	-	-	-	-	-	-	V5R3
#4449 - 8 GB Main Storage	Y	B	B	-	-	-	-	-	-	V5R3
#4450 - 16 GB Main Storage	Y	B	B	-	-	-	-	-	-	V5R3
#4452 - 2 GB Main Storage	N	-	-	B	-	-	-	-	-	V5R3
#4454 - 8 GB Main Storage	Y	-	-	B	-	-	-	-	-	V5R3
#4474 2GB DDR2 Main Storage	Y	M/B*	B	-	-	-	-	-	-	V5R3
#4475 4GB DDR2 Main Storage		M/B*	B	-	-	-	-	-	-	V5R3
#4477 8GB DDR2 Main Storage		M/B*	B	-	-	-	-	-	-	V5R3
#4482 4GB ¼-inch Cartridge Tape Device	Y	SC	SC	SC	SC	-	S/B	-	-	V5R3
#4483 16 GB ¼-inch Cartridge Tape Device	Y	SC	SC	SC	SC	-	S/B	-	-	V5R3
#4486 25 GB ¼-inch Cartridge Tape Device	Y	SC	SC	SC	SC	-	S/B	-	-	V5R3
#4487 50 GB ¼-inch Cartridge Tape Device	Y	SC	SC	SC	SC	-	S/B	-	-	V5R3
#4490 - 4 GB Main Storage	Y	-	-	B	-	-	-	-	-	V5R3
#4491 - 16 GB Main Storage	Y	-	-	B	-	-	-	-	-	V5R3
#4495 4/8GB DDR2 Main Storage	N	-	-	B	-	-	-	-	-	V5R3
#4496 8/16GB DDR2 Main Storage	N	-	-	B	-	-	-	-	-	V5R3
#4497 16GB DDR2 Main Storage	N	-	-	B	-	-	-	-	-	V5R3
#4498 32GB DDR2 Main Storage	N	-	-	B	-	-	-	-	-	V5R3
#4625 CD-ROM	Y	-	-	-	M	-	SC	-	-	V5R3
#4630 DVD-RAM	Y	-	-	-	M	-	SC	-	-	V5R3
#4631 DVD-ROM	Y	-	-	-	B	-	B	-	-	V5R3
#4633 DVD-RAM	Y	-	-	-	B	-	B	-	-	V5R3
#4643 - 7040-61D I/O Drawer attached	Y	-	-	-	S	-	-	-	-	---
#4682 4 GB ¼-inch Cartridge Tape Device	Y	SC	SC	SC	SC	-	S/B	-	-	V5R3
#4683 - 16 GB QIC Cartridge Tape Device	Y	SC	SC	SC	SC	-	S/B	-	-	V5R3
#4684 30 GB ¼-inch Cartridge Tape Device	Y	SC	SC	SC	SC	-	S/B	-	-	V5R3

CIF

Feature code and description	CIF	Model or tower								Minimum i5/OS level
		520 (9405/9406)	550	570	595	#5095/#0595	#5074/#5094/#5294	#5088/#0588	#5790	
#4685 80 GB VXA-2 Tape Device	Y	SC	SC	SC	SC	-	S/B	-	-	V5R3
#4686 25 GB ¼-inch Cartridge Tape Device	Y	SC	SC	SC	SC	-	S/B	-	-	V5R3
#4687 50 GB ¼-inch Cartridge Tape Device	Y	B	B	B	B	-	S/B	-	-	V5R3
#4690 Rack Status Beacon Assembly	Y	B	B	B	B	-	-	-	-	---
#4710 PCI Integrated xSeries Server	Y	-	-	-	-	B	B	B	-	V5R3
#4723 PCI 10 Mbps Ethernet Adapter	Y	SC	SC	SC	SC	B	S/B	B	B	V5R3
#4745 PCI 2-line WAN IOA	Y	S	S	S	S	B	S/B	B	B	V5R3
#4746 PCI Twinaxial IOA	Y	B	B	B	B	B	S/B	B	B	V5R3
#4748 PCI RAID Disk Unit Controller	Y	S	S	S	S	B	S/B	-	-	V5R3
#4778 PCI RAID Disk Unit Controller	Y	S	S	S	S	B	S/B	-	-	V5R3
#4801 PCI Cryptographic Coprocessor	Y	B	B	B	B	B	S/B	B	B	V5R3
#4805 PCI Cryptographic Accelerator	Y	B	B	B	B	B	S/B	B	B	V5R3
#4806 PCI-X Cryptographic Coprocessor	Y	B	B	B	B	B	S/B	B	B	V5R3
#4810 PCI Integrated xSeries Server	Y	B	B	B	B	B	S/B	B	-	V5R3
#4811 PCI-X Integrated xSeries Server	Y	B	-	-	-	-	-	-	-	V5R3
#4812 PCI-X Integrated xSeries Server	Y	-	B	-	-	B	B	B	-	V5R3
#4813 PCI-X Integrated xSeries Server	Y	-	-	-	-	-	-	-	B	V5R3
#4838 PCI 100/10 Mbps Ethernet IOA	Y	S	S	S	S	B	S/B	S	S	V5R3
#4959 PCI 16/4 Mbps Token Ring Adapter	Y	B	B	B	B	B	S/B	-	B	---
#4962 PCI 100/10 Mbps Ethernet IOA	Y	B	B	B	B	B	S/B	B	B	---
#5074 PCI Expansion Tower	Y	S	S	S	S	-	-	-	-	V5R3
#5079 1.8 m I/O Tower	Y	S	S	S	S	-	-	-	-	V5R3
#5088 PCI-X Expansion Unit	N	B	B	B	B	-	B	-	-	V5R3
#5094 PCI-X Expansion Tower	Y	B	B	B	B	-	-	-	-	V5R3
#5095 PCI-X Expansion Tower	Y	B	B	B	B	-	-	-	-	V5R3
#5108 30 Disk Expansion Feature	N	-	-	-	-	-	B	-	-	V5R3
#5115 Dual Line Cords Tower	Y	-	-	-	-	-	B	-	-	V5R3
#5116 Dual Line Cords - 5294 Tower	Y	-	-	-	-	-	B	-	-	V5R3
#5138 Redundant Power and Cooling	Y	-	B	-	-	B	-	-	-	V5R3
#5158 AC Power Supply, 850W	Y	B	-	-	-	-	-	-	-	V5R3
#5159 850 Watt Power Supply	Y	M/B*	-	-	-	-	-	-	-	V5R3

Feature code and description	CIF	Model or tower								Minimum i5/OS level
		520 (9405/9406)	550	570	595	#5095/#0595	#5074/#5094/#5294	#5088/#0588	#5790	
#5160 Power Dist. Unit 1 Phase NEMA	N	-	-	-	-	-	-	-	-	V5R3
#5161 Power Distribution Unit	N	-	-	-	-	-	-	-	-	V5R3
#5162 Power Distribution Unit	N	-	-	-	-	-	-	-	-	V5R3
#5163 Power Distribution Unit	Y	-	-	-	-	-	-	-	-	V5R3
#5294 1.8m I/O Tower	Y	B	B	B	B	-	-	-	-	V5R3
#5540 System Console on Twinaxial Workstation IOA	Y	B	B	B	B	-	-	-	-	V5R3
#5544 System Console on Operations Console	Y	B	B	B	B	-	-	-	-	V5R3
#5546 System Console on 100 Mbps Token Ring	Y	B	B	B	B	-	-	-	-	V5R3
#5548 System Console on 100 Mbps Ethernet	Y	B	B	B	B	-	-	-	-	V5R3
#5550 System Console on HMC	Y	B	B	B	B	-	-	-	-	V5R3
#5553 System Console Ethernet w/o IOP	Y	M/B*	B	B	-	-	-	-	-	V5R3
#5554 Mirror 35GB Disk/Controller Package	Y	B	B	B	B					V5R2
#5555 Mirror 70 GB Disk/Controller Package	Y	B	B	B	B					V5R2
#5556 Mirroring 140 GB Disk/Controller Package	Y	B	B	B	B					V5R3
#5557 System Console Ethernet w/o IOP	Y				B					V5R4
#5560 Mirror 35 GB Drawer Package	Y	B	B	B	B					V5R2
#5561 Mirror 70 GB Drawer Package	Y	B	B	B	B					V5R2
#5562 Mirror 35 GB Tower Package	Y	B	B	B	B					V5R2
#5563 Mirror 70 GB Tower Package	Y	B	B	B	B					V5R2
#5580 - #2780 Controller with Auxiliary Write Cache	Y	B	B	B	B	B	S/B	-	-	V5R3
#5581 - #2757 Controller with Auxiliary Write Cache	Y	B	B	B	B	B	S/B	-	-	V5R3
#5700 PCI 1 Gbps Ethernet IOA	Y	B	B	B	B	B	S/B	B	B	V5R3
#5701 PCI 1 Gbps Ethernet UTP IOA	Y	B	B	B	B	B	S/B	B	B	V5R3
#5702 PCI-X Ultra Tape Controller	Y	S	S	S	S	S	S/B	B	B	V5R3
#5703 PCI-X Tape/DASD Controller	Y	B	B	B	B	B	S/B	B	B	V5R3
#5704 PCI-X Fibre Channel Tape Controller	Y	B	B	B	B	B	S/B	B	B	V5R3
#5706 PCI-X 1Gbps Ethernet-TX IOA	Y	B	B	B	B	B	S/B	B	B	V5R3
#5707 1 Gbps Ethernet Adapter (Fiber)	Y	B	B	B	B	B	S/B	B	B	V5R3
#5709 RAID Enabler Card	Y	B	B	B	-	-	-	-	-	V5R3

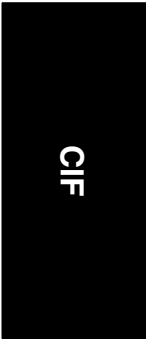

Feature code and description	CIF	Model or tower								Minimum i5/OS level
		520 (9405/9406)	550	570	595	#5095/#0595	#5074/#5094/#5294	#5088/#0588	#5790	
#5712 PCI-X Tape/DASD Controller	Y	B	B	B	B	B	S/B	B	B	V5R3
#5713 PCI-X 1Gbps iSCSI TOE-Copper	Y	M/B	B	B	B	B	-/B	-	B	---
#5714 PCI-X 1Gbps iSCSI	Y	M/B	B	B	B	B	-/B	-	B	---
#5715 PCI-X Tape/DASD Controller	Y	B	B	B	B	B	-/B	-	-	V5R3
#5718 10 Gbps Ethernet Adapter (short)	Y	B	B	B	B	B	S/B	B	B	---
#5726 RAID Enabler Card	N	-	-	B	-	-	-	-	-	V5R3
#5727 Integrated Cache 40MB	Y	M/B	B	-	-	-	-	-	-	V5R3
#5728 Integrated Cache 40MB	Y	-	-	B	-	-	-	-	-	V5R3
#5736 PCI-X Disk/Tape Controller with IOP	Y	M/B	B	B	B	B	S/B	B	B	V5R3
#5737 PCI-X Disk Controller 90MB with IOP	Y	M/B	B	B	B	B	S/B	B	B	V5R3
#5740 1Gbps BaseT Ethernet (4-port)	Y	M/B	B	B	B	B	S/B	B	B	---
#5751 DVD-RAM	Y	B	B	B	-	-	-	-	-	V5R3
#5753 30 GB ¼-inch Cartridge Tape Device	Y	B	B	-	-	-	-	-	-	V5R3
#5754 50 GB ¼-inch Cartridge Tape Device	Y	B	B	-	-	-	-	-	-	V5R3
#5755 200 GB LTO-2 Tape Unit	Y	B	B	-	-	-	-	-	-	V5R3
#5760 PCI-X Fibre Channel Disk Controller	Y	M/B	B	B	B	B	S/B	B	B	V5R3
#5761 PCI-X Fibre Channel Tape Controller	Y	M/B	B	B	B	B	S/B	B	B	V5R3
#5775 PCI-X Disk/Tape Controller without IOP	Y	M/B*	B	B	B					V5R4
#5776 PCI-X Disk Controller 90MB without IOP	Y	M/B*	B	B	B					V5R4
#5790 PCI Expansion Drawer	Y	B	B	B	-	-	-	-	-	V5R3
#6068 Optional Front Door for 1.8m Rack	Y	B	B	B	B	-	-	-	-	V5R3
#6134 60 GB 8mm Tape Device	Y	B	B	-		-	-	-	-	V5R3
#6204 Differential SCSI Adapter	Y	B	B	B	B	-	-	-	-	---
#6246 1.8m Rack Trim Kit	Y	B	B	B	B	-	-	-	-	V5R3
#6258 36 GB 4 mm Tape Unit	Y	B	B	--	-	-	-	-	-	---
#6279 160 GB VXA-320 Tape Drive	Y	M/B	B	-	-	-	S/B	-	-	V5R3
#6312 Quad Digital Trunk Adapter	Y	B	B	-	-	B	-/B	-	B	---
#6417 HSL-2/RIO-G Bus Adapter	Y	-	-	-	-	M	M	-	-	V5R3
#6574 - 520 Ultra320 SCSI 4-pack	N	B	-	-	-	-	-	-	-	V5R3
#6580 Optional Rack Security Kit	Y	B	B	B	B	-	-	-	-	V5R3
#6585 - Dasd Locking Kit	Y	B	-	-	-	-	-	-	-	V5R3

Feature code and description	CIF	Model or tower								Minimum i5/OS level
		520 (9405/9406)	550	570	595	#5095/#0595	#5074/#5094/#5294	#5088/#0588	#5790	
#6586 Modem Tray for 19-Inch Rack	Y	M/B	B	B	B	-	-	-	-	V5R3
#6587 Model 520 Rear Cover	Y	B	-	-	-	-	-	-	-	V5R3
#6592 550 4-Disk Slot Expansion - Base Ctrl	Y	-	B	-	-	-	-	-	-	V5R3
#6593 550 4-Disk Slot Expansion - PCI-X Ctrl	Y	-	B	-	-	-	-	-	-	V5R3
#6594 - 520 4-Disk Slot Expansion - Base Ctrl	Y	B	-	-	-	-	-	-	-	V5R3
#6800 PCI 1Gbps Ethernet IOA	Y	M/B	B	B	B	B	S/B	B	B	V5R4
#6801 PCI 1Gbps Ethernet UTP IOA	Y	M/B	B	B	B	B	S/B	B	B	V5R4
#6803 PCI WAN for ECS	Y	M/B*	B	B	B	B	S/B	B	B	V5R4
#6804 PCI WAN for ECS (CIM)	Y	M/B*	B	B	B	B	S/B	B	B	V5R4
#6863 System i5 Slim-Line Doors	Y	-	-	-	B	-	-	-	-	V5R3
#6864 System i5 Acoustic Doors	Y	-	-	-	B	-	-	-	-	V5R3
#7140 520 Express Configuration	Y	P/-*	-	-	-	-	-	-	-	V5R3
#7141 520 Express Configuration	Y	P/-*	-	-	-	-	-	-	-	V5R3
#7142 520 Express Configuration	Y	P/-*	-	-	-	-	-	-	-	V5R3
#7143 520 Express Configuration	Y	B/-*	-	-	-	-	-	-	-	V5R3
#7144 520 Express Configuration	Y	P/-*	-	-	-	-	-	-	-	V5R3
#7148 520 Express Configuration	Y	B/-*	-	-	-	-	-	-	-	V5R3
#7152 520 Express Configuration	Y	P/-	-	-	-	-	-	-	-	V5R3
#7154 Standard Edition for #0910	Y	-	P	-	-	-	-	-	-	V5R3
#7155 Enterprise Edition for #0910	Y	-	B	-	-	-	-	-	-	V5R3
#7180 Acoustic Front Door	Y	B*	-	-	-	-	-	-	-	V5R3
#7181 Easy-Access Front Cover	Y	M/B*	-	-	-	-	-	-	-	V5R3
#7182 520 Rack Mount	Y	M/B*	-	-	-	-	-	-	-	V5R3
#7183 550 Rack Mount	Y	-	B	-	-	-	-	-	-	V5R3
#7188 Power Distribution Unit - Side Mount	Y	B	B	B	B	-	-	-	-	V5R3
#7194 Easy-Access Front Cover	Y	-	B	-	-	-	-	-	-	V5R3
#7197 570 Front Bezel	Y	-	-	B	-	-	-	-	-	V5R3
#7198 Adjustable Depth Rack Rails	Y	M/B	-	-	-	-	-	-	-	V5R3
#7199 Acoustic Front Door	Y	-	B	-	-	-	-	-	-	V5R3
#7256 520 Enterprise Enablement	Y	-/B*	-	-	-	-	-	-	-	V5R3
#7257 550 Enterprise Enablement	Y	-	B	-	-	-	-	-	-	V5R3

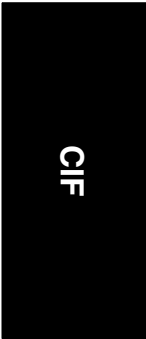

CIF

Feature code and description	CIF	Model or tower								Minimum i5/OS level
		520 (9405/9406)	550	570	595	#5095/#0595	#5074/#5094/#5294	#5088/#0588	#5790	
#7258 570 Full Enterprise Enablement	Y	-	-	B	-	-	-	-	-	V5R3
#7259 595 Full Enterprise Enablement	Y	-	-	-	B	-	-	-	-	V5R3
#7260 570 Enterprise Enablement	Y	-	-	B	-	-	-	-	-	V5R3
#7261 595 Enterprise Enablement	Y	-	-	-	B	-	-	-	-	V5R3
#7307 Dual I/O Unit Enclosure	Y	M/B	B	B	B	-	-	-	-	V5R3
#7320 520 One Processor Activation	Y	-/B*	-	-	-	-	-	-	-	V5R3
#7323 550 One Processor Activation	Y	-	B	-	-	-	-	-	-	V5R3
#7341 550 On/Off Processor Day Billing	Y	-	M	-	-	-	-	-	-	V5R3
#7350 Value Edition for #0975	Y	-/P*	-	-	-	-	-	-	-	V5R3
#7352 Value Edition for #0975	Y	-/B*	-	-	-	-	-	-	-	V5R3
#7354 Accelerator for System i5	Y	M/-*	-	-	-	-	-	-	-	V5R3
#7355 Accelerator for System i5	Y	-/B*	-	-	-	-	-	-	-	V5R3
#7357 Accelerator for System i5	Y	-/B*	-	-	-	-	-	-	-	V5R3
#7366 Solution Edition for #0906	Y	-/P*	-	-	-	-	-	-	-	V5R3
#7373 High Availability Edition for #0906	Y	-/P*	-	-	-	-	-	-	-	V5R3
#7374 High Availability Edition for #0906	Y	-/P	-	-	-	-	-	-	-	V5R3
#7375 High Availability Edition for #0906	Y	-/P*	-	-	-	-	-	-	-	V5R3
#7480 Standard Edition for #0940	Y	-	-	-	B	-	-	-	-	V5R3
#7481 Enterprise Edition for #0940	Y	-	-	-	B	-	-	-	-	V5R3
#7482 Standard Edition for #0941	Y	-	-	-	B	-	-	-	-	V5R3
#7483 Enterprise Edition for #0941	Y	-	-	-	B	-	-	-	-	V5R3
#7486 Standard Edition for #0943	Y	-	-	-	B	-	-	-	-	V5R3
#7487 Enterprise Edition for #0943	Y	-	-	-	B	-	-	-	-	V5R3
#7510 - Quantity of 150 of #4328	Y	B	B	B	B	-	-	-	-	V5R3
#7551 High Availability Edition for #0910	Y	-	P	-	-	-	-	-	-	V5R3
#7580 High Availability Edition for #0940	Y	-	-	-	P	-	-	-	-	V5R3
#7581 High Availability Edition for #0941	Y	-	-	-	P	-	-	-	-	V5R3
#7583 High Availability Edition for #0943	Y	-	-	-	P	-	-	-	-	V5R3
#7590 Capacity BackUp Edition for #0944	Y	-	-	-	B	-	-	-	-	V5R3
#7618 570 One Processor Activation	Y	-	-	B	-	-	-	-	-	V5R3
#7620 520 On/Off Processor Enablement	Y	-/M*	-	-	-	-	-	-	-	V5R3

Feature code and description	CIF	Model or tower								Minimum i5/OS level
		520 (9405/9406)	550	570	595	#5095/#0595	#5074/#5094/#5294	#5088/#0588	#5790	
#7621 520 On/Off Processor Day Billing	Y	-/M*	-	-	-	-	-	-	-	V5R3
#7622 520 Reserve Capacity Prepaid	Y	-/B*	-	-	-	-	-	-	-	V5R3
#7624 570 On/Off Processor Day Billing	Y	-	-	M	-	--	-	-	-	V5R3
#7629 Domino Edition for #0910	Y	-	P	-	-	-	-	-	-	V5R3
#7630 Solution Edition for #0910	Y	-	P	-	-	-	-	-	-	V5R3
#7631 Solution Edition PeopleSoft EnterpriseOne	Y	-	P	-	-	-	-	-	-	V5R3
#7632 C2CRM Solution Edition with Domino	Y	-	P	-	-	-	-	-	-	V5R3
#7640 2-way SAP Solution Edition	Y	-	P	-	-	-	-	-	-	V5R3
#7641 4-way SAP Solution Edition	Y	-	B	-	-	-	-	-	-	V5R3
#7663 570 1GB Memory Activation	Y	-	-	B	-	-	-	-	-	V5R3
#7680 Accelerator for System i5	Y	M/-*	-	-	-	-	-	-	-	V5R3
#7681 Accelerator for System i5	Y	M/-*	-	-	-	-	-	-	-	V5R3
#7682 Accelerator for System i5	Y	M/-*	-	-	-	-	-	-	-	V5R3
#7687 Accelerator for System i5	Y	M/-*	-	-	-	-	-	-	-	V5R3
#7728 570 Reserve Capacity Prepaid	Y	-	-	B	-	-	-	-	-	V5R4
#7734 Enterprise Edition for #0906	Y	-/B*	-	-	-	-	-	-	-	V5R3
#7735 Enterprise Edition for #0906	Y	-/B*	-	-	-	-	-	-	-	V5R3
#7736 Enterprise Edition for #0906	Y	-/B*	-	-	-	-	-	-	-	V5R3
#7738 570 Base Processor Activation	Y	-	-	P	-	-	-	-	-	V5R3
#7741 550 Reserve Capacity Prepaid	Y	-	B	-	-	-	-	-	-	V5R3
#7747 Enterprise Edition for #0934	Y	-	-	B	-	-	-	-	-	V5R3
#7748 Enterprise Edition for #0935	Y	-	-	B	-	-	-	-	-	V5R3
#7749 Enterprise Edition for #0936	Y	-	-	B	-	-	-	-	-	V5R3
#7750 Easy Access Front Cover	Y	B	-	-	-	-	-	-	-	V5R3
#7751 Easy Access Front Cover	Y	-	B	-	-	-	-	-	-	V5R3
#7753 Acoustic Front Door	Y	B	-	-	-	-	-	-	-	V5R3
#7754 Acoustic Front Door	Y	-	B	-	-	-	-	-	-	V5R3
#7757 Standard Edition for #0934	Y	-	-	B	-	-	-	-	-	V5R3
#7758 Standard Edition for #0935	Y	-	-	B	-	-	-	-	-	V5R3
#7759 Standard Edition for #0936	Y	-	-	B	-	-	-	-	-	V5R3
#7760 Capacity BackUp Edition for #0937	Y	-	-	B	-	-	-	-	-	V5R3

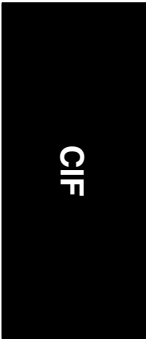

CIF

Feature code and description	CIF	Model or tower								Minimum i5/OS level
		520 (9405/9406)	550	570	595	#5095/#0595	#5074/#5094/#5294	#5088/#0588	#5790	
#7763 High Availability Edition for #0934	Y	-	-	P	-	-	-	-	-	V5R3
#7764 High Availability Edition for #0935	Y	-	-	P	-	-	-	-	-	V5R3
#7765 High Availability Edition for #0936	Y	-	-	P	-	-	-	-	-	V5R3
#7768 CPU Power Regulator	Y	-	-	B	-	-	-	-	-	V5R3
#7784 Standard Edition for #0906	Y	-/B*	-	-	-	-	-	-	-	V5R3
#7785 Standard Edition for #0906	Y	-/B*	-	-	-	-	-	-	-	V5R3
#7798 550 non-IBM Rack Mount	Y	-	PU	-	-	-	-	-	-	V5R3
#7801 - 6m HMC Attachment Cable	Y	B	B	B	B	-	-	-	-	V5R3
#7802 - 15m HMC Attachment Cable	Y	B	B	B	B	-	-	-	-	V5R3
#7815 595 One Processor Activation	Y	-	-	-	B	-	-	-	-	V5R3
#7840 Side-by-side Attach Kit 1.8m Rack	Y	B	B	B	B	-	-	-	-	V5R3
#7841 Ruggedize Rack Kit	Y	B	B	B	B	-	-	-	-	V5R3
#7861 Single Wide Short Blindswap Cassette	Y	N	N	Y	N	N	N	N	N	V5R3
#7862 Single Wide Long Blindswap Cassette	Y	Y	Y	Y	N	N	N	N	Y	V5R3
#7863 Double Wide Long Blindswap Cassette	Y	Y	Y	Y	N	N	N	N	Y	V5R3
#7875 CPU Power Regulator	Y	-	-	B	-	-	-	-	-	V5R3
#7884 520 Rack Mount	Y	PU	-	-	-	-	-	-	-	V5R3
#7885 520 Deskside	Y	PU	-	-	-	-	-	-	-	V5R3
#7886 550 IBM Rack Mount	Y	-	PU	-	-	-	-	-	-	V5R3
#7887 550 Deskside	N	-	PU	-	-	-	-	-	-	V5R3
#7889 550 Redundant Power Supply	Y	-	B	-	-	-	-	-	-	V5R3
#7892 2GB DDR2 Main Storage	N	-	-	B	-	-	-	-	-	V5R3
#7893 4GB DDR2 Main Storage	N	-	-	B	-	-	-	-	-	V5R3
#7894 8GB DDR2 Main Storage	N	-	-	B	-	-	-	-	-	V5R3
#7937 - 595 Bolt-Down (Lo Raised Fl)	N	-	-	-	M	-	-	-	-	V5R3
#7938 - 595 Bolt-Down (Hi Raised Fl)	N	-	-	-	M	-	-	-	-	V5R3
#7939 - 595 Bolt-Down (Non Raised Fl)	N	-	-	-	M	-	-	-	-	V5R3
#7940 Advanced Power Virtualization		B	-	-	-	-	-	-	-	V5R3
#7941 Advanced Power Virtualization		-	B	-	-	-	-	-	-	V5R3
#7942 Advanced Power Virtualization		-	-	B	-	-	-	-	-	V5R3
#7971 595 On/Off Processor Enablement	Y	-	-	-	M	-	-	-	-	V5R3

Feature code and description	CIF	Model or tower								Minimum i5/OS level
		520 (9405/9406)	550	570	595	#5095/#0595	#5074/#5094/#5294	#5088/#0588	#5790	
#7972 595 On/Off Processor Day Billing	Y	-	-	-	M	-	-	-	-	V5R3
#7975 595 Reserve Capacity Prepaid	Y	-	-	-	B	-	-	-	-	V5R3
#7992 Advanced Power Virtualization	Y	-	-	-	B	-	-	-	-	---
#8312 550 1.9 GHz Processor 0/2-way	Y	-	B	-	-	-	-	-	-	V5R3
#8325 520 1.9 GHz Processor	Y	P*	-	-	-	-	-	-	-	V5R3
#8327 520 1.9 GHz Processor	N	B*	-	-	-	-	-	-	-	V5R3
#8330 520 1.9 GHz Processor 0/2-way	N	-/B*	-	-	-	-	-	-	-	V5R3
#8338 570 2.2 GHz Processor 0/2-way	N	-	-	B	-	-	-	-	-	V5R3
#8410 520 Base Processor Activation	Y	-/B*	-	-	-	-	-	-	-	V5R3
#8413 550 Base Processor Activation	Y	-/B*	-	-	-	-	-	-	-	V5R3
#8453 - Base Customer Placement	N	-	-	P	-	-	-	-	-	V5R3
#8457 595 Base Processor Activation	Y	-	-	-	B	-	-	-	-	V5R3
#8470 570 Base 1GB Memory Activation	Y	-	-	B	-	-	-	-	-	V5R3
#8754 Optional Base 50 GB ¼-inch Cartridge Tape Device	Y	B	-	-	-	-	-	-	-	V5R3
#8950 Model 520 Processor	N	P	-	-	-	-	-	-	-	V5R3
#8951 Model 520 Processor	N	B	-	-	-	-	-	-	-	V5R3
#8952 Model 520 Processor	N	B	-	-	-	-	-	-	-	V5R3
#8953 Model 520 Processor	N	B	-	-	-	-	-	-	-	V5R3
#8954 Model 520 Processor	N	B	-	-	-	-	-	-	-	V5R3
#8955 Model 520 2-way Processor	N	P	-	-	-	-	-	-	-	V5R3
#8961 Model 570 CoD 0/2-way Processor	Y	-	-	B	-	-	-	-	-	V5R3
#8966 595 1.9 Ghz Processor 0/16-way	N	-	-	-	B	-	-	-	-	V5R3
#8972 Model 520 Processor	N	-/B	-	-	-	-	-	-	-	V5R3
#9299 Base Enterprise Enablement	Y	-/B*	B	B	B	-	-	-	-	V5R3
#9493 Base PCI WAN for ECS	Y	-/B*	B	B	B	-	-	-	-	V5R4
#9494 Base PCI WAN for ECS (CIM)	Y	-/B*	B	B	B	-	-	-	-	V5R4
#9510 Base Integrated Cache 40MB	Y	P/-*	-	-	-	-	-	-	-	V5R3
#9517 Base HSL-2/RIO-G Bus Adapter	Y	-	-	-	-	B	B	-	-	V5R3
#9531 Base HSL-2/RIO-G Bus Adapter	Y	-	-	-	-	-	-	-	Y	V5R3
#9545 Base 4 GB DDR1 Main Storage	Y	P	-	-	-	-	-	-	-	V5R3

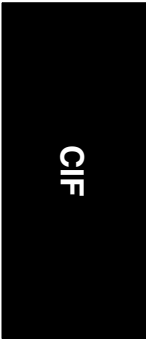

Feature code and description	CIF	Model or tower								Minimum i5/OS level
		520 (9405/9406)	550	570	595	#5095/#0595	#5074/#5094/#5294	#5088/#0588	#5790	
#9548 Base 1GB Main Storage	Y	P/-*	-	-	-	-	-	-	-	V5R3
#9549 Base 2GB Main Storage	Y	P/-*	-	-	-	-	-	-	-	V5R3
#9553 Base 4GB Main Storage	Y	P/-*	-	-	-	-	-	-	-	V5R3
#9570 Reserved Rack Space	Y	-	-	P	-	-	-	-	-	V5R3
#9691 Base Bus Adapter		M	M	M	M	-	Y	-	-	V4R5
#9710 Base PCI Integrated xSeries Server	Y	-	B	B	-	B	B	B	-	V5R3
#9726 Base 512 MB Server Memory	Y	-	-	-	B	B	B	B	-	V5R3
#9771 Base PCI Two-Line WAN with integrated modem	Y	S	S	S	S	-	-	-	-	V5R3
#9793 Two-Line WAN IOA with Modem	Y	B	B	B	B	-	-	-	-	V5R3
#9794 Two-Line IOA with Modem	Y	B	B	B	B	-	-	-	-	V5R3
#9844 Base PCI IOP	Y	B	B	B	B	B	B	-	-	V5R3
#9876 Base Optical Bus Adapter	N	-	B	B	B	-	P	P	-	V5R3
#9877 Base HSL-2 Bus Adapter	N	B	B	B	B	B	B	B	-	V5R3

* i5/OS V5R3 with V5R3M5 LIC on Model 520+ or for #2847 PCI IOP for SAN Load Source needed

5.2 IBM eServer iSeries Models 800, 810, 825, 870, #2497/#2498 890 system unit and tower supported features

The table in this section lists the commonly ordered feature codes for the IBM eServer iSeries models. They identify which features are CIF features, in which model and expansion unit the feature is supported, and the minimum release of i5/OS or OS/400 required to support the feature.

The following table shows the features supported in Models 800, 810, 825, 870, and 890 (#2497 and #2498 processors), and the associated expansion units, the CIF designation, and minimum OS/400 operating system level of each feature.

Refer to Chapter 4, "IBM System i5, eServer i5, and iSeries features and placement" on page 97 to understand the minimum operating system requirements by feature code, and the processors each feature is supported in.

Feature code and description	CIF	Model or tower								Minimum OS/400 level
		800	810	825	870	890	#5095/#0595	#5074/#5094/#5294	#5088 #0588	
#0041 Device Parity Protection-All	Y		B	B	B	B	-	-	-	V5R2
#0092 External xSeries Attach	Y	B	B	B	B	B	-	-	-	V5R2
#0123 #5074 Lower Unit in Rack	Y	-	S	S	S	S	-	-	-	V5R2
#0126 CEC EIA Reduction Option	N	-	-	-	B	B	-	-	-	V5R2
#0133 Plant Install in Rack	Y	B	B	-	-	-	-	-	-	V5R2
#0134 Field Install in Rack (HD)	Y	-	-	B	-	-	-	-	-	V5R2
#0197 Model 890 24-way Processor	N	-	-	-	-	B	-	-	-	V5R2
#0198 Model 890 32-way Processor	N	-	-	-	-	B	-	-	-	V5R2
#0325 IPCS Extension Cables for NT	Y	B	B	B	B	B	B	B	B	V5R2
#0367 Operations Console PCI Cable	Y	B	B	B	B	B	B	B	B	V5R2
#0369 100m Optical SPCN Cable	Y	-	-	B	B	B	B	B	B	V5R2
#0371 LC-SC Adapter Kit (50 um)	Y	B	B	B	B	B	B	B	B	V5R2
#0372 LC-SC Adapter Kit (62.5 um)	Y	B	B	B	B	B	B	B	B	V5R2
#0383 Remote Control Panel Cable	Y	B	B	B	B	B				V5R2
#0426 512 MB Server Memory	N	-	-	B	B	B	B	B	B	V5R2
#0427 1 GB Server Memory	N	-	-	B	B	B	B	B	B	V5R2
#0446 512 MB DDR Server Memory	Y	B	B	-	-	-	B	B	B	V5R2
#0447 1 GB DDR Server Memory	Y	B	B	-	-	-	B	B	B	V5R2
#0531 i5/OS V5R3, V5R3M5 LIC	Y	M	M	M	M	M	-	-	-	V5R3
#0532 i5/OS V5R4, V5R4M0 LIC	Y	M	M	M	M	M	-	-	-	V5R4
#0551 iSeries Rack	Y	B	B	B	B	B	-	-	-	V5R2
#0578 PCI Expansion Unit in Rack	N	-	S	S	S	B	-	-	-	V5R2
#0588 PCI-X Expansion Unit in Rack	N	B	B	B	B	B	-	-	-	V5R2
#0595 PCI-X Expansion Unit in Rack	Y	B	B	B	B	B	-	-	-	V5R2
#0601 - Direct Attach #2743 PCI 1 Gbps Ethernet IOA	Y	-	SC	SC	SC	B	S	S	S	V5R2
#0602 - Direct Attach #2760 PCI 1 Gbps Ethernet UTP IOA	Y	-	SC	SC	SC	B	S	S	S	V5R2
#0603 - Direct Attach #2744 PCI 100 Mbps Token-Ring IOA	Y	B	B	B	B	B	B	B	B	V5R2
#0604 - Direct Attach #2763 PCI RAID Disk Unit Controller	Y	SC	SC	SC	SC	SC	SC	-	-	V5R2

CIF

Feature code and description	CIF	Model or tower								Minimum OS/400 level
		800	810	825	870	890	#5095/#0595	#5074/#5094/#5294	#5088 #0588	
#0605 - Direct Attach #4748 PCI RAID Disk Unit Controller	Y	-	-	SC	SC	SC	S	S	-	V5R2
#0606 - Direct Attach #4778 PCI RAID Disk Unit Controller	Y	-	-	B	B	B	B	B	-	V5R2
#0607 - Direct Attach #4838 PCI 100/10 Mbps Ethernet IOA	Y	-	SC	SC	SC	B	S	S	S	V5R2
#0608 - Direct Attach #4745 PCI WAN IOA	Y	-	SC	SC	SC	SC	S	S	S	V5R2
#0609 - Direct Attach #2772 PCI Dual WAN/Modem IOA	Y	B	B	B	B	B	B	B	B	V5R2
#0610 - Direct Attach #2773 PCI Dual WAN/ModemIOA	Y	B	B	B	B	B	B	B	B	V5R2
#0612 - Direct Attach #2766 PCI Fibre Channel Disk Controller	Y	B	B	B	B	B	B	B	B	V5R2
#0613 - Direct Attach #2742 PCI 2-Line WAN IOA	Y	B	B	B	B	B	B	B	B	V5R2
#0614 - Direct Attach #2793 PCI 2-Line WAN w/Modem	Y	B	B	B	B	B	B	B	B	V5R2
#0615 - Direct Attach #2794 PCI 2-Line WAN w/Modem	Y	B	B	B	B	B	B	B	B	V5R2
#0616 - Direct Attach #2805 PCI Quad Modem IOA	Y	B	B	B	B	B	B	B	B	V5R2
#0617 - Direct Attach #2806 PCI Quad Modem (CIM)	Y	B	B	B	B	B	B	B	B	V5R2
#0618 - Direct Attach #2757 PCI-X Ultra RAID Disk Controller	Y	B	B	B	B	B	B	B	-	V5R2
#0619 - Direct Attach #2782 PCI-X RAID Disk Unit Controller	Y	B	B	B	-	-	B	-	-	V5R2
#0620 - Direct Attach #5700 PCI 1 Gbps Ethernet IOA	Y	B	B	B	B	B	B	B	B	V5R2
#0621 - Direct Attach #5701 PCI 1 Gbps Ethernet UTP IOA	Y	B	B	B	B	B	B	B	B	V5R2
#0623 - Direct Attach #2849 PCI 100/10 Mbps Ethernet IOA	Y	B	B	B	B	B	B	B	B	V5R2
#0624 - Direct Attach #5702 PCI-X Ultra Tape Controller	Y	B	B	B	B	B	B	B	B	V5R2
#0626 - Direct Attach #2787 PCI-X Fibre Channel Disk Controller	Y	B	B	B	B	B	B	B	B	V5R2
#0628 - Direct Attach #5703 PCI-X RAID Disk Unit Controller	Y	B	B	B	B	B	B	B	B	V5R2
#0647 PCI-X Disk/Tape Controller without IOP	Y	M	M	M	M	M	B	S/B	B	---

Feature code and description	CIF	Model or tower								Minimum OS/400 level
		800	810	825	870	890	#5095/#0595	#5074/#5094/#5294	#5088 #0588	
#0648 PCI-X Disk Controller 90MB without IOP	Y	M	M	M	M	M	B	S/B	B	---
#0694 - #5094 Equivalent	Y	-	-	-	-	-	-	B	-	V5R2
#1460 3m Copper HSL Cable	Y	B	B	B	-	-	-	-	-	V5R2
#1461 6m Copper HSL Cable	Y	B	B	B	-	-	-	-	-	V5R2
#1462 15m Copper HSL Cable	Y	B	B	B	-	-	-	-	-	V5R2
#1463 2m SPCN Cable	Y	B	B	B	B	B	B	B	B	V5R2
#1464 6m SPCN Cable	Y	B	B	B	B	B	B	B	B	V5R2
#1465 15m SPCN Cable	Y	B	B	B	B	B	B	B	B	V5R2
#1466 30m SPCN Cable	Y	B	B	B	B	B	B	B	B	V5R2
#1468 250m Optical SPCN Cable	Y	-	-	B	B	B	B	B	B	V5R2
#1470 6m Optical HSL Cable	Y	-	-	B	B	B	B	B	B	V5R2
#1471 30m Optical HSL Cable	Y	-	-	B	B	B	B	B	B	V5R2
#1472 100m Optical HSL Cable	Y	-	-	B	B	B	B	B	B	V5R2
#1473 250m Optical HSL Cable	Y	-	-	B	B	B	B	B	B	V5R2
#1474 6m HSL to HSL-2 Cable	Y	B	B	B	B	B	B	B	B	V5R2
#1475 10m HSL to HSL-2 Cable	Y	B	B	B	B	B	B	B	B	V5R2
#1476 4.3m 200V/12A Power Cd U.K.	Y	-	-	-	-	-	-	B	-	V5R2
#1482 3.5m HSL-2 Cable	Y	-	-	B	B	B	-	B	B	V5R2
#1483 10m HSL-2 Cable	Y	-	-	B	B	B	-	B	B	V5R2
#1485 15m HSL-2 Cable	Y	-	-	B	B	B	-	B	B	V5R2
#1576 5250 CPW Capacity Card	N	-	-	-	-	PU	-	-	-	V5R2
#1577 5250 CPW Capacity Card	N	-	-	-	-	B	-	-	-	V5R2
#1578 5250 CPW Capacity Card	N	-	-	-	-	B	-	-	-	V5R2
#1579 5250 CPW Capacity Card	N	-	-	-	-	B	-	-	-	V5R2
#1581 5250 CPW Capacity Card	N	-	-	-	-	B	-	-	-	V5R2
#1583 5250 CPW Capacity Card	N	-	-	-	-	B	-	-	-	V5R2
#1585 5250 CPW Capacity Card	N	-	-	-	-	B	-	-	-	V5R2
#1587 5250 CPW Capacity Card	N	-	-	-	-	B	-	-	-	V5R2
#1588 5250 CPW Capacity Card	N	-	-	-	-	B	-	-	-	V5R2
#1591 5250 CPW Capacity Card	N	-	-	-	-	B	-	-	-	V5R2
#1609 825 CUoD Activation	Y	-	-	B	-	-	-	-	-	V5R2

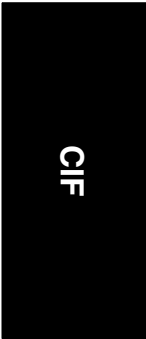

CIF

Feature code and description	CIF	Model or tower								Minimum OS/400 level
		800	810	825	870	890	#5095/#0595	#5074/#5094/#5294	#5088 #0588	
#1610 890 CUoD Activation	Y	-	-	-	-	B	-	-	-	V5R2
#1611 870 CUoD Activation	Y	-	-	-	B	-	-	-	-	V5R2
#1612 890 CUoD Activation	Y	-	-	-	-	B	-	-	-	V5R2
#1613 890 CUoD Activation	Y	-	-	-	-	B	-	-	-	V5R2
#1700 IPCS Keyboard or Mouse for NT	Y	B	B	B	B	B	B	B	B	V5R2
#1773 TCoD Enablement for Mod 825	Y	-	-	M	-	-	-	-	-	V5R2
#1776 TCoD Enablement for Mod 870	Y	-	-	-	M	-	-	-	-	V5R2
#1777 TCoD Enablement for Mod 890	Y	-	-	-	-	M	-	-	-	V5R2
#1778 TCoD Enablement for Mod 890	Y	-	-	-	-	M	-	-	-	V5R2
#2463 Model 800 Processor	N	P	-	-	-	-	-	-	-	V5R2
#2464 Model 800 Processor	N	B	-	-	-	-	-	-	-	V5R2
#2465 Model 810 Processor	N	-	B	-	-	-	-	-	-	V5R2
#2466 Model 810 Processor	N	-	B	-	-	-	-	-	-	V5R2
#2467 Model 810 Processor	N	-	B	-	-	-	-	-	-	V5R2
#2469 Model 810 2-way Processor	N	-	B	-	-	-	-	-	-	V5R2
#2473 Model 825 3/6-Way POD Processor	N	-	-	B	-	-	-	-	-	V5R2
#2486 Model 870 8/16-way Processor	N	-	-	-	B	-	-	-	-	V5R2
#2487 Model 890 16/24-way Processor	N	-	-	-	-	B	-	-	-	V5R2
#2488 Model 890 24/32-way Processor	N	-	-	-	-	B	-	-	-	V5R2
#2497 Model 890 16/24-way Processor	N	-	-	-	-	B	-	-	-	V5R2
#2498 Model 890 24/32-way Processor	N	-	-	-	-	B	-	-	-	V5R2
#2738 HSL Ports - 8 Copper	N	-	-	M	M	M	-	-	-	V5R2
#2739 Optical Bus Adapter	N	-	-	-	-	-	-	-	-	V5R2
#2742 Two-Line WAN IOA	Y	B	B	B	B	B	B	B	B	V5R2
#2743 1 Gbps PCI Ethernet IOA	Y	-	S	S	S	B	S	S	S	V5R2
#2744 PCI 100 Mbps Token Ring IOA	Y	B	B	B	B	B	B	B	B	V5R2
#2749 PCI Ultra Magnetic Media Controller	Y	B	B	B	B	B	B	B	B	V5R2
#2757 PCI-X Ultra RAID Disk Controller	Y	B	B	B	B	B	B	B	-	V5R2
#2760 PCI 1 Gbps Ethernet UTP Adapter	Y	-	S	S	S	S	S	S	S	V5R2
#2763 PCI RAID Disk Unit Controller	Y	-	SC	SC	SC	SC	SC	-	-	V5R2
#2765 PCI Fibre Channel Tape Controller	Y	B	B	B	B	B	B	B	B	V5R2

Feature code and description	CIF	Model or tower								Minimum OS/400 level
		800	810	825	870	890	#5095/#0595	#5074/#5094/#5294	#5088 #0588	
#2766 PCI Fibre Channel Disk Controller	Y	B	B	B	B	B	B	B	B	V5R2
#2768 PCI Magnetic Media Controller	Y	-	S	S	S	B	S	S	S	V5R2
#2772 PCI Dual WAN/Modem IOA	Y	B	B	B	B	B	B	B	B	V5R2
#2773 PCI Dual WAN/Modem IOA	Y	B	B	B	B	B	B	B	B	V5R2
#2776 HSL-2 Ports - 8 Copper	N	-	-	-	B	B	-	-	-	V5R2
#2780 PCI-X Ultra4 RAID Disk Ctrl		B	B	B	B	B	B	B		V5R2
#2782 PCI-X RAID Disk Unit Controller	Y	B	B	B	-	-	B	-	-	V5R2
#2785 HSL-2 Ports - 2 Copper	Y	-	-	B	-	-	-	-	-	V5R2
#2786 HSL Ports - 2 Optical	Y	-	-	B	-	-	-	-	-	V5R2
#2787 PCI-X Fibre Channel Disk Controller	Y	B	B	B	B	B	B	B	B	V5R2
#2788 HSL Ports - 8 Optical	N	-	-	-	B	B	-	-	-	V5R2
#2790 PCI Integrated Netfinity Server	N	-	-	S	S	S	S	S	S	V5R2
#2791 PCI Integrated xSeries Server	N	-	-	S	S	S	S	S	S	V5R2
#2792 PCI Integrated xSeries Server	N	-	-	B	B	B	B	B	B	V5R2
#2793 Two-Line WAN IOA with Modem	Y	B	B	B	B	B	B	B	B	V5R2
#2794 Two-Line WAN IOA with Modem	Y	B	B	B	B	B	B	B	B	V5R2
#2795 128 MB Server Memory	N	-	-	M	M	B	M	M	M	V5R2
#2796 256 MB Server Memory	N	-	-	M	M	B	M	M	M	V5R2
#2797 1 GB Server Memory	N	-	-	M	M	B	M	M	M	V5R2
#2799 PCI Integrated xSeries Server	N	-	-	S	S	B	S	S	S	V5R2
#2805 PCI Quad Modem IOA	Y	B	B	B	B	B	B	B	B	V5R2
#2806 PCI Quad Modem (CIM)	Y	B	B	B	B	B	B	B	B	V5R2
#2817 PCI 155 Mbps MMF ATM IOA	Y	-	S	S	S	S	S	S	S	V5R2
#2842 PCI IOP	Y	-	S	-	-	-	S	-	-	V5R2
#2843 PCI IOP	Y	-	S	S	S	B	S	S	S	V5R2
#2844 PCI IOP	Y	B	B	B	B	B	B	B	B	V5R2
#2849 10/100 Mbps Ethernet Adapter	Y	B	B	B	B	B	B	B	B	V5R2
#2886 Optical Bus Adapter	Y	-	-	-	-	-	M	M	M	V5R2
#2887 HSL-2 Bus Adapter	Y	-	-	-	-	-	M	M	M	V5R2
#2890 PCI Integrated Netfinity Server	Y	-	SC	-	-	-	S	S	S	V5R2
#2891 PCI Integrated xSeries Server	Y	-	SC	-	-	-	S	S	S	V5R2

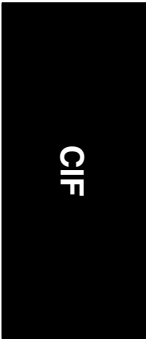

Feature code and description	CIF	Model or tower								Minimum OS/400 level
		800	810	825	870	890	#5095/#0595	#5074/#5094/#5294	#5088 #0588	
#2892 PCI Integrated xSeries Server	Y	B	B	-	-	-	B	B	B	V5R2
#2895 128 MB Server Memory	Y	-	M	-	-	-	M	M	M	V5R2
#2896 256 MB Server Memory	Y	-	M	-	-	-	M	M	M	V5R2
#2897 1 GB Server Memory	Y	-	M	-	-	-	M	M	M	V5R2
#2899 PCI Integrated xSeries Server	Y	-	SC	-	-	-	S	S	S	V5R2
#3015 8 GB Main Storage	N	-	-	-	B	B	-	-	-	V5R2
#3016 8 GB Main Storage	N	-	-	-	-	B	-	-	-	V5R2
#3017 32 GB Main Storage	N	-	-	-	B	B	-	-	-	V5R2
#3018 32 GB Main Storage	N	-	-	-	-	B	-	-	-	V5R2
#3020 4 GB Main Storage	N	-	-	-	B	B	-	-	-	V5R2
#3021 4 GB Main Storage	N	-	-	-	-	B	-	-	-	V5R2
#3022 128 MB Main Storage	Y	-	M	-	-	-	-	-	-	V5R2
#3024 256 MB Main Storage	Y	-	B	-	-	-	-	-	-	V5R2
#3025 512 MB Main Storage	Y	-	S	-	-	-	-	-	-	V5R2
#3026 512 MB Main Storage	Y	-	B	-	-	-	-	-	-	V5R2
#3027 1 GB Main Storage	Y	-	B	-	-	-	-	-	-	V5R2
#3029 128 MB Main Storage	Y	-	B	-	-	-	-	-	-	V5R2
#3035 16 GB Main Storage	N	-	-	-	B	B	-	-	-	V5R2
#3036 16 GB Main Storage	N	-	-	-	-	B	-	-	-	V5R2
#3042 256 MB Main Storage	Y	-	-	B	-	-	-	-	-	V5R2
#3043 512 MB Main Storage	Y	-	-	B	-	-	-	-	-	V5R2
#3044 1024 MB Main Storage	Y	-	-	B	-	-	-	-	-	V5R2
#3045 1024 MB Main Storage	Y	-	-	B	-	-	-	-	-	V5R2
#3046 2048 MB Main Storage	Y	-	-	B	-	-	-	-	-	V5R2
#3092 256 MB Main Storage	Y	B	B	-	-	-	-	-	-	V5R2
#3093 512 MB Main Storage	Y	B	B	-	-	-	-	-	-	V5R2
#3094 1024 MB Main Storage	Y	B	B	-	-	-	-	-	-	V5R2
#3095 1024 MB Main Storage	Y	B	B	-	-	-	-	-	-	V5R2
#3096 2048 MB Main Storage	Y	B	B	-	-	-	-	-	-	V5R2
#4308 4.19 GB Disk Unit	Y	-	-	-	-	-	-	S	-	V5R2
#4314 8.58 GB Disk Unit	Y	-	S	S	S	S	S	S	-	V5R2

Feature code and description	CIF	Model or tower								Minimum OS/400 level
		800	810	825	870	890	#5095/#0595	#5074/#5094/#5294	#5088 #0588	
#4317 8.58 GB 10k RPM Disk Unit	Y	-	SC	SC	SC	SC	S	S	-	V5R2
#4318 17.54 GB 10k RPM Disk Unit	Y	B	B	B	B	B	B	B	-	V5R2
#4319 35.16 GB 10k RPM Disk Unit	Y	B	B	B	B	B	B	B	-	V5R2
#4324 17.54 GB Disk Unit	Y	-	S	S	S	S	S	S	-	V5R2
#4326 35.16 GB 15k RPM Disk Unit	Y	B	B	B	B	B	B	B	-	V5R2
#4327 70.56 GB 15k RPM Disk Unit	Y	B	B	B	B	B	B	B	-	V5R2
#4425 CD-ROM	Y	-	-	-	S	S	-	S	-	V5R2
#4430 DVD-RAM	Y	-	-	-	S	B	-	S	-	V5R2
#4482 4GB ¼-inch Cartridge Tape Device	Y	-	-	-	S	B	-	S	-	V5R2
#4483 16 GB ¼-inch Cartridge Tape Device	Y	-	-	-	S	S	-	S	-	V5R2
#4486 25 GB ¼-inch Cartridge Tape Device	Y	-	-	-	S	S	-	S	-	V5R2
#4487 50 GB ¼-inch Cartridge Tape Device	Y	-	-	-	S	B	-	S	-	V5R2
#4525 CD-ROM	Y	-	SC	-	-	-	-	-	-	V5R2
#4530 DVD-RAM	Y	B	B	-	-	-	-	-	-	V5R2
#4531 DVD-ROM	Y	B	B	-	-	-	-	-	-	V5R2
#4533 DVD-RAM	Y	B	B	-	-	-	-	-	-	V5R2
#4582 4 GB ¼-inch Cartridge Tape Device	Y	B	B	-	-	-	-	-	-	V5R2
#4583 16 GB ¼-inch Cartridge Tape Device	Y	-	SC	-	-	-	-	-	-	V5R2
#4584 30 GB ¼-inch Cartridge Tape Device	Y	B	B	-	-	-	-	-	-	V5R2
#4585 80 GB VXA-2 Tape Device	Y	B	B	-	-	-	-	-	-	V5R2
#4586 25 GB ¼-inch Cartridge Tape Device	Y	-	SC	-	-	-	-	-	-	V5R2
#4587 50 GB ¼-inch Cartridge Tape Device	Y	B	B	-	-	-	-	-	-	V5R2
#4625 CD-ROM	Y	-	-	SC	SC	SC	-	SC	-	V5R2
#4630 DVD-RAM	Y	-	-	B	B	B	-	B	-	V5R2
#4631 DVD-ROM	Y	-	-	B	B	B	-	B	-	V5R2
#4633 DVD-RAM	Y	-	-	B	B	B	-	B	-	V5R2
#4682 4 GB ¼-inch Cartridge Tape Device	Y	-	-	B	B	B	-	B	-	V5R2
#4684 30 GB ¼-inch Cartridge Tape Device	Y	-	-	B	B	B	-	B	-	V5R2
#4685 80 GB VXA-2 Tape Device	Y	-	-	B	B	B	-	B	-	V5R2
#4686 25 GB ¼-inch Cartridge Tape Device	Y	-	-	SC	SC	SC	-	SC	-	V5R2
#4687 50 GB ¼-inch Cartridge Tape Device	Y	-	-	B	B	B	-	B	-	V5R2

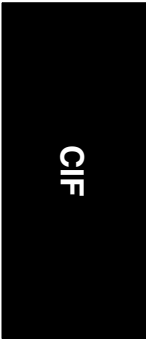

CIF

Feature code and description	CIF	Model or tower								Minimum OS/400 level
		800	810	825	870	890	#5095/#0595	#5074/#5094/#5294	#5088 #0588	
#4723 PCI 10 Mbps Ethernet Adapter	Y	-	SC	SC	SC	SC	S	S	S	V5R2
#4745 PCI 2-line WAN IOA	Y	-	S	S	S	B	S	S	S	V5R2
#4746 PCI Twinaxial IOA	Y	B	B	B	B	B	B	B	B	V5R2
#4748 PCI RAID Disk Unit Controller	Y	-	SC	SC	SC	SC	SC	SC	-	V5R2
#4778 PCI RAID Disk Unit Controller	Y	B	B	B	B	B	B	B	-	V5R2
#4801 PCI Cryptographic Coprocessor	Y	B	B	B	B	B	B	B	B	V5R2
#4810 PCI Integrated xSeries Server	Y	B	B	-	-	-	B	S/B	B	V5R2
#4805 PCI Cryptographic Accelerator	Y	B	B	B	B	B	B	B	B	V5R2
#4815 PCI ATM 155 Mbps UTP OC3	Y	-	SC	SC	SC	SC	S	S	S	V5R2
#4816 PCI ATM 155 Mbps MMF	Y	-	SC	SC	SC	SC	S	S	S	V5R2
#4818 PCI ATM 155 Mbps SMF OC3	Y	-	SC	SC	SC	SC	S	S	S	V5R2
#4838 PCI 100/10 Mbps Ethernet IOA	Y	-	SC	SC	SC	B	SC	SC	SC	V5R2
#5074 PCI Expansion Tower	Y	-	SC	SC	SC	B	-	-	-	V5R2
#5075 PCI Expansion Tower	Y	-	S	S	-	-	-	-	-	V5R2
#5078 PCI Expansion Unit	N	-	-	-	-	-	-	S	-	V5R2
#5079 1.8 m I/O Tower	Y	-	SC	SC	SC	B	-	-	-	V5R2
#5088 PCI-X Expansion Unit	N	-	-	-	B	B	-	B	-	V5R2
#5094 PCI-X Expansion Tower	Y	B	B	B	B	B	-	-	-	V5R2
#5095 PCI-X Expansion Tower	Y	B	B	B	B	B	-	-	-	V5R2
#5107 30 Disk Expansion	N	-	-	-	B	B	-	-	-	V5R2
#5108 30 Disk Expansion Feature	N	-	-	-	-	-	-	B	-	V5R2
#5111 30 Disk Expansion with Dual Line Cords	N	-	-	-	-	-	-	-	-	V5R2
#5114 Dual Line Cords Tower	N	-	-	-	B	B	-	-	-	V5R2
#5115 Dual Line Cords Tower	Y	-	-	-	B	B	-	B	-	V5R2
#5116 Dual Line Cords - 5294 Tower	Y	-	-	-	-	-	-	B	-	V5R2
#5138 Redundant Power and Cooling	Y	-	-	-	-	-	B	-	-	V5R2
#5160 Power Dist Unit 1 Phase NEMA	N	B	B	B	B	B	-	-	-	V5R2
#5161 Power Distribution Unit	N	B	B	B	B	B	-	-	-	V5R2
#5162 Power Distribution Unit	N	B	B	B	B	B	-	-	-	V5R2
#5294 1.8m I/O Tower	Y	-	B	B	B	B	-	-	-	V5R2

Feature code and description	CIF	Model or tower								Minimum OS/400 level
		800	810	825	870	890	#5095/#0595	#5074/#5094/#5294	#5088 #0588	
#5540 System Console on Twinaxial Workstation IOA	Y	B	B	B	B	B	-	-	-	V5R2
#5544 System Console on Operations Console	Y	B	B	B	B	B	-	-	-	V5R2
#5546 System Console on 100 Mbps Token Ring	Y	B	B	-	B	B	-	-	-	V5R2
#5548 System Console on 100 Mbps Ethernet	Y	B	B	B	B	B	-	-	-	V5R2
#5580 - #2780 Controller with Auxiliary Write Cache	Y	B	B	B	B	B	B	S/B	-	V5R2
#5581 - #2757 Controller with Auxiliary Write Cache	Y	B	B	B	B	B	B	S/B	-	V5R2
#5700 PCI 1 Gbps Ethernet IOA	Y	B	B	B	B	B	B	B	B	V5R2
#5701 PCI 1 Gbps Ethernet UTP IOA	Y	B	B	B	B	B	B	B	B	V5R2
#5702 PCI-X Ultra Tape Controller	Y	B	B	B	B	B	B	B	B	V5R2
#5703 PCI-X Tape/DASD Controller	Y	B	B	B	B	B	B	B	B	V5R2
#5705 PCI-X Tape/DASD Controller	Y	P	B	-	-	-	-	-	-	V5R2
#5736 PCI-X Disk/Tape Controller with IOP	Y	M	M	M	M	M	B	S/B	B	V5R3
#5737 PCI-X Disk Controller 90MB with IOP	Y	M	M	M	M	M	B	S/B	B	V5R3
#5760 PCI-X Fibre Channel Disk Controller	Y	M/B	B	B	B	B	B	S/B	B	V5R3
#5761 PCI-X Fibre Channel Tape Controller	Y	M/B	B	B	B	B	B	S/B	B	V5R3
#5766 PCI-X Tape Controller	Y	M	M	M	M	M	B	S/B	B	V5R3
#7002 HSL Enabler	Y	B	-	-	-	-	-	-	-	V5R2
#7116 System Unit Expansion	Y	B	B	-	-	-	-	-	-	V5R2
#7124 DASD Expansion Unit - 5 slot	Y	-	-	B	-	-	-	-	-	V5R2
#7136 DASD Expansion Unit - 6 slot	Y	B	B	-	-	-	-	-	-	V5R2
#7137 DASD Concurrent Maintenance Cage	Y	B	-	-	-	-	-	-	-	V5R2
#7188 Power Dist Unit - Side Mount	Y	B	B	B	B	B	-	-	-	V5R2
#8093 Optional 1.8 m I/O Rack	N	-	-	-	-	PU	-	-	-	V5R2
#8094 Optional 1.8 m I/O Rack	N	-	-	-	PU	PU	-	-	-	V5R2
#9079 Base I/O Tower	N	-	-	-	SC	SC	-	-	-	V5R2
#9094 Base PCI I/O Enclosure	N	-	-	-	PU	PU	-	-	-	V5R2
#9603 POD Activation	N	-	-	-	P	P	-	-	-	V5R2
#9691 Base Bus Adapter		-	-	-	-	-	-	P/-	-	V4R5
#9726 Base 512 MB Server Memory	Y	-	-	PU	PU	PU	PU	PU	PU	V5R2

CIF

Feature code and description	CIF	Model or tower								Minimum OS/400 level
		800	810	825	870	890	#5095/#0595	#5074/#5094/#5294	#5088 #0588	
#9730 Base HSL-2 Ports - 4 Copper	Y	-	-	-	PU	PU	-	-	-	V5R2
#9746 Base PCI Twinax Workstation IOA	Y	P	-	-	-	-	P	P	P	V5R2
#9749 Base PCI 100/10 Ethernet IOA	Y	P	-	-	-	-	P	P	P	V5R2
#9771 Base PCI Two-Line WAN with integrated modem	Y	P	PU	PU	PU	PU	-	-	-	V5R2
#9785 Base HSL-2 Ports - 2 Copper	Y	-	-	PU	-	-	-	-	-	V5R2
#9786 Base HSL Ports - 2 Optical	Y	-	-	PU	-	-	-	-	-	V5R2
#9787 Base HSL-2 Ports - 2 Copper	N	-	-	B	-	-	-	-	-	V5R2
#9789 Base HSL Ports - 4 Optical	Y	-	-	-	-	PU	-	-	-	V5R2
#9792 Base PCI Integrated xSeries Server	Y	-	-	PU	PU	PU	PU	PU	PU	V5R2
#9793 Two-Line WAN IOA with Modem	Y	P	PU	PU	PU	PU	-	-	-	V5R2
#9794 Two-Line IOA with Modem	Y	P	PU	PU	PU	PU	-	-	-	V5R2
#9844 Base PCI IOP	Y	-	-	PU	PU	PU	B	B	-	V5R2
#9886 Base Optical Bus Adapter	Y	-	-	-	-	-	B	B	B	V5R2
#9887 Base HSL-2 Bus Adapter	Y	-	-	-	B	B	B	B	B	V5R2
#9943 Base PCI IOP	Y	-	-	-	-	B	-	-	-	V5R2

System i5, eServer i5 and iSeries towers schematics

This chapter identifies the system diagrams for the towers that are supported by the IBM System i5, eServer i5 and iSeries servers, and the power and packaging features for those towers. IBM System i5, eServer i5 and iSeries Models 800, 810, 825, 870, and 890 do not support System Products Division (SPD) towers and expansion units or migration towers. When upgrading from earlier models to these models, it is necessary to plan for the loss of towers and input/output processors (IOPs) and input/output adapters (IOAs) that are not supported on the later systems.

The tower schematics might have a shaded card slot showing a base IOP. A base IOP might not be included in the tower. See “#9844 Inclusion Rules” on page 174 for the list of criteria allowing the inclusion of a base IOP.

Refer to the following publications for an explanation of RIO-G configuration rules and placement considerations:

- ▶ *IBM eServer iSeries Migration: A Guide to Upgrades and Migrations to POWER Technology*, SG24-7200

This redbook also contains configuration rules for IBM System i5 and eServer i5 models and towers.

- ▶ *IBM eServer iSeries Migration: System Migration and Upgrades at V5R1 and V5R2*, SG24-6055

This redbook also contains configuration rules for iSeries models and towers.

- ▶ *DB2 UDB for OS/390 and Continuous Availability*, SG24-5486, i5/OS V5R4
- ▶ *IBM eServer i5 and iSeries System Handbook i5/OS Version 5 Release 3 October 2005 - Draft*, GA19-5486, OS/400 V5R3
- ▶ *High-speed Link Loop Architecture for the IBM eServer iSeries Server: OS/400 Version 5 Release 2*, REDP-3652
- ▶ V5R3 HSL Presentation 22 November 2005 at:
http://www-03.ibm.com/servers/eserver/series/ha/pdf/V5R3_HSL_Rules.pdf

For further Information use the following resources.

► http://publib.boulder.ibm.com/infocenter/eserver/v1r2s/en_US/index.htm

Model	General availability	Withdrawn from marketing
#0578 PCI Expansion Unit in Rack	23 April 2001	01 October 2004
#0588 PCI-X Expansion Unit in Rack	28 February 2003	01 June 2006
#0595 PCI-X Expansion Unit in Rack	28 February 2003	---
#5074 PCI Expansion Tower	12 June 2000	01 October 2005
#5075 PCI Expansion Tower	12 June 2000	21 November 2003
#5078 PCI Expansion Unit	23 April 2001	01 October 2004
#5079 1.8 m I/O Tower	12 June 2000	01 October 2005
#5088 PCI-X Expansion Unit	28 February 2003	01 June 2006
#5094 PCI-X Expansion Tower	28 February 2003	---
#5095 PCI-X Expansion Tower	28 February 2003	---
#5097 1.8m I/O RACK	July 2004	01 October 2005
#5294 1.8m I/O Tower	28 February 2003	---
#5790 PCI Expansion Drawer	15 October 2004	---
#8093 Optional 1.8 m I/O Rack	14 May 2002	07 May 2003
#8094 Optional 1.8 m I/O Rack	28 February 2003	01 October 2005
#8294 Optional Base 1.8m Rack	15 October 2004	---
#9057 Storage Expansion Unit	19 August 1997	01 January 2004
#9074 Base I/O Tower	12 June 2000	January 2004
#9079 Base I/O Tower	12 June 2000	October 2004
#9094 Base PCI I/O Enclosure	14 May 2002	01 October 2005
#9194 Base PCI-X Expansion Tower	15 October 2004	---

Note: The darker shaded areas in the following tables and graphics indicate the base features.

6.1 System i towers, racks, and expansion unit schematics

This section shows schematics of the towers, racks, and expansion units supported by the System i models represented in this IBM Redbook.

6.1.1 #5074 PCI Expansion Tower

The #5074 PCI Expansion Tower is supported by Models 520, 550, 570, 595 810, 820, 825, 830, 840, SB2, SB3, 870 and 890.

Note: The total number of disk bays is 45.

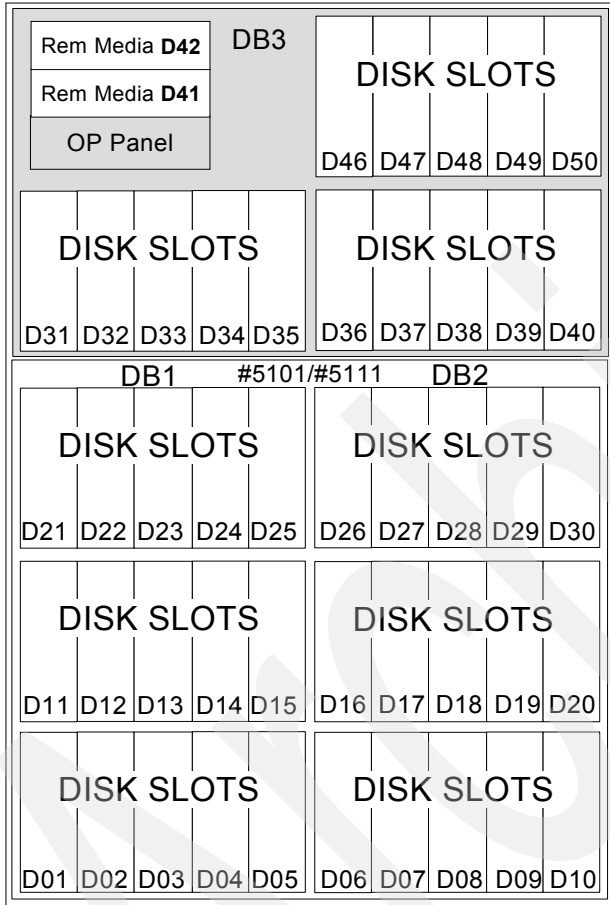

Front

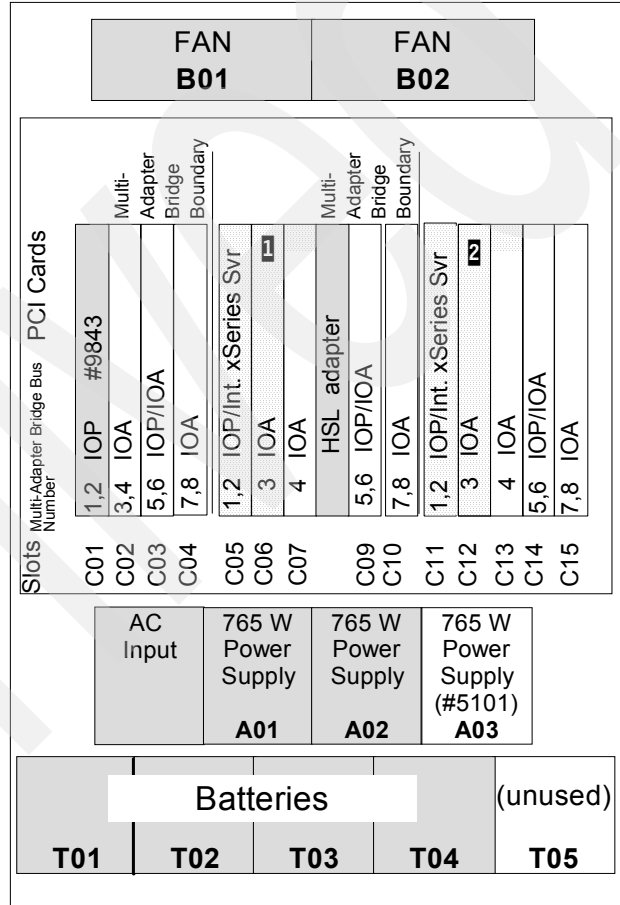

Back

Legend

- Base Feature
- Required Feature
- Unavailable if Integrated xSeries Server is installed

Note 1: If C05 has an Integrated xSeries Server, slot C06 is unavailable, and slot C07 is available only as a short slot.

Note 2: If C11 has an Integrated xSeries Server, slot C12 is unavailable, and slot C13 is available only as a short slot.

Note 3: #5700/#5701 must be placed in a 32-bit slot.

Tower Schematics

6.1.3 #5078/#0578 PCI Expansion Unit

The #5078 PCI Expansion Unit or #0578 PCI Expansion Unit in Rack is attached to the top of a #5074 PCI Expansion Tower or #9079 Base I/O Tower. It can also be mounted in an #0551 iSeries Rack.

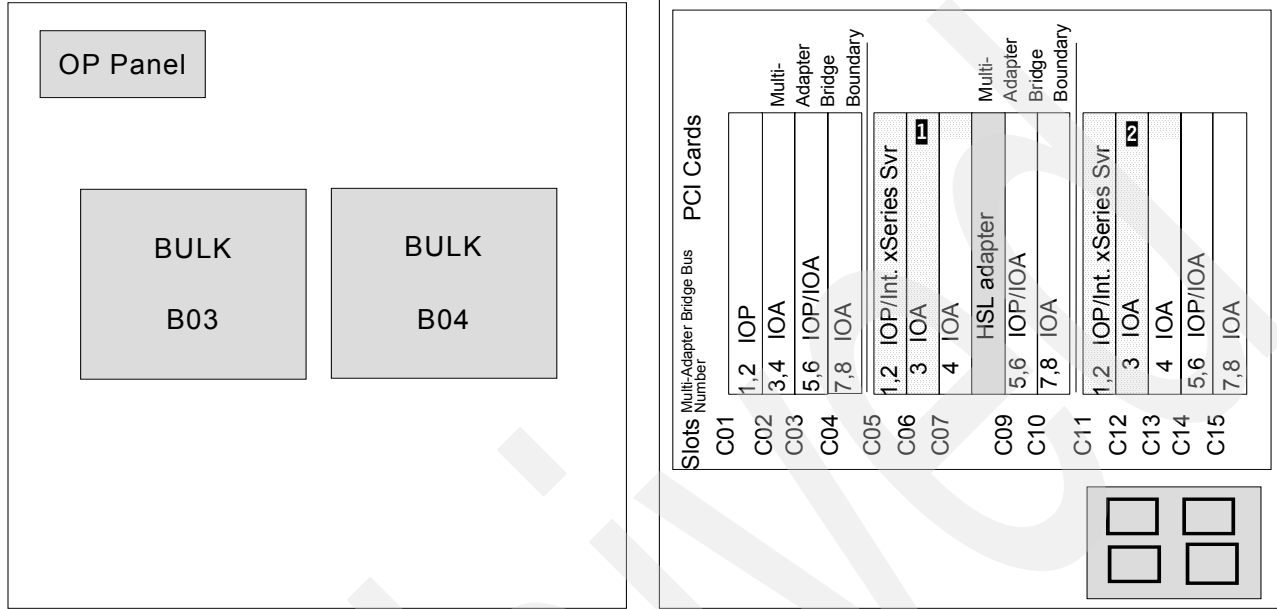

Front

Back

Legend

Base Feature

Required Feature

Unavailable if Integrated xSeries Server is installed

Note 1: If C05 has an Integrated xSeries Server, slot C06 is unavailable, and slot C07 is available only as a short slot.

Note 2: If C11 has an Integrated xSeries Server, slot C12 is unavailable, and slot C13 is available only as a short slot.

Note 3: If #5700/#5701 is installed in C01 then move Disk IOA to next available slot.

Restriction: #5700/#5701 must be placed in a 32-bit slot

6.1.4 #5079 1.8 m I/O Tower

The #5079 1.8 m I/O Tower is supported by Models 520, 570, 595, 810, 820, 825, 830, 840, 870, and 890. The #5079 consists of two #5074 PCI Expansion Towers with side covers and casters removed.

Note: Total number of disk bays is 2 x 45

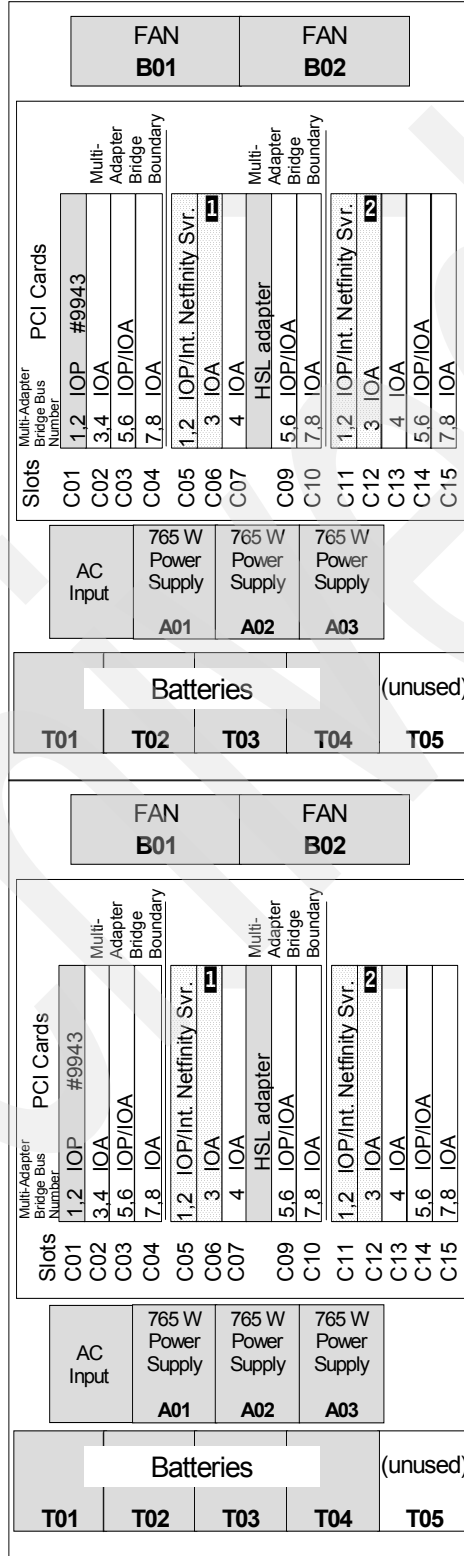
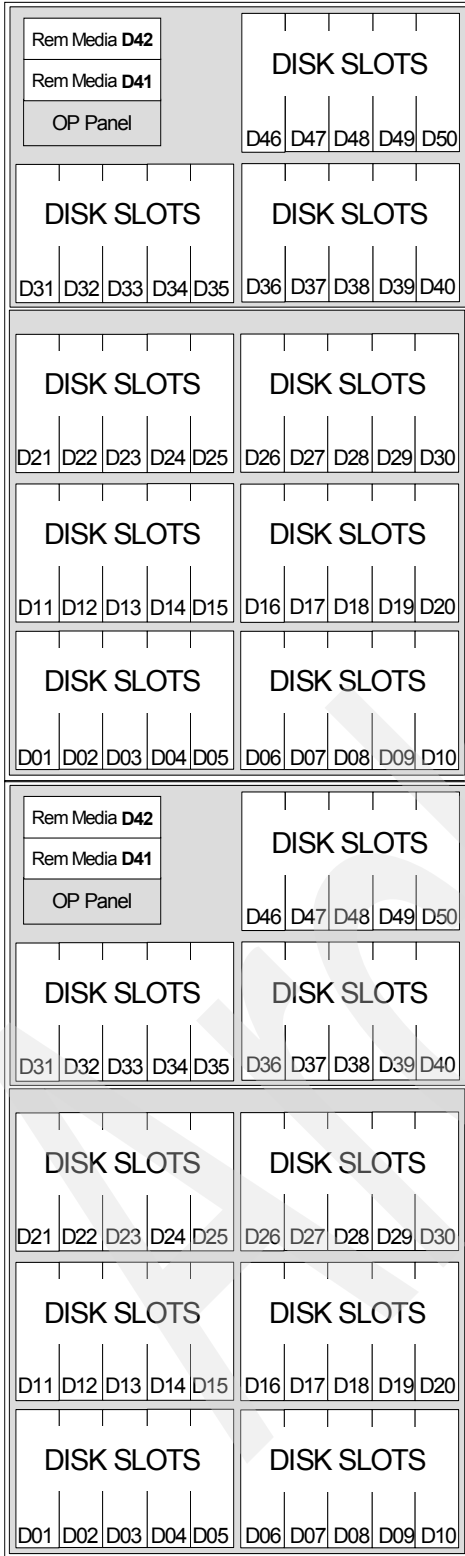

Legend

- Base Feature
- Required Feature
- Unavailable if Integrated Netfinity Server is installed

Note 1: If C05 has an Integrated Netfinity Server, slot C06 is unavailable, and slot C07 is available only as a short slot.

Note 2: If C11 has an Integrated Netfinity Server, slot C12 is unavailable, and slot C13 is available only as a short slot.

6.1.5 #5088/#0588 PCI-X Expansion Unit

The #5088 PCI-X Expansion Unit is attached to the top of a #5074 PCI Expansion Tower, #5094 PCI-X Expansion Tower, or #9094 Base PCI I/O Enclosure. The #0588 is mounted in an #0551 iSeries Rack.

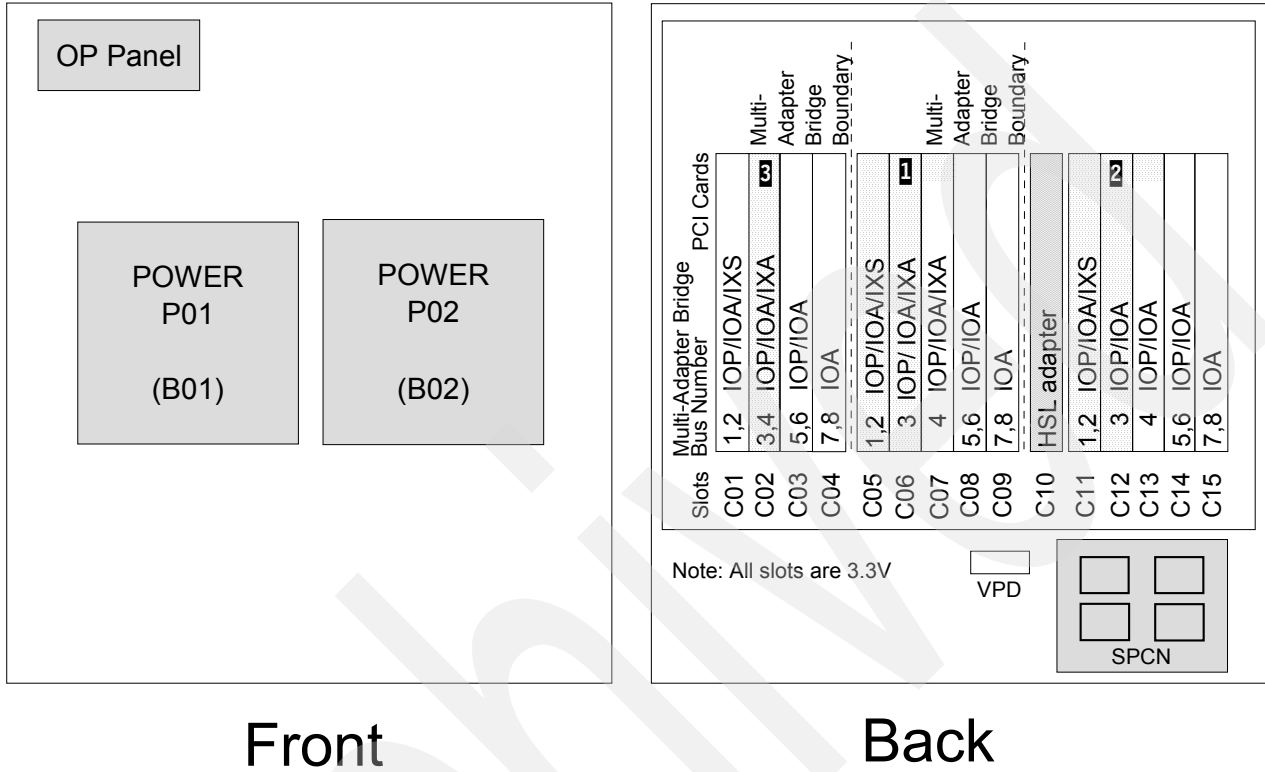

Legend

Base Feature

Required Feature

Unavailable if Integrated xSeries Server is installed

Slots

Note 1: If C05 has an Integrated xSeries Server, slot C06 is unavailable, and slot C07 is available only as a short slot. A #2792 does not reduce a third slot to a short slot.

Note 2: If C11 has an Integrated xSeries Server, slot C12 is unavailable, and slot C13 is available only as a short slot. A #2792 does not reduce a third slot to a short slot.

Note 3: IXS placement is not supported from plant. Only a #2792 is allowed in this position.

6.1.6 #5094 PCI Expansion Tower

The #5094 PCI-X Expansion Tower is supported by Models 520, 550, 570, 595, 800, 810, 820, 825, 830, 840, 870, and 890.

Note: The total number of disk bays is 45.

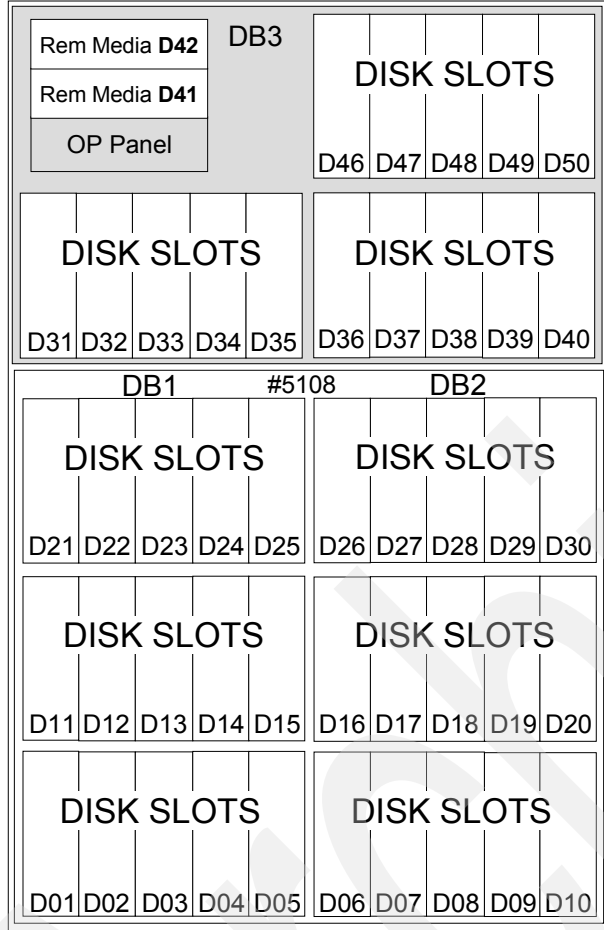

Front

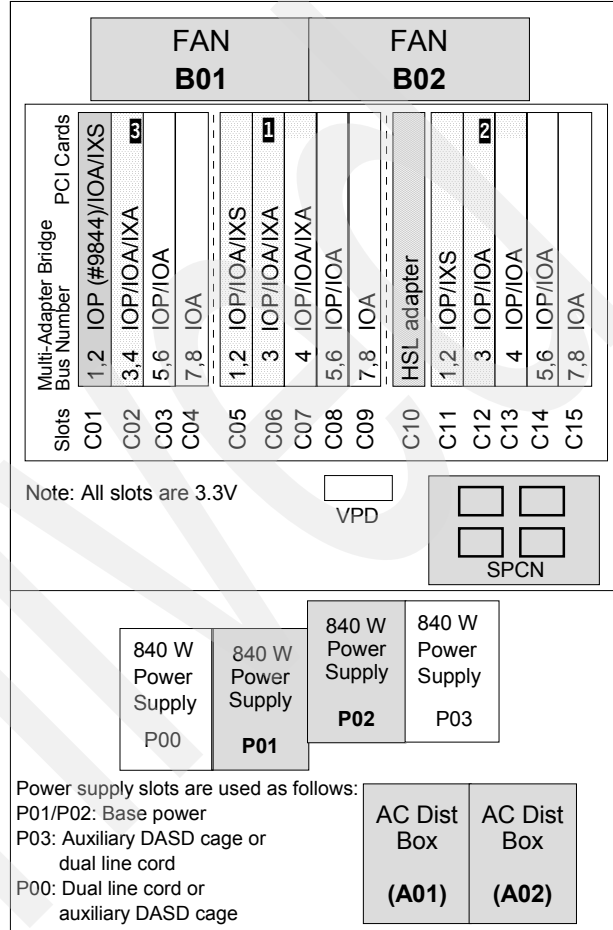

Back

Legend



Note 1: If C05 has an Integrated xSeries Server, slot C06 is unavailable, and slot C07 is available only as a short slot. A #2792 does not reduce a third slot to a short slot.

Note 2: If C11 has an Integrated xSeries Server, slot C12 is unavailable, and slot C13 is available only as a short slot. A #2792 does not reduce a third slot to a short slot.

Note 3: IXS placement is not supported from plant. Only a #2792 is allowed in this position.

6.1.7 #5095/#0595 PCI-X Expansion Tower

The #5095 PCI-X Expansion Tower and #0595 PCI-X Expansion Unit in Rack are supported by Models 270, 520, 570, 800, 810, 820, 825, 830, 840, 870, and 890.

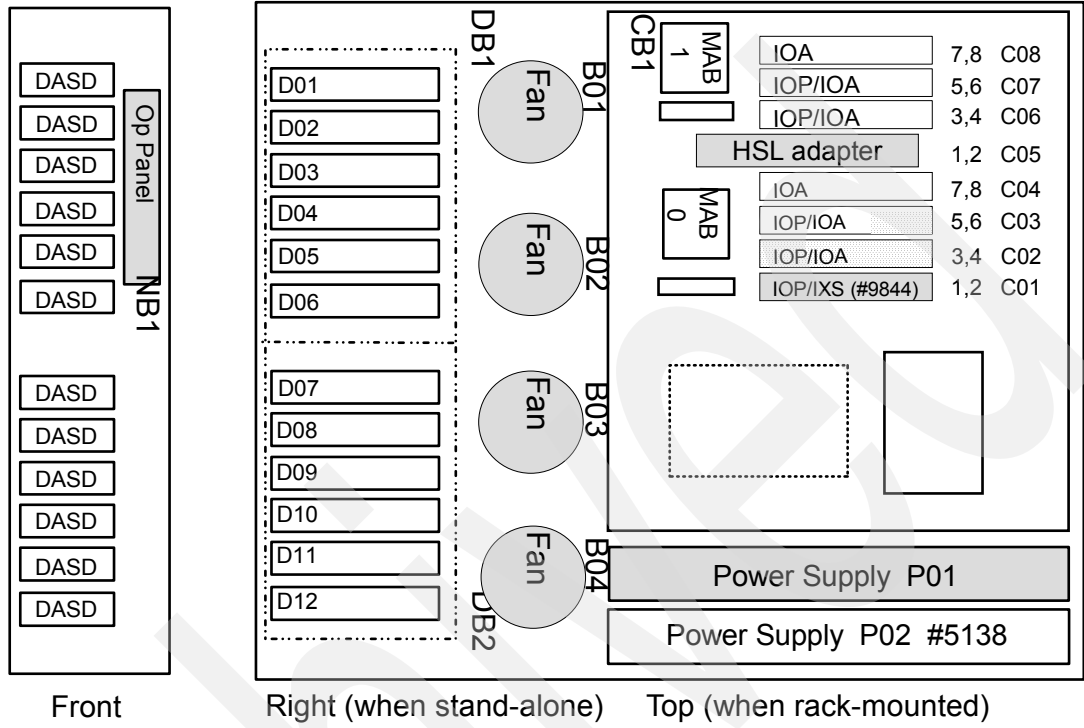

6.1.8 #5294 PCI-X Expansion Tower

The #5294 1.8m I/O Tower is supported by Models 520, 570, 820, 825, 830, 840, 870, and 890. The #5294 consists of two #5094 PCI-X Expansion Towers with side covers and casters removed.

Note: The total number of disk bays is 2 x 45.

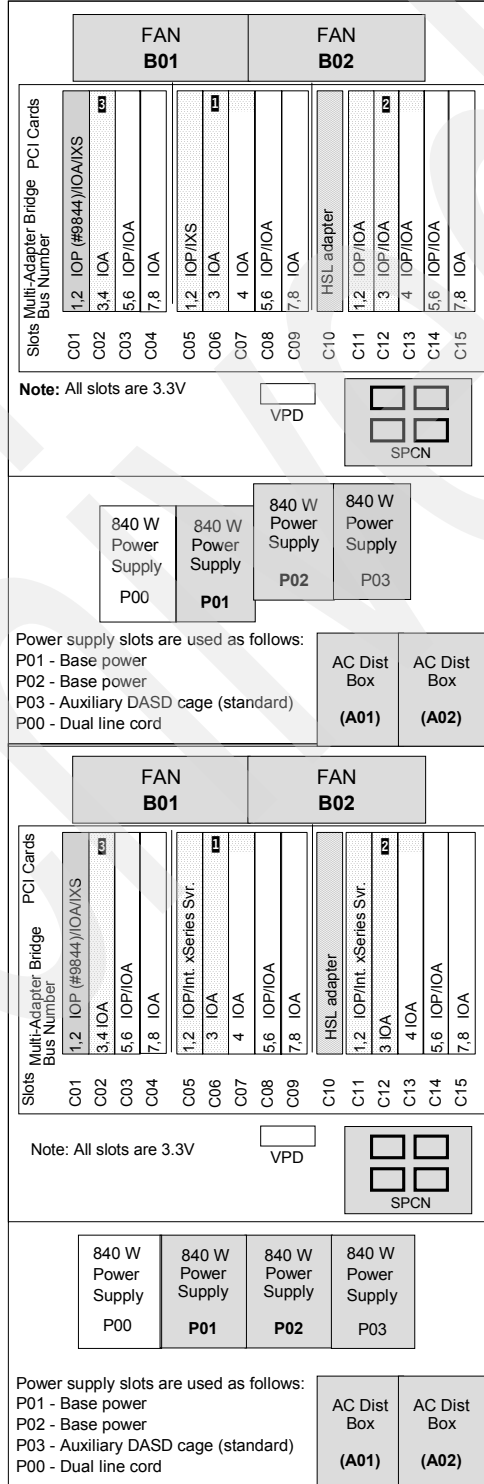
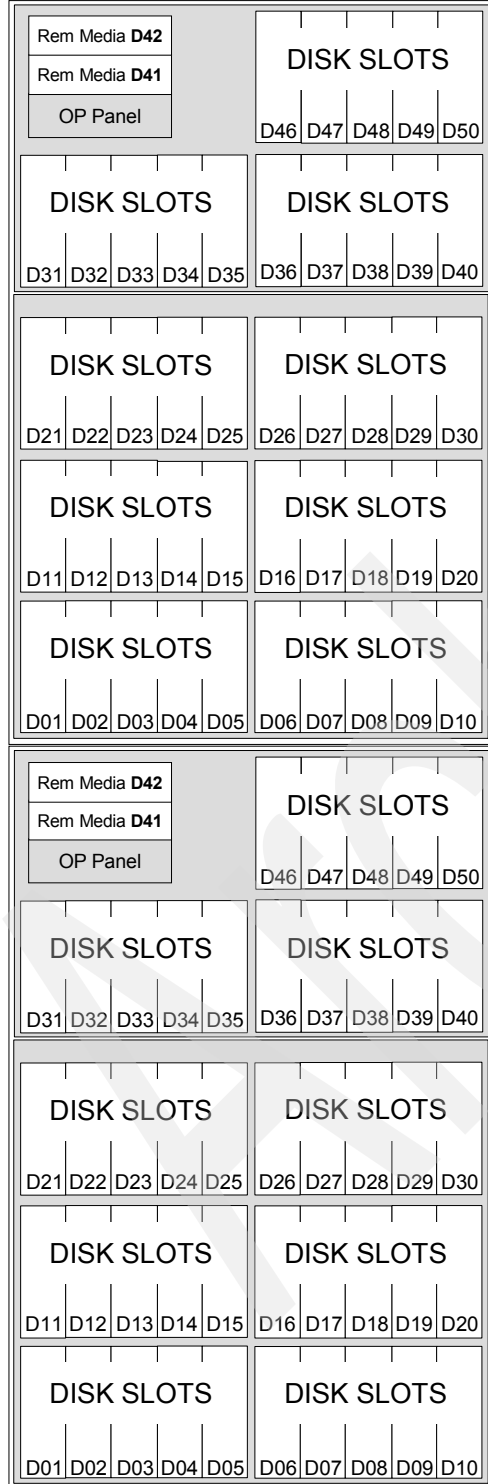

Legend

- Base Feature
- Required Feature
- Unavailable if Integrated Netfinity Server is installed

Note 1: If C05 has an Integrated xSeries Server, slot C06 is unavailable, and slot C07 is available only as a short slot. A #2792 does not reduce a third slot to a short slot.

Note 2: If C11 has an Integrated xSeries Server, slot C12 is unavailable, and slot C13 is available only as a short slot. A #2792 does not reduce a third slot to a short slot.

Note 3: IXS placement is not supported from plant. Only a #2792 is allowed in this position.

6.1.9 #5790 PCI Expansion Drawer

The #5790 PCI Expansion Drawer is supported on Models 520, 550 and 570. The #5790 mounts in #0551 iSeries Rack and #0553 iSeries 2.0 m Racks and uses four EIA units (half-width of the rack).

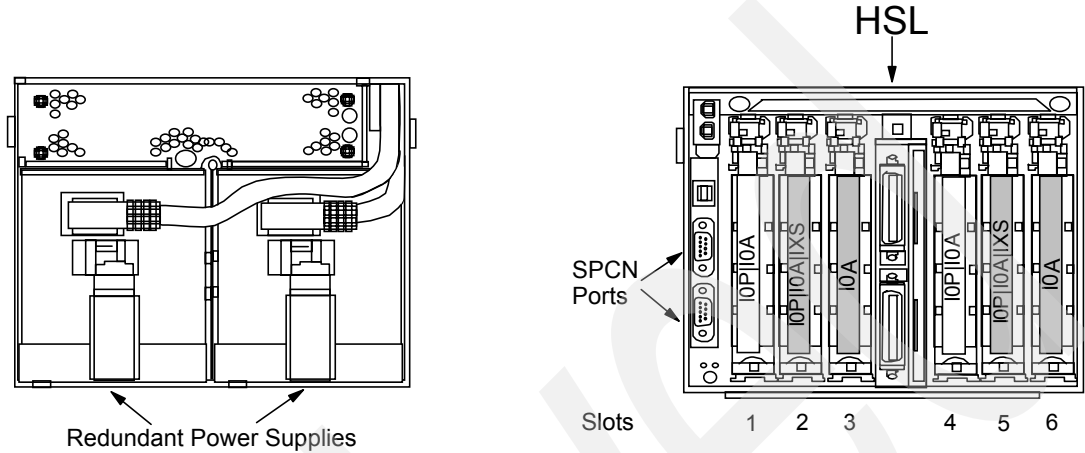

Note: A #4812 PCI Integrated xSeries Server consumes two slots.

6.1.10 #8093 Optional Base 1.8 m I/O Rack

The #8093 Optional 1.8 m I/O Rack is the 1.8m optional base I/O rack for the Model 870 and 890.

Note: The total number of disk bays is 2 x 45.

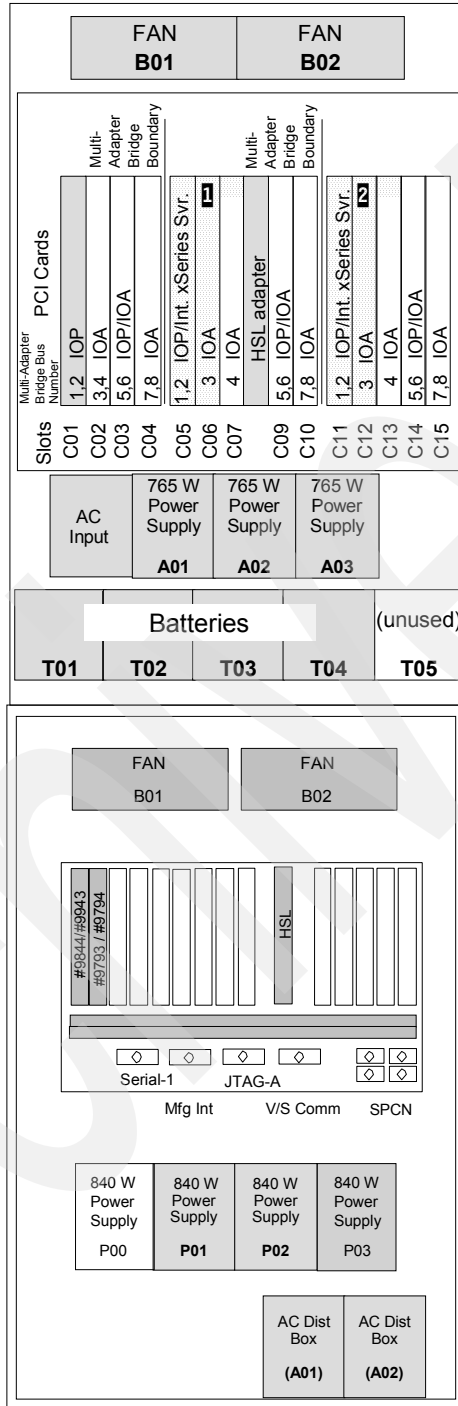
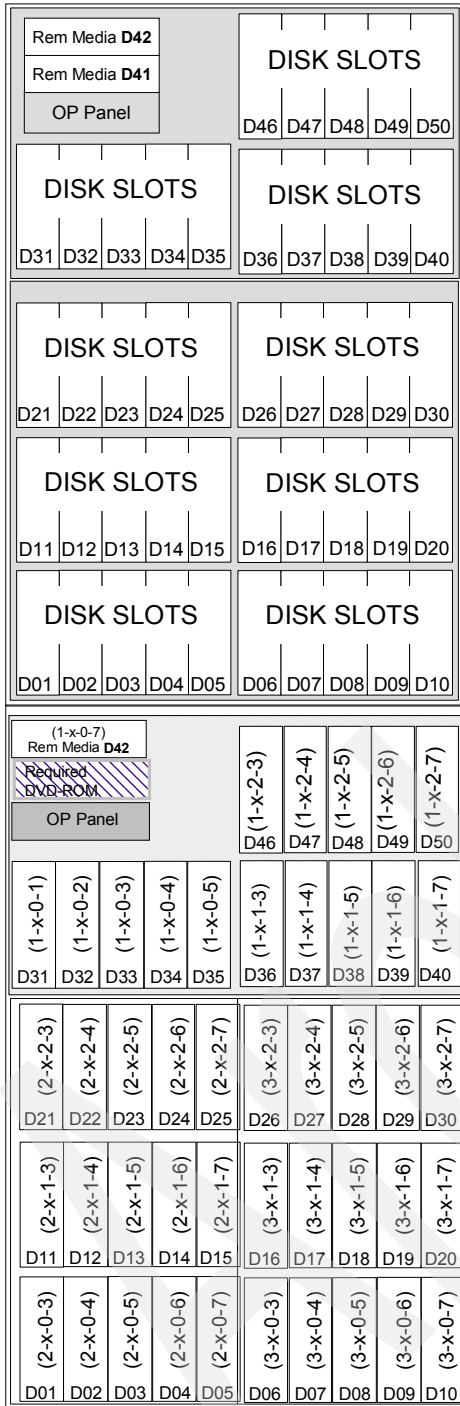

Legend

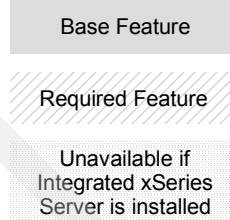

Note 1: If C05 has an Integrated xSeries Server, slot C06 is unavailable, and slot C07 is available only as a short slot.

Note 2: If C11 has an Integrated xSeries Server, slot C12 is unavailable, and slot C13 is available only as a short slot.

Note 3: The position of the cards may change depending on the console and other features selected.

See the #9094 PCI Card Enclosure for card placement details.

6.1.11 #8094 Optional 1.8 m I/O Rack

The #8094 Optional 1.8 m I/O Rack is the base I/O rack for the Model 870 and 890. It consists of a #5094 PCI-X Expansion Tower on top and a #9094 Base PCI I/O Enclosure on the bottom with side covers and casters removed.

Note: The total number of disk bays is 2 x 45.

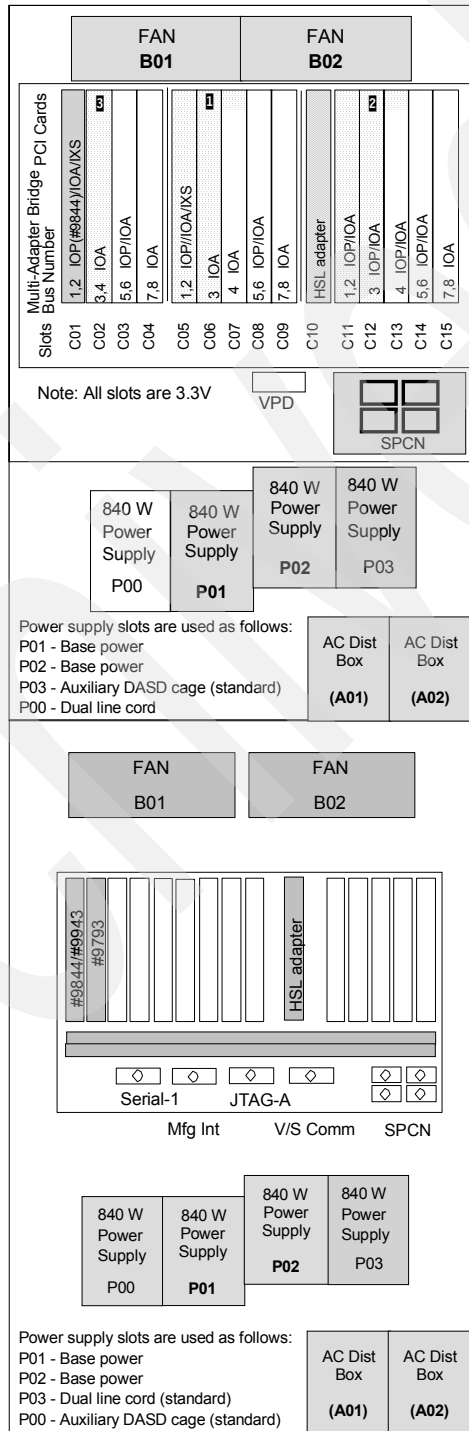
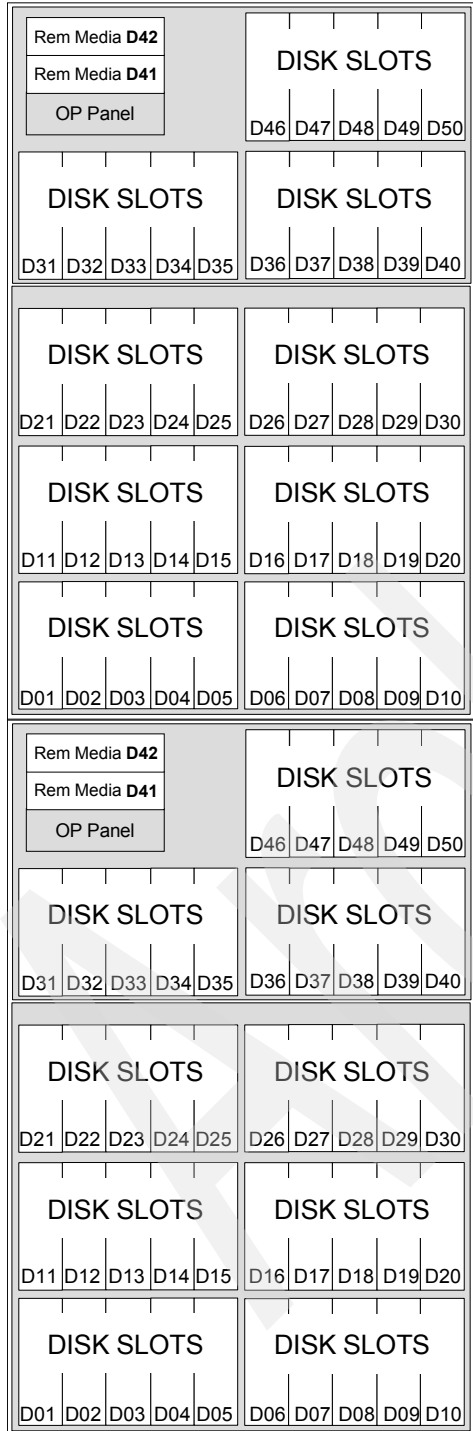

Legend

Base Feature

Required Feature

Unavailable if Integrated Netfinity Server is installed

Note 1: If C05 has an Integrated xSeries Server, slot C06 is unavailable, and slot C07 is available only as a short slot. A #2792 does not reduce a third slot to a short slot.

Note 2: If C11 has an Integrated xSeries Server, slot C12 is unavailable, and slot C13 is available only as a short slot. A #2792 does not reduce a third slot to a short slot.

Note 3: Integrated xSeries Server placement is not supported from the plant. Only a #2792 is allowed in this position.

See the #9094 PCI Card Enclosure for card placement details.

6.1.12 #9094 Base PCI I/O Enclosure

The #9094 Base PCI I/O Enclosure is the base I/O expansion unit for the Model 870 and 890.

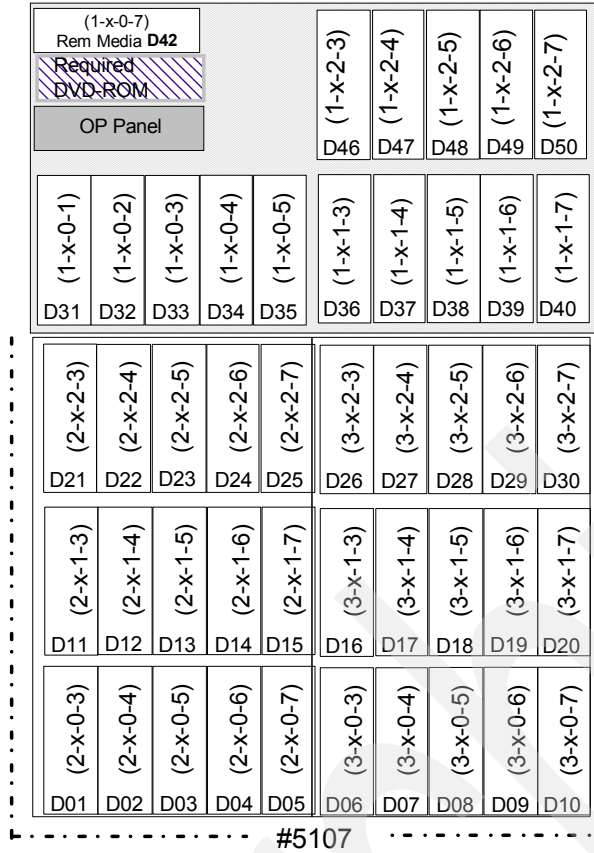

Front

Dual Line Cord

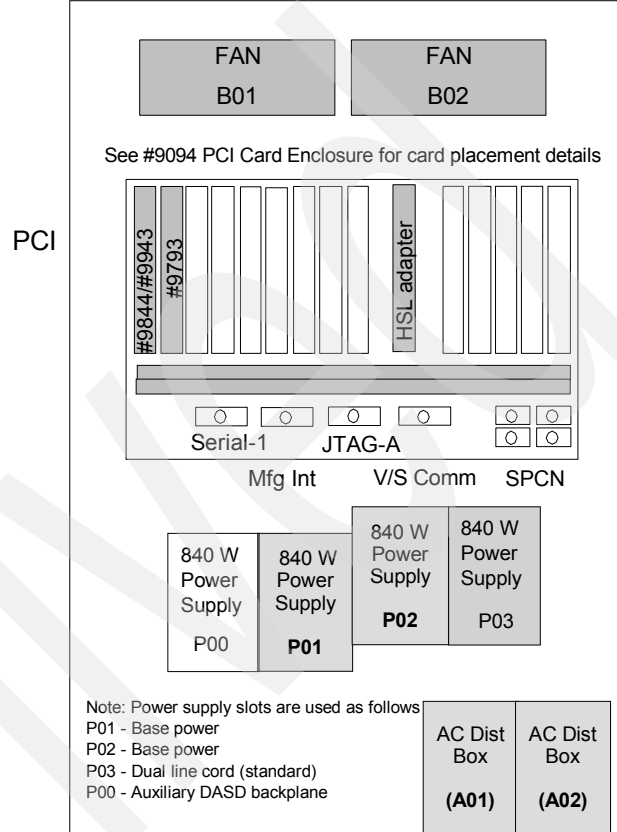

Back

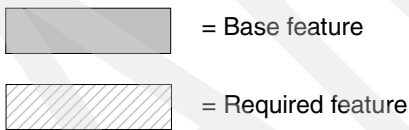

LEGEND

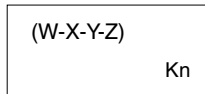

W = DS Card Address
 X = IOA number
 Y = SCSI bus number
 Z = AS/400 Drive Address
 Kn = Physical Address

Note: Hot plug and concurrent add of PCI cards, disk units, and removable media devices are supported.

6.1.13 #9094 PCI Card Enclosure

#9094 PCI Card Enclosure

Slots	Multi-Adapter Bridge PCI Bus Number	Cards
C01	1,2	#9844 / #9943
C02	3,4	#9793
C03	5,6	IOP/IOA
C04	7,8	IOA
Multi-Adapter Bridge Boundary		
C05	1,2	IOP/IXS
C06	3	IOA
C07	4	IOA
C08	5,6	IOP/IOA
C09	7,8	IOA
Multi-Adapter Bridge Boundary		
C10		HSL adapter
C11	1,2	IOP/IXS
C12	3	IOA
C13	4	IOA
C14	5,6	IOP/IOA
C15	7,8	IOA

Legend

Base Feature	Required Feature	Unavailable if Integrated xSeries Server is installed
--------------	------------------	---

Note 1: If C05 has an Integrated xSeries Server, slot C06 is unavailable, and slot C07 is available only as a short slot. A #2792 does not reduce a third slot to a short slot.

Note 2: If C11 has an Integrated xSeries Server, slot C12 is unavailable, and slot C13 is available only as a short slot. A #2792 does not reduce a third slot to a short slot.

Note 3: Slot C01 in the #9094 for a Model 870 has a #9844, and a #9844 or #9943 for a Model 890.

6.2 Required EIA units

The IBM marketing configurator does not manage rack space in System i racks. See Table 6-1 to determine the number of EIA units required for each Hardware Management console (HMC), System i system unit or expansion tower installed in a System i rack.

Table 6-1 EIA units

System i model or tower	#0551 iSeries Rack	#0553 iSeries 2.0 m Rack	#0554 iSeries 11U Rack	#0555 iSeries 25U Rack
Model 270 system unit	16 - includes two EIA for the #0133 and #0137			
Model 520 system unit	4	4		
Model 550 System Unit	4	4		
Model 570 processor enclosure	4	0/4 - 4 5/8 - 8 9/12 - 12 13/16 - 16		

System i model or tower	#0551 iSeries Rack	#0553 iSeries 2.0 m Rack	#0554 iSeries 11U Rack	#0555 iSeries 25U Rack
Model 595 processor enclosure	Not available in a #0551 iSeries Rack			
Model 800 system unit -	16 (includes 2 EIA for the #0133 and #0137)	16 (includes 2 EIA for the #0133 and #0137)		
Model 810 system unit	16 (includes 2 EIA for the #0133 and #0137)	16 (includes 2 EIA for the #0133 and #0137)		
Model 825 system unit	16 (includes 2 EIA for the #0134 and #0138)	16 (includes 2 EIA for the #0134 and #0138)		
#0595 PCI-X Expansion Unit in Rack	5	5		
#0578 PCI Expansion Unit in Rack	8			
#0588 PCI-X Expansion Unit in Rack	8	8		
#5074 PCI Expansion Tower	18			
#5790 PCI Expansion Drawer (half wide)		4		
#6586 Modem Tray for 19-Inch Rack	1U	1U	1U	1U
#7307 Dual I/O Unit Enclosure	4	4	4	4
#7311 Dual I/O Unit Enclosure	4	4	4	4
Model 7310-CR2 HMC rack mountable console		1		
#9079 Base I/O Tower	18			



Storage and media for IBM System i5, eServer i5, and iSeries models

This chapter describes miscellaneous facts for the storage options for IBM System i5, IBM eServer i5, and iSeries servers. Included are specifications for internal tape devices for ¼-inch cartridge, LTO and VXA compatibility, an explanation of the alternate installation device and IPL terminology, and cable information, including #2768 PCI Magnetic Media Controller device cabling rules.

7.1 External tape for System i5, eServer i5, and iSeries systems

External disk drives and subsystems offer an optional configuration for IBM System i5, eServer i5, and iSeries servers to extend disk storage capacity.

For descriptions of the external disk storage configurations supported on these servers, such as the TotalStorage Enterprise Storage Server, including the IBM TotalStorage DS6000™ and DS8000™ Families, refer to the IBM Total Storage related products to iSeries Web site at:

<http://www-03.ibm.com/servers/storage/support/eserver/iseries.html>

For information about other external tape devices, automated tape libraries, and optical devices, refer to:

<http://www-03.ibm.com/servers/storage/support/eserver/iseries-tape.html>

Some external tape devices are currently supported under an IOA only when that IOA is driven by an IOP on the System i server. Devices requiring an IOP/IOA include tape drives attached via a Fibre Channel controller, tape drives attached via an LVD SCSI controller (for example, the #5702/#5712 PCI-X Tape/DASD Controller and the #5736 PCI-X Disk/Tape Controller with IOP) and any tape drive attached via an HVD SCSI controller (for example, the #2749 PCI Ultra Magnetic Media Controller).

The following tape devices require an IOP-based controller:

- ▶ 3576
- ▶ 3580
- ▶ 3581
- ▶ 3582
- ▶ 3583
- ▶ 3584
- ▶ 3590
- ▶ 3592

The minimum operating system level for external tape storage depends on the operating system level required for the adapter. Some internal and external tape devices, optical disk, CD and DVD can be driven by IOP-less controllers. This capability requires i5/OS V5R3 with V5R3M5 LIC on the Model 520+ and i5/OS V5R4 on all other model 520, 550, 570 and 595 systems.

The devices supporting IOP-less controllers are as follows:

- ▶ #4684, #5753, 7207-330 and 7212-102 (#1107) and #9653 30GB QIC devices
- ▶ #4487, #4687 and 7212-102 (#1108) #5754 50GB QIC devices
- ▶ #1889, 7206-VX2 and 7212-102 (#1104) VXA-2 80Gb devices
- ▶ #6279, 7206-VXA3 and 7212-102 (#1114) VXA-320 160GB devices
- ▶ #5755 and 7212-102 (#1109) LTO-2 200 GB devices

Refer to *IBM TotalStorage Tape Selection and Differentiation Guide*, SG24-6946, to assist you in finding the best tape product solution for the designated backup environment. The latest edition of this IBM Redbook covers the 3494, 3580, 3581, 3582, 3583, 3584, 3590, 3592, and other tape products.

The maximum number of automated tape library drives supported depends on the adapter used to attach to the System i server.

Supported tape libraries include the 3580 IBM TotalStorage, 7329-308 SLR100 ¼-inch Tape Autoloader, IBM TotalStorage 3494 Enterprise Tape Library, 3575 Magstar® MP Tape

Library Dataserver, IBM TotalStorage 3582 Ultrium Tape Library, IBM 3583 Ultrium Scalable Tape Library and the 3584 Ultra Scalable Tape Library Model L22.

External optical storage for IBM System i5, eServer i5, and iSeries systems are the 3995 Optical Library Dataserver, 3996 Optical Library, 7210-020 External CD-ROM, 7210-025 External DVD-RAM and 7210-030 External DVD-RAM.

Note: The Update Device Microcode API (QTAUPDDV) allows tape device microcode to be updated using an image copied from the Web. This function is supported with i5/OS Version 5 systems and OS/400.

7.1.1 Alternate IPL or alternate installation device

The term *alternate IPL* or *ALT-IPL* is used in this book to describe both alternate IPL devices and alternate installation devices. It is important to understand the differences. An alternate IPL device must be attached to the first system bus (bus one), and an alternate installation device can be attached to any bus except bus one.

Alternate installation device support allows you to perform installation and recovery procedures using a combination of devices. Prior to V4R1, these types of activities can only be performed using devices attached to the first system bus. The first system bus connects to the service processor IOP. Typically, this is where the optical device or tape devices used for installations are attached. From OS/400 V4R1 onward, you can use a combination of devices that are attached on the first system bus and on additional buses. The alternate installation device is not attached to the first system bus.

If you use this function, the system uses existing support (a device on the first system bus) to install or recover enough of the Licensed Internal Code (LIC) required to perform an IPL with IPL-type D. Then, using the new alternate installation device support, the system continues the operation using media in the alternate installation device. This new function supports installation and recovery from tape media, such as SAVSYS tapes or distribution tapes that you created, which contains LIC and might contain the operating system, licensed programs, and data.

Note: The #2765 PCI Fibre Channel Tape Controller and #5704 PCI-X Fibre Channel Tape Controller do not support the alternate IPL device function. A D-mode IPL is required using CD-ROM, DVD-ROM, or another ALT-IPL tape device. Then select a #2765 or #5704 to complete the installation or recovery process.

See *Backup and Recovery*, SC41-5304, for more information.

7.2 SAN components for IBM System i5, eServer i5 and iSeries systems

For information about storage area networks (SANs) supported by iSeries servers, refer to:

<http://www-03.ibm.com/servers/storage/support/eserver/iseries-san.html>
<http://www-1.ibm.com/servers/storage/san/index.html>
<http://www-1.ibm.com/servers/storage/support/san/index.html>
<http://knowledge.storage.ibm.com/HBA/HBASearchTool>

7.3 QIC tape specifications and compatibility for IBM System i5, eServer i5, and iSeries systems

The following table provides device specifications, performance, and compatibility details for internal QIC tape formats.

IBM tape device					QIC-2 GB	QIC-2 GB DC	4/8GB SLR5 QIC-4 GB DC	MLR1 QIC 5010 DC	MLR1 QIC 5010 DC	MLR3	SLR 60	SLR 100
Drive storage capability					2.5 GB ⁴	2.5 GB ⁴	4 GB	13 GB ⁴	16 GB	25 GB	30 GB	50 GB
Compaction algorithm						LZ1	LZ1	LZ1	LZ1	LZ1	LZ1	LZ1
Minimum OS/400 level					V4R1	V4R1	V4R1	V3R7	V4R1	V4R1	V4R5	V5R1
Format	Capacity	Native data transfer rate	Media	Media part number	#6380 #6480	#6381 #6481	#4482 #4582 #6382 #6482 7207-122	#6385 ⁷ #6485 ⁷	#4483 #4583 #6383 #6483	#4486 #4586 #6386 #6486	#4584 #4684 #5753 ⁶ #6384 #6484 #9284 #9653 ⁶ 7207-330	#4487 #4587 #5754 ⁶ #8287 #8754 ⁶ #4687 7329-380
MLR3 ¹	25 GB ⁸	2 MBps	MLR3-25GB	59H4128	--	--	--	--	--	R/W	R/W	R/W
QIC5010 ¹	16 GB	1.5 MBps	MLR1-16GB	59H4175	--	--	--	R/W	R/W	R/W	R/W	R
	13 GB	1.5 MBps	DC5010	16G8574	--	--	--	R/W	R/W	R/W	R/W	R
	2 GB	1.5 MBps	MLR1-2 GB	35L0589	--	--	--	R/W	R/W	R/W	R/W	R
QIC4DC ²	8 GB	760 KB/s	SLR5-4 GB	59H3660	--	--	R/W	--	R	R	R	R
QIC4GB	4 GB	380 KB/s	SLR5-4 GB	59H3660	--	--	R/W	--	R	R	R	R
QIC2DC ²	5 GB	600 KB/s	DC9250	16G8436	--	R/W	R/W	--	R	R	R	
QIC2GB	2.5 GB	300 KB/s	DC9250	16G8436	R/W	R/W	R/W	R/W	R	R	R	
QIC1000	1.2 GB	300 KB/s	DC9120	21F8730	R/W	R/W	R/W	R/W	--	--		
QIC525	525 MB	200 KB/s	DC6525	21F8597	R/W	R/W	R/W	R/W ⁵	--	--		
QIC525	320 MB	200 KB/s	DC6320	21F8583	R/W	R/W	R/W	R/W	--	--		
QIC120	120 MB	120 KB/s	DC6150	21F8578	R/W	R/W	R/W	R/W ⁵	--	--		
QIC24 ³	60 MB		DC6150		R	R	--	--	--	--		
SLR100	50 GB	5 MBps	SLR100-50	35L0968	--	--	--	--	--	--	--	R/W
	5 GB	5 MBps	SLR100-5G	35L0961	--	--	--	--	--	--	R/W	R/W
SLR60	30 GB	4 MBps	SLR60-30G	19P4209	--	--	--	--	--	--	R/W	R/W
	37.5 GB	4 MBps	SLR60-37.5 GB	24R0146	--	--	--	--	--	--	R/W	R/W

Notes:

- Indicates that the capacity can double typically when the compression option is selected.
- QIC-2DC and QIC-4DC are compression formats. Cartridge capacity is data dependent. Capacities shown are typical.
- QIC24 format is written by S/36.
- Available as a migration feature only during an upgrade.
- Use of DC6150 and DC6525 media can shorten the life of the tape device and require more frequent maintenance.
- Requires i5/OS V5R3
- The internal 13 GB tape drives with feature code #6385 or #6485 also supports the 16 MB IBM MLR1 tape media.
- Minimum operating system to support the 25GB capacity cartridge drive: V4R1.

7.4 VXA and LTO tape specifications and compatibility for IBM System i5, eServer i5, and iSeries systems

The following table provides device specifications, performance, and compatibility details for internal LTO and VXA tape formats.

IBM tape device					VXA-2	VXA 320	LTO-2 Tape Unit
Drive storage capability					80 GB	160 GB	400GB
Compaction algorithm					ALDC	ALDC	SLDC
Minimum operating system level					OS/400 V5R1	i5/OS V5R3	i5/OS V5R3
Format	Native Media Capacity	Native data transfer rate	Media	Media part number	#1889 ⁶ #4585 #4685 #9285 #9689 ⁶	#6279	#5755
VXA1 ^{1,6}	59 GB	6 MBps	V17-59GB	19P4877	R/W	--	
	20 GB	6 MBps	V6-20GB	19P4878	R/W	--	
	20 GB	6 MBps	V6-test	19P4879	R/W	--	
VXA2 ^{1,3}	80 GB	6 MBps	V23-80GB	19P4876	R/W	R/W	
	59 GB	6 MBps	V17-59GB	19P4877	R/W	--	
	20 GB	6 MBps	V6-20GB	19P4878	R/W	--	
	20 GB	6 MBps	V6-test	19P4879	R/W	--	
	80 GB	6 MBps	X23-80GB	24R2137	R/W	R/W	
	40 GB	6 MBps	X10-40GB	24R2136	R/W	R/W	
	20 GB	6 MBps	X6-20GB	24R2134	R/W	R/W	
	20 GB	6 MBps	X6-test	24R2135	R/W	R/W	
VXA3 ^{1,2,4,5}	80 GB	12 MBps	V23-80GB	19P4876	--	R/W	
	80 GB	12 MBps	X23-80GB	24R2137	--	R/W	
	40 GB	12 MBps	X10-40GB	24R2136	--	R/W	
	20 GB	12 MBps	X6-20GB	24R2134	--	R/W	
	20 GB	12 MBps	X6-test	24R2135	--	R/W	
LTO 1	200 GB	24 MBps	LTO Ultrium 1	09L9120			R/W
LTO 2 ¹	400 GB	24 MBps	LTO Ultrium 2	08L9870			R/W
Notes: 1. Indicates that the capacity can double typically when the compression option is selected. 2. The VXA3 format doubles the native capacity of the media. 3. The VXA-2 drive can use VXA1 and VXA2 formats. 4. The VXA-320 drive can use VXA2 and VXA3 formats. The VXA-320 drive can read VXA-1 formats. 5. The VXA-320 drive auto-ejects all V-type media except V23. 6. The VXA1 format is not supported on V23 and X-type media.							

7.5 External SCSI, Fibre Channel tape, and optical cable part numbers for IBM System i5, eServer i5, and iSeries systems

The following tables provide the cable part number for SCSI and Fibre Channel attached devices. Part numbers might not be available in all countries or regions.

Note: The length in feet is rounded to the nearest whole number.

SCSI cables for #2729 PCI Magnetic Media Controller, #2749 PCI Ultra Magnetic Media Controller, #6534 Magnetic Media Controller, and #6501 Tape/Disk Device Controller			
Tape drive	Length	Part number	Feature code
3490 C10, C11, C22 with #5040 - SCSI attach #6501 attach only	4.5m (15 ft) 12.0m (39 ft) 18.0m (59 ft)	61G8328 61G8329 61G8330	6045 6120 6180
3490 E01, E11 3590 B11, B1A, E11, E1A, H11, H1A	2.8m (9 ft) (HD68 to HD68) 4.5m (15 ft) (HD68 to HD68) 12.0m (39 ft)(HD68 to HD68) 18.0m (59 ft)(HD68 to HD68) 25.0m (82 ft)(HD68 to HD68)	05H4647 05H4648 05H4649 05H4650 05H4651	5128 5145 5112 5118 5125
3490 F00, F01, F11 3570 BXX and CXX 7208 - 342 9427 - 210, 211	0.5m (2 ft) (HD68 to HD68) 4.5m (15 ft) (HD68 to HD68) 12.0m (39 ft)(HD68 to HD68) 18.0m (59 ft)(HD68 to HD68) 25.0m (82 ft)(HD68 to HD68)	49G6456 49G6457 49G6458 49G6459 08L6201	5205 5245 5212 5218 5225 (3570 Cxx)
3580-H11, H13, H23 3581-H17 3581-L28 (with #3104 HVD converter) 3582-L23 3583 HVD drives 3584 HVD drives #1455 if shipped prior to 31 August 2001, and HVD drives #1465 *	0.41m (1.5 ft)(HD68 to HD68) 0.72m (2.4 ft) (HD68 to HD68) 2.5m (8 ft)(HD68 to HD68) 5.0m (16 ft) (HD68 to HD68) 10.0m (33 ft)(HD68 to HD68) 18.0m (59 ft) (HD68 to HD68) 25.0m (82 ft) (HD68 to HD68) VHDCI to HD68 interposer Interposer for #6501	19P0872 19P0873 35L1307 19P0052 19P0053 19P0097 19P0054 19P0482 05H3834	5302 (9702 - 3580, 3581) 5305 (9705 - 3583) 5310 5318 5325 5099 2895
* 3584 HVD drives #1455 shipped on or after 31 August 2001 and HVD drives #1475 have VHDCI connectors, so these drives can use the VHDCI to HD68 cables shown for adapters #5702 and #5705, or they require the VHDCI to HD68 interposer.			

SCSI cables for #2729 PCI Magnetic Media Controller, #2749 PCI Ultra Magnetic Media Controller, and #6534 Magnetic Media Controller			
Tape drive	Length	Part number	Feature code
3995 - C4x	12.0m (39 ft)	05H5543	7401/9401
	12.0m (39 ft) (for #2621 attach only)	05H5439	7400/9400
7208 - 012	1.5m (5 ft)	52G0174	2871
	4.0m (13 ft)	59H3462	2903
	12.0 (39 ft)	59H3463	2904
7208 - 222/ 232/234 9348 - 001/002	1.0m (3 ft)	06H6037	2875
	4.0m (13 ft)	59H3460	2901
	12.0m (39 ft)	59H3461	2902
7208 - 342	4.5m (15 ft)	49G6457	5245/9245
	12.0m (39 ft)	49G6458	5212/9212
	18.0m (59 ft)	49G6459	5218/9218

SCSI cables for #2718 PCI Magnetic Media Controller and #2768 PCI Magnetic Media Controller			
Tape drive	Length	Part number	Feature code
7206-VX2	1.5m (5 ft) (HD68 to HD68)	19P4506	5300/9750
	2.5m (8 ft) (HD68 to HD68)	35L1307	5302/9752
7207 - 122 7207 - 330 7208 - 345	1.5m (5 ft) (HD68 to HD68)	19P4506	5300/9750
	2.5m (8 ft) (HD68 to HD68)	35L1307	5302/9752
7210 - 020	1.0m (3 ft) (HD68 to LD50)	06H6037	2872/9148
7210 - 025 ¹ 7210 - 030 ^{2, 3} 7212 - 102 ^{2, 3}	1.5m (5 ft) (HD68 to HD68)	19P4506	5300/9750
	2.5m (8 ft) (HD68 to HD68)	35L1307	5302/9752
7329 - 308	2.4m (8ft) (HD68 to HD68)	67G1260	5224/9224
Notes:			
1. Maximum cable length for the 7210-025 is 2.5 m.			
2. The Model 7210-030 and 7212-102 do not connect via the #2718.			
3. The maximum cable length attached to #2768 is 2.5 m.			

SCSI cables for #5715/#5705 PCI-X Tape/DASD Controller (one port), #5702 PCI-X Ultra Tape Controller/#5712 PCI-X Tape/DASD Controller (two ports, VHDCI interface), #0647/#5775 PCI-X Disk/Tape Controller without IOP and #5736 PCI-X Disk/Tape Controller with IOP/#5766 PCI-X Tape Controller			
Tape drive	Length	Part number	Feature code
3580-L23 3582 Drives #8103, #8203 3583 Drives #8103	2.5m (8 ft) (VHDCI to HD68) 4.5m (14.5 ft) (VHDCI to HD68) 10.0m (33 ft) (VHDCI to HD68) 20.0m (66 ft) (VHDCI to HD68) 25.0m (82 ft) (VHDCI to HD68) Interposer VHDCI to HD68	19P0279 19P0050 19P0048 19P0049 35L1977 19P0872	5602 (9703 - 3580) 5604 (9704 - 3583) 5610 5620 5625 5099
3581-L28	2.5m (8 ft) (VHDCI to HD68) 4.5m (14.5 ft) (VHDCI to HD68) 10.0m (33 ft) (VHDCI to HD68) 25.0m (82 ft) (VHDCI to HD68)	CRU ¹	5602 (9703) 5604 5610 5625
3584 Drives #1474	4.5m (14.5 ft) (VHDCI to VHDCI) 10.0m (33 ft) (VHDCI to VHDCI) 20.0m (66 ft) (VHDCI to VHDCI) 25.0m (82 ft) (VHDCI to VHDCI)	19P2499 09L0881 19P1904 19P2500	5704 5710 5702 5725
3996-032, 080, 174	4.5m (14.5 ft) (VHDCI to HD68) 10.0m (33 ft) (VHDCI to HD68)	19P0050 19P0048	5604 5610
7206-VX2 7208-345	1.5m (5 ft) (VHDCI to HD68) 2.5m (8 ft) (VHDCI to HD68) 4.5m (14.5 ft) (VHDCI to HD68) ² 10.0m (33 ft) (VHDCI to HD68) ²	19P4508 19P0279 19P0050 19P0048	5601/9761 5602/9762 5604/9764 5610/9760
7207 - 122	1.5m (5 ft) (VHDCI to HD68) 2.5m (8 ft) (VHDCI to HD68)	19P4508 19P0279	5601/9761 5602/9762
7207 - 330	1.5m (4.5 ft) (VHDCI to HD68) 2.5m (8 ft) (VHDCI to HD68) 4.5m (14.5 ft) (VHDCI to HD68) ² 10.0m (33 ft) (VHDCI to HD68) ²	19P4508 19P0279 19P0050 19P0048	5601/9761 5602/9762 5604/9764 5610/9760
7210 - 020	1.0m (3 ft) (HD68 to LD50) also require interposer VHDCI to HD68	06H6037 19P0482	2872/9148 5099
7210 - 025	0.5m (2 ft) (VHDCI to HD68) 1.5m (5 ft) (VHDCI to HD68) 2.5m (8 ft) (VHDCI to HD68)	19P4507 19P4508 19P0279	5600/9765 5601/9761 5602/9762
7210 - 030 ²	0.5m (2 ft) (VHDCI to HD68) 1.5m (4.5 ft) (VHDCI to HD68) 2.5m (8 ft) (VHDCI to HD68) 4.5m (14.5 ft) (VHDCI to HD68) ²	19P4507 19P4508 19P0279 19P0050	5600/9765 5601/9761 5602/9762 5604/9764
7212 - 102 ²	0.5m (2 ft) (VHDCI to HD68) 1.5m (4.5 ft) (VHDCI to HD68) 2.5m (8 ft) (VHDCI to HD68) 4.5m (14.5 ft) (VHDCI to HD68) ² 10.0m (33 ft) (VHDCI to HD68) ²	19P4507 19P4508 19P0279 19P0050 19P0048	5600/9765 5601/9761 5602/9762 5604/9764 5610/9760
Notes:			
1. Customer Replaceable Unit. Use feature code to order.			
2. 4.5m and 10.0m cable can be used only if the 7206-VX2, 7207-330, 7212-102 or 7208-345 is the only device on the bus.			

Fibre Channel cables for #5704 PCI-X Fibre Channel Tape Controller (LC) and #2765 PCI Fibre Channel Tape Controller (LC)

Tape device	Length	Part number	Feature code
3581-F28	5m (16 ft) Fibre Channel (LC-LC) 25m (82 ft) Fibre Channel (LC-LC) 61m (200 ft) Fibre Channel (LC-LC) 7m (23 ft) Fibre Channel (LC-SC) 22m (72 ft) Fibre Channel (LC-SC) 61m (200 ft) Fibre Channel (LC-SC)	CRU*	#6005 #6025 #6061 #5907 #5922 #5961
3582 Drives #8105, #8205	5m (16 ft) Fibre Channel (LC-LC) 13m (43 ft) Fibre Channel (LC-LC) 25m (82 ft) Fibre Channel (LC-LC) 61m (200 ft) Fibre Channel (LC-LC) 7m (23 ft) Fibre Channel (LC-SC) 13m (43 ft) Fibre Channel (LC-SC) 22m (72 ft) Fibre Channel (LC-SC) 61m (200 ft) Fibre Channel (LC-SC)	19K1252 11P3880 19K1253 11P3884 11P3895 11P3896 11P3897 11P3900	#6005 #6013 #6025 #6061 #5907 #5913 #5922 #5961
3583 Drives #8105 or SDGM	5m (16 ft) Fibre Channel (LC-LC) 13m (43 ft) Fibre Channel (LC-LC) 25m (82 ft) Fibre Channel (LC-LC) 61m (200 ft) Fibre Channel (LC-LC) 7m (23 ft) Fibre Channel (LC-SC) 13m (43 ft) Fibre Channel (LC-SC) 22m (72 ft) Fibre Channel (LC-SC) 61m (200 ft) Fibre Channel (LC-SC) 5m (16 ft) Fibre Channel (SC-SC) 13m (43 ft) Fibre Channel (SC-SC) 25m (82 ft) Fibre Channel (SC-SC) 61m (200 ft) Fibre Channel (SC-SC)	19K1252 11P3880 19K1253 11P3884 11P3895 11P3896 11P3897 11P3900 03K9202 54G3386 03K9204 54G3390	#6005 #6013 #6025 #6061 #5907 #5913 #5922 #5961 #5805 #5813 #5825 #5861
3584 Fibre Channel Drives #1456, #1466, #1479	5m (16 ft) Fibre Channel (LC-LC) 13m (43 ft) Fibre Channel (LC-LC) 25m (82 ft) Fibre Channel (LC-LC) 61m (200 ft) Fibre Channel (LC-LC) 7m (23 ft) Fibre Channel (LC-SC) 13m (43 ft) Fibre Channel (LC-SC) 22m (72 ft) Fibre Channel (LC-SC) 61m (200 ft) Fibre Channel (LC-SC) 5m (16 ft) Fibre Channel (SC-SC) 13m (43 ft) Fibre Channel (SC-SC) 25m (82 ft) Fibre Channel (SC-SC) 61m (200 ft) Fibre Channel (SC-SC)	19K1252 11P3880 19K1253 11P3884 11P3895 11P3896 11P3897 11P3900 03K9202 54G3386 03K9204 54G3390	#6005 #6013 #6025 #6061 #5907 #5913 #5922 #5961 #5805 #5813 #5825 #5861
3590-E1A, E11, H1A, H11	7m (23 ft) Fibre Channel (LC-SC) 13m (43 ft) Fibre Channel (LC-SC) 22m (72 ft) Fibre Channel (LC-SC) 61m (200 ft) Fibre Channel (LC-SC) 5m (16 ft) Fibre Channel (SC-SC) 13m (43 ft) Fibre Channel (SC-SC) 25m (82 ft) Fibre Channel (SC-SC) 61m (200 ft) Fibre Channel (SC-SC)	11P3895 11P3896 11P3897 11P3900 03K9201 54G3386 03K9203 54G3390	#5907 #5913 #5922 #5961 #5805 #5813 #5825 #5861
3592-J1A	5m (16 ft) Fibre Channel (LC-LC) 13m (43 ft) Fibre Channel (LC-LC) 25m (82 ft) Fibre Channel (LC-LC) 61m (200 ft) Fibre Channel (LC-LC) 7m (23 ft) Fibre Channel (LC-SC) 13m (43 ft) Fibre Channel (LC-SC) 22m (72 ft) Fibre Channel (LC-SC) 61m (200 ft) Fibre Channel (LC-SC)	19K1252 11P3880 19K1253 11P3884 11P3895 11P3896 11P3897 11P3900	#6005 #6013 #6025 #6061 #5907 #5913 #5922 #5961

* Customer Replaceable Unit, use feature code to order

External Storage

7.6 Device cabling rules for #5702, #5705, #5712, #5715, #2718, and #2768 PCI Magnetic Media Controller

The #2718, #2768, #5702, #5705, #5712, and #5715 provide Ultra SCSI attachment capability for an external tape, an external CD-ROM device, or an external DVD-RAM device that have a Single Ended SCSI interface. The #5702 PCI-X Ultra Tape Controller and #5712 PCI-X Tape/DASD Controller have two SCSI ports, each port providing the same attachment capability of the #2718, #2768, #5705 and #5715. This doubles the capability.

The supported devices are:

- ▶ 7206-VX2 80 GB External VXA-2 Tape Drive
- ▶ 7207-122 QIC-SLR Tape Bridge Box (4 GB External ¼-inch Cartridge Tape Drive)
- ▶ 7207-330 30GB External SLR60 Tape Drive
- ▶ 7208-345 60 GB External 8mm Tape Drive
- ▶ 7210-020 External CD-ROM
- ▶ 7210-025 External DVD-RAM
- ▶ 7210-030 External DVD-RAM
- ▶ 7212-102 IBM TotalStorage Storage Device Enclosure
- ▶ 7329-308 SLR100 ¼-inch Tape Autoloader

The following combination of devices are supported:

- ▶ One 7206-VX2
- ▶ One 7207-122
- ▶ One 7207-330
- ▶ One 7208-345
- ▶ One 7210-020
- ▶ One 7210-025
- ▶ One 7210-030
- ▶ One 7212-102
- ▶ One 7329-308
- ▶ Two 7210-025s (the two devices are daisy-chained)
- ▶ Two 7210-030s (the two devices are daisy-chained)
- ▶ One 7210-025 and one 7210-020 (the two devices are daisy-chained with the 7210-025 physically connected first; no #0120 attachment specify code is required for the 7210-020)
- ▶ One 7210-030 and one 7207-122 (the two devices are daisy-chained with the 7207-122 physically connected first)
- ▶ One 7210-030 and one 7208-345 (the two devices are daisy-chained with the 7208-345 physically connected first)
- ▶ One 7210-030 and one 7210-025 (the two devices are daisy-chained with the 7210-030 physically connected first)
- ▶ One 7207-122 and one 7210-020 (the two devices are daisy-chained with the 7207-122 physically connected first; no #0120 attachment specify code is required for the 7210-020)
- ▶ One 7207-122 and one 7210-025 (the two devices are daisy-chained with the 7207-122 physically connected first)
- ▶ One 7208-345 and one 7210-020 (the two devices are daisy-chained with the 7208-345 physically connected first; no #0120 attachment specify code is required for the 7210-020)
- ▶ One 7208-345 and one 7210-025 (the two devices are daisy-chained with the 7208-345 physically connected first)

The #0120 7210-020 Attachment Specify is required for each 7210-020 External CD-ROM drive to be connected directly (not daisy-chained) to the system through a #2718, #2768, #5702, or #5705.

Note: If the 7210-020 is to be daisy-chained with another external device, this specify code must not be present.

The #0162 Extended Single Ended Attach Specify is required when these devices are directly attached (not second on a daisy-chained string) to an iSeries server via a #2718 PCI Magnetic Media Controller, #2768 PCI Magnetic Media Controller, #5702 PCI-X Ultra Tape Controller/#5712 PCI-X Tape/DASD Controller, or #5705/#5715 PCI-X Tape/DASD Controller.

- ▶ 7210-025 External DVD-RAM
- ▶ 7210-030 External DVD-RAM
- ▶ 7329-308 SLR100 ¼-inch Tape Autoloader

Note: If any of these devices are daisy-chained off another device, the #0162 specify must not be present.

Archived

Customer Card Identification Numbers cross reference

The following list contains the Customer Card Identification Number (CCIN), feature code, for many System i5 family features. It assists IBM Clients and personnel in configuring Miscellaneous Equipment Specifications (MES) and upgrades. It provides a cross reference for the CCIN number reported by the Hardware Resources Listing with a feature code used for ordering.

The CCIN number is used when working from a Hardware Resource Listing. The Hardware Resource Listing is also known as the Rack Configuration Listing. The entries selected are those which are most useful when interpreting Hardware Resource Listings.

See Chapter 9, "Feature code cross reference" on page 323, for a list of CCIN numbers sorted by feature code. The feature code is used by marketing to report configurations and work with upgrades.

CCIN	Feat. code	Description
0047	0047	Device Parity RAID-6 All
0121	0121	#0121 Lower Unit in Rack Specify
0122	0122	#0122 Upper Unit in Rack Specify
0135	0135	Rear Cover - CEC only
0136	0136	Rear Cover - CEC with #7116
0145	0145	AIX Partition Specify
0150	0150	820 Base Processor
0151	0151	820 Base Processor
0152	0152	820 Base Processor
0165	0165	VHDCI Attachment
0226	0226	1 Gbps Ethernet Specify
0272	0272	Renovated by IBM
0290	0290	Ext Tape Attached via #5736,#5775
0297	0297	Model 250 Package - 2295
0298	0298	Model 250 Package - 2296
0299	0299	MES Conversion. Analysis for #5580, #5581
0329	0329	V.24/EIA232 80-ft Cable
0330	0330	V.24/EIA232 20-ft Cable
0331	0331	V.24/EIA232 50-ft Cable
0332	0332	V.24/EIA232 20-ft Enh Cable
0333	0333	V.24/EIA232 50-ft Enh Cable
0334	0334	V.24/EIA232 80-ft Enh Cable
0335	0335	V.36/EIA449 20-ft Cable
0336	0336	V.36/EIA449 50-ft Cable
0337	0337	V.36/EIA449 150-ft Cable
0338	0338	V.35 20-ft Cable
0339	0339	V.35 50-ft Cable
0340	0340	V.35 80-ft Cable
0341	0341	X.21 20-ft Cable
0342	0342	X.21 50-ft Cable
0343	1460	3m Copper HSL Cable
0344	0344	20-ft Comm Console Cable
0348	0348	V.24/EIA232 20-ft PCI Cable
0349	0349	V.24/EIA232 50-ft PCI Cable
0350	0350	V.24/EIA232 20-ft E PCI Cable
0351	0351	V.24/EIA232 50-ft E PCI Cable
0352	0352	V.24/EIA232 80-ft E PCI Cable
0353	0353	V.35 20-ft PCI Cable
0354	0354	V.35 50-ft PCI Cable
0355	0355	V.35 80-ft PCI Cable
0356	0356	V.36 20-ft PCI Cable
0357	0357	V.36 50-ft PCI Cable
0358	0358	V.36 150-ft PCI Cable
0359	0359	X.21 20-ft PCI Cable
0360	0360	X.21 50-ft PCI Cable
0361	1461	6m Copper HSL Cable
0362	0362	Comm Console PCI Cable
0364	0364	Parallel Cable
0365	0365	V.24/EIA232 80-ft PCI Cable
0368	1462	15m Copper HSL Cable
0380	0380	Remote Control Panel Cable
0381	0381	Remote Control Panel Cable
0382	0382	Remote Control Panel Cable
0383	0383	Remote Control Panel Cable
0446	0426	512 MB Server Memory
0446	0446	512 MB DDR Server Memory
0446	9726	Base 512 MB Server Memory

CCIN	Feat. code	Description
0447	0427	1 GB Server Memory
0447	0447	1 GB DDR Server Memory
0448	0428	2 GB Server Memory
0448	0448	2 GB DDR Server Memory
0530	0530	Software Version V5R3
0531	0531	#0531 i5/OS V5R3, V5R3M5 LIC
0532	0532	V5R4 OS, V5R4M0 LIC
0550	0550	#0550 iSeries Rack - 830 Rack
0551	0551	#0551 iSeries Rack - 270 Rack
0553	0553	#0553 iSeries 2.0 m Rack
0599	0599	Rack filler kit
1307	1307	1.75 m HSL-2 Cable
1308	1308	2.5 m HSL-2Cable
1468	1468	250 m Optical SPCN Cable
1469	1468	4.3m/200V/25A HD Wired EMEA
1470	1470	6m HSL Optical Cable
1471	1471	30m HSL Optical Cable
1472	1472	100m HSL Optical Cable
1473	1473	250m HSL Optical Cable
1474	1474	6m HSL to HSL-2 Cable
1475	1475	10m HSL to HSL-2 Cable
1477	1477	200V 16A 14 Ft PDU Cord
1481	1481	1.2m HSL-2 Cable
1482	1482	3.5m HSL-2 Cable
1483	1483	10m HSL-2 Cable
1485	1485	15m HSL-2 Cable
1500	1500	Interactive Capacity Card
1501	1501	Interactive Capacity Card
1502	1502	Interactive Capacity Card
1503	1503	Interactive Capacity Card
1504	1504	Interactive Capacity Card
1505	1505	Interactive Capacity Card
1506	1506	Interactive Capacity Card
1507	1507	Interactive Capacity Card
1508	1508	Interactive Capacity Card
1509	1509	Interactive Capacity Card
1510	1510	Interactive Capacity Card
1511	1511	Interactive Capacity Card
1512	1512	Interactive Capacity Card
1513	1513	Interactive Capacity Card
1514	1514	Interactive Capacity Card
1516	1516	Interactive Capacity Card
1517	1517	Interactive Capacity Card
1518	1518	Interactive Capacity Card
1519	1519	Interactive Capacity Card
1520	1520	Interactive Capacity Card
1521	1521	Interactive Capacity Card
1522	1522	Interactive Capacity Card
1523	1523	Interactive Capacity Card
1524	1524	Interactive Capacity Card
1525	1525	Interactive Capacity Card
1526	1526	Interactive Capacity Card
1527	1527	Interactive Capacity Card
1531	1531	Interactive Capacity Card
1532	1532	Interactive Capacity Card
1533	1533	Interactive Capacity Card
1534	1534	Interactive Capacity Card
1535	1535	Interactive Capacity Card

CCIN	Feat. code	Description
1536	1536	Interactive Capacity Card
1537	1537	Interactive Capacity Card
1540	1540	Interactive Capacity Card
1541	1541	Interactive Capacity Card
1542	1542	Interactive Capacity Card
1543	1543	Interactive Capacity Card
1544	1544	Interactive Capacity Card
1545	1545	Interactive Capacity Card
1546	1546	Interactive Capacity Card
1547	1547	Interactive Capacity Card
1548	1548	Interactive Capacity Card
1576	1576	Interactive Capacity Card
1577	1577	Interactive Capacity Card
1578	1578	Interactive Capacity Card
1579	1579	Interactive Capacity Card
1581	1581	Interactive Capacity Card
1583	1583	Interactive Capacity Card
1585	1585	Interactive Capacity Card
1587	1587	Interactive Capacity Card
1588	1588	Interactive Capacity Card
1591	1591	Interactive Capacity Card
1800	1800	HSL-2 Ports - 2 Copper
1801	1801	HSL-2 Ports - 2 Optical
1802	1802	IBT 2 port
1806	1806	HSL-2 Ports - 2 Copper
1807	1807	HSL-2 Ports - 2 Optical
2010	2010	1.6 SPPR CPU for Model 20S
2030	2030	0.7 SPPR CPU for Model 200
2031	2031	1.1 SPPR CPU for Model 200
2032	2032	1.6 SPPR CPU for Model 200
2040	2040	1.1 SPPR Processor
2041	2041	1.6 SPPR Processor
2042	2042	2.0 SPPR Processor
2043	2043	3.0 SPPR Processor
2044	2044	5.0 SPPR Processor
2050	2050	6.4 SPPR Processor
2051	2051	11.4 SPPR Processor
2052	2052	16.8 SPPR Processor
2058	4805	PCI Crypto Accelerator
2066	2066	Model 730 2-way Processor
2114	2114	External SCSI Y-Cable
2118	1850	VHDCI to P Converter Cable
2159	2159	Model 170 Processor
2160	2160	Model 170 Processor
2164	2164	Model 170 Processor
2176	2176	Model 170 Processor
2183	2183	Model 170 Processor
2207	2207	Model S40 8-way Processor
2208	2208	Model S40 12-way Processor
2248	2248	Model 270 Processor
2250	2250	Model 270 Processor
2252	2252	Model 270 Processor
2253	2253	Model 270 2-way Processor
2289	2289	Model 170 Processor
2290	2290	Model 170 Processor
2290	2298	Model 170 Processor Package 64 MB
2291	2291	Model 170 Processor
2291	2299	Model 170 Processor Package 64 MB

CCIN	Feat. code	Description
2292	2292	Model 170 Processor
2295	0297	Model 250 Package
2295	2295	Model 250 Processor
2296	0298	Model 250 Package
2296	2296	Model 250 Processor
2315	2315	Model SB2 8-way Processor
2316	2316	Model SB3 12-way Processor
2318	2318	Model SB3 24-way Processor
2341	2341	Model S40 ISV 12-way Processor
2349	2349	Model 830 4/8-way Processor
2351	2351	Model 830 1/8-way POD
2352	2352	Model 840 8/12-way POD
2353	2353	Model 840 12/18-way POD
2354	2354	Model 840 18/24-way POD
2383	2383	Model 170 Processor
2384	2384	Model 170 Processor
2385	2385	Model 170 Processor
2386	2386	Model 170 Processor
2388	2388	Model 170 2-way Processor
2395	2395	Model 820 Processor
2396	2396	Model 820 Processor
2397	2397	Model 820 2-way Processor
2398	2398	Model 820 4-way Processor
2400	2400	Model 830 2-way Processor
2402	2402	Model 830 4-way Processor
2403	2403	Model 830 8-way Processor
2407	2407	Dedicated Domino Processor
2408	2408	Dedicated Domino Processor
2409	2409	Dedicated Domino Processor (2-way)
2410	2410	100 Client Server Processor
2411	2411	3.0 SPPR Processor
2412	2412	6.1 SPPR Processor
2416	2416	Model 840 8/12-way POD
2417	2417	Model 840 12/18-way POD
2418	2418	Model 840 12-way Processor
2419	2419	Model 840 18/24-way POD
2420	2420	Model 840 24-way Processor
2422	2422	Dedicated Domino Processor
2423	2423	Dedicated Domino Processor
2424	1851	0.6m SCSI P-P Cable
2424	2424	Dedicated Domino 2-way Processor
2425	1852	2.5m SCSI P-P Cable
2425	2425	Dedicated Domino Processor
2426	2426	Dedicated Domino 2-way Processor
2427	2427	Dedicated Domino 4-way Processor
2431	2431	Model 270 Processor
2434	2434	Model 270 2-way Processor
2435	2435	Model 820 Processor
2436	2436	Model 820 Processor
2437	2437	Model 820 2-way Processor
2438	2438	Model 820 4-way Processor
2452	2452	Dedicated Domino Processor
2454	2454	Dedicated Domino 2-way Processor
2456	2456	Dedicated Domino Processor
2457	2457	Dedicated Domino 2-way Processor
2458	2458	Dedicated Domino 4-way Processor
2461	2461	Model 840 24-way Processor
2463	2463	Model 800 1-way Processor

CCIN	Feat. code	Description
2464	2464	Model 800 1-way Processor
2465	2465	Model 810 1-way Processor
2466	2466	Model 810 1-way Processor
2467	2467	Model 810 1-way Processor
2469	2469	Model 810 2-way Processor
2473	2473	Model 825 3/6-way Processor
2486	2486	Model 870 8/16-way Processor
2487	2487	Model 890 16/24-way Processor
2487	2497	Model 890 16/24-way Processor
2488	2488	Model 890 24/32-way Processor
2488	2498	Model 890 24/32-way Processor
2495	2495	Model 825 1/6-way Processor
2496	2496	Model 870 2/16-way Processor
2497	2497	Model 890 16/24-way Processor
2498	2498	Model 890 24/32-way Processor
2499	2499	Model 890 4/32-way Processor
2515	2515	C10 Floating Pt Processor
2516	2516	C20 Floating Pt Processor
2523	2523	D80 Processor
2525	2525	D02 Processor
2528	2528	16.8 SPPR CPU for Model F97
2530	2530	E04 Processor
2531	2413	E06 Processor
2533	2533	E20 Processor
2534	2534	E25 Processor
2536	2536	E35 Processor
2537	2537	E45 Processor
2539	2539	E02 Twinaxial
2540	2540	0.7 SPPR CPU for Model D35
2541	2541	D45 Processor
2542	2542	D50 Processor
2543	2543	D60 Processor
2544	2544	D70 Processor
2552	2552	C06 Processor
2553	2553	D06 Processor
2554	2554	D04 Processor
2555	2555	D10 Processor
2556	2556	D20 Processor
2557	2557	D25 Processor
2558	2558	C04 Processor 8 MB
2559	2559	E50 Processor
2560	2560	E60 Processor
2561	2561	E70 Sort Processor
2562	2562	E80 Sort Processor
2563	2563	E90 (2way) Sort
2568	2568	E95 (2way) Sort
2582	2582	F06 Processor
2583	2583	F25 Processor
2584	9584	ASCII Workstation Controller
2585	2414	F02 Processor
2585	9585	Twinaxial Workstation Controller
2586	2586	0.7 SPPR for F04
2587	2587	F10 Processor
2588	2588	F20 Processor
2591	2591	Ext. 1.44 GB Diskette Drive
2592	2592	F35 Processor
2593	2593	F45 Sort Processor
2594	2594	F50 Processor

CCIN	Feat. code	Description
2595	2595	F60 Sort Processor
2596	2596	F70 Processor 1-way
2597	2597	F80 Processor 2-way
2598	2598	F90 Processor 2-way
2600	2600	Magnetic Storage Controller
2601	2601	9346 Mag Tape Unit Controller
2602	2602	Processor Expansion
2602	2607	9348 Mag Tape Unit Attach
2604	2604	3422 3430 Mag Tape Subsys
2605	2605	ISDN Basic Rate Adapter
2608	2608	2440/9348 HCD Mag Tape Att
2609	2609	EIA 232/V.24 2-Line Adapt
2609	2654	EIA 232/V.24 2-Line 20E
2609	2655	EIA 232/V.24 2-Line 20
2609	2657	EIA 232/V.24 2-Line 50E
2609	2658	EIA 232/V.24 2-Line 50
2609	8863	EIA 232/V.24 2-Line 20E
2609	8866	EIA 232/V.24 2-Line 50E
2610	2610	X.21 2-Line Adapter
2610	2656	X.21 2-Line 20
2610	2659	X.21 2-Line 50
2611	2611	DASD Controller
2612	2612	EIA 232/V.24 1-Line Adapter
2612	9612	Standard EIA 232/V.24 1-Line/Ad
2613	2613	V.35 1-Line Adapter
2614	2614	X.21 1-Line Adapter
2617	2617	Ethernet/IEEE 802.3 CSMA/CD
2617	9617	Base Ethernet IOP
2618	2618	Fiber Distributed Data Adapt
2618	8664	Optional Base Fiber DD Intf
2619	2619	16/4 Mbps Token-Ring Adapter
2619	9619	Base 16/4 Mbps Token-Ring IOP
2620	2620	Cryptographic Processor
2621	2621	Removable Media Device Attach
2622	2622	3490 Magnetic Tape Attach
2623	2623	Six-Line Comm Controller
2623	9623	Standard Six Line Comm Controller
2624	2624	Storage Device Controller
2624	9624	Store Device Control Spec
2625	2625	Ethnet/IEEE 802.3 CSMA/CD
2626	2626	16/4 Mbps Token-Ring Adapter/A
2628	2628	Cryptographic Processor-Comm
2629	2629	LAN/WAN/Workstation IOP
2630	8505	I/O Card Unit Conversion
2634	2634	16/4 Mbps Token-Ring Adapter
2636	2636	16/4 Mbps Token-Ring Adapter
2637	9144	ASCII Workstation Controller
2637	9147	Standard MFIOP/ASCII WSC
2637	9150	Standard MFIOP/ASCII WSC
2638	9146	Standard MFIOP/Twinaxial WSC
2644	2644	34xx Magnetic Tape Attachment
2647	2647	9348 Model 2 Tape Attachment
2651	9651	Storage Device Controller
2654	8609	EIA 232/V.24 2-Line
2654	9609	Standard EIA 232/V.24 2-line
2661	9148	Standard MFIOP/Twinaxial WSC
2661	9151	Standard MFIOP/Twinaxial WSC
2661	9172	Twinaxial MFIOP

CCIN	Feat. code	Description
2663	2663	I/O Attachment Processor
2664	2664	Integrated Fax Adapter
2665	2665	Copper Dist Data Interface
2665	8665	Optional Base Shielded DD Intf
2666	2666	Frame Relay Adapter
2668	2668	AS/400 Wireless LAN Adapter
2669	2669	Shared Bus Interface Card
2670	2670	System Unit Expansion Tower (optical)
2671	2671	PCI Bus IOP
2672	2672	PCI Bus IOP
2673	2673	Optical Bus Adapter
2673	9673	Standard Optical Bus Adapter
2674	2674	Optical Bus Adapter
2680	2680	Optical Bus Receiver (266 Mbps)
2682	2682	Optical Bus Receiver (1063 Mbps)
2683	2683	266 Mbps OptiConnect Receiver
2685	2685	1063 Mbps OptiConnect Receive
2686	2686	Optical Link Processor (266 Mbps)
2688	2688	Optical Link Processor (1063 Mbps)
2691	2691	Optical Bus Adapt w/Token Ring
2691	9691	#9691 Base Bus Adapter HSL Copper
2692	2692	Optional Bus Adapt w/Ethernet
2693	2693	Optional Bus Adapt w/Token Ring
2694	2694	Optional Bus Adapt w/Ethernet
2695	2695	Optical Bus Adapter
2696	9696	Base Optical Bus Adapter
2699	2699	2-Line WAN IOA
2699	9699	Base 2-Line WAN IOA
2705	2705	M1 Filler Tray
2706	2706	M2 Terminator Tray
2713	2713	SPD I/O Regulator
2715	2715	Processor/Memory Regulator
2718	2718	PCI Magnetic Media Controller
2720	2720	PCI WAN/Twinaxial IOA
2720	9720	Base PCI WAN/Twinaxial IOA
2721	2721	PCI 2-Line WAN IOA
2721	9721	Base PCI 2-Line WAN IOA
2722	2722	PCI Twinaxial Workstation IOA
2723	2723	PCI Ethernet IOA
2723	4723	PCI 10 Mbps Ethernet IOA
2723	9723	Base Ethernet IOA
2724	2724	PCI 16/4 Mbps Token-Ring IOA
2724	9724	Base 16/4 Mbps Token-Ring IOA
2726	2726	PCI RAID Disk Unit Controller
2728	9728	Base PCI Disk Unit Controller
2729	2729	PCI Magnetic Media Controller
2730	2730	Programmable Regulator
2732	2732	PCI Serial HIPPI Adapter
2732	9732	Base HSL Ports - 8 Copper
2732	9733	Base HSL Ports - 8 Copper
2735	2735	Optical Bus Adapter
2736	2736	Optical Bus Adapter
2737	2737	PCI USB 1.1 Adapter
2737	9737	Base HSL Ports - 16 Copper
2738	2738	HSL Ports - 8 Copper
2739	2739	Optical Bus Adapter
2739	9739	Base Optical Bus Adapter
2740	2740	PCI RAID Disk Unit Controller

CCIN	Feat. code	Description
2740	9740	Base PCI RAID Disk Unit Controller
2741	2741	PCI RAID Disk Unit Controller
2742	0613	Linux Direct Attach-2742
2742	2742	PCI 2-Line WAN IOA
2743	0601	Linux Direct Attach-2743
2743	2743	PCI 1 Gbps Ethernet IOA
2744	0603	Linux Direct Attach-2744
2744	2744	PCI 100 Mbps Token-Ring IOA
2745	0398	Operations Console Package
2745	0608	Linux Direct Attach-4745
2745	2745	PCI 2-Line WAN IOA
2745	4745	PCI 2-Line WAN IOA
2745	9745	Base PCI 2-Line WAN IOA
2746	2746	PCI Twinaxial Workstation IOA
2746	4746	PCI Twinaxial Workstation IOA
2746	9746	Base PCI Twinaxial Workstation IOA
2748	0605	Linux Direct Attach-4748
2748	2748	PCI RAID Disk Unit Controller
2748	4748	PCI RAID Disk Unit Controller
2748	9748	Base PCI Disk Unit Controller
2749	2749	PCI Ultra Mag Media Controller
2750	2750	PCI ISDN BRI U IOA
2750	4750	#4750 PCI ISDN BRI U IOA
2751	2751	PCI ISDN BRI S/T IOA
2751	4751	PCI ISDN BRI S/T IOA
2754	2754	HSL Ports - 8 Copper
2754	2777	HSL Ports - 8 Copper
2754	9752	Base HSL Ports - 8 Copper
2754	9777	Base HSL Ports - 8 Copper
2755	2755	HSL Ports -16 Copper
2755	9755	Base HSL Ports -16 Copper
2757	0618	Linux Direct Attach-2757
2757	2757	PCI-X Ultra RAID Disk Ctrl
2758	2758	HSL Ports - 2 Optical/ 6 Copper
2758	2774	HSL Ports - 2 Optical/ 6 Copper
2758	9758	Base HSL Ports - 2 Optical/6 Cop
2758	9774	Base HSL Ports - 2 Optical/6 Cop
2759	2759	HSL Ports - 4 Optical/12 Copper
2759	9759	Base HSL Ports-4 Optical/12 Cop
2760	0602	Linux Direct Attach-2760
2760	2760	PCI 1 Gbps Ethernet UTP IOA
2761	2761	PCI Integrated Analog Modem
2761	4761	PCI Integrated Analog Modem
2763	0604	Linux Direct Attach-2763
2763	2763	PCI RAID Disk Unit Controller
2765	0611	Direct Attach 2765
2765	2765	PCI Fibre Channel Tape Controller
2766	0612	Linux Direct Attach-2766
2766	2766	PCI Fibre Channel Disk Controller
2767	9767	Base PCI Disk Unit Controller
2768	2768	PCI Magnetic Media Controller
2771	9771	Base PCI 2-Line WAN w/Modem
2772	0609	Linux Direct Attach - #2772
2772	0610	Linux Direct Attach - #2773
2772	2772	PCI Dual WAN/Modem IOA
2772	2773	PCI Dual WAN/Modem IOA (ANSI)
2773	0610	Linux Direct Attach - #2773
2776	2776	HSL-2 Ports - 8 Copper

CCIN	Feat. code	Description
2778	0606	Linux Direct Attach-4778
2778	2778	PCI RAID Disk Unit Controller
2778	4778	PCI RAID Disk Unit Controller
2778	9778	Base PCI RAID Disk Unit Controller
2780	0627	Linux Direct Attach-2780
2780	2780	PCI Ultra 4 SCSI Disk Ctrl
2782	0619	Linux Direct Attach-2782
2782	2782	PCI-X RAID Disk Unit Controller
2785	2785	HSL-2 Ports - 2 Copper
2785	9785	Base HSL-2 Ports - 2 Copper
2786	2786	HSL Ports - 2 Optical
2786	9786	Base HSL Ports - 2 Optical
2787	0626	Linux Direct Attach-2787
2788	2788	HSL Ports - 8 Optical
2789	2789	HSL Ports - 4 Optical
2789	9789	Base HSL Ports - 4 Optical
2793	0614	Linux Direct Attach-2793
2793	0615	Linux Direct Attach-2794
2793	2793	PCI 2-Line WAN w/Modem
2793	2794	PCI 2-Line WAN w/Modem (CIM)
2793	6803	PCI WAN for ECS
2793	6804	PCI WAN for ECS (CIM)
2793	9493	Base PCI WAN for ECS
2793	9494	Base PCI WAN for ECS (CIM)
2793	9793	Base PCI 2-Line WAN w/Modem
2793	9794	Base PCI 2-Line WAN w/Modem
2794	0615	Linux Direct Attach - #2794
2799	2799	#2799 PCI Integrated xSeries Server
2800	9800	Internal Disk Unit (640 MB)
2801	2801	1.96 GB Internal Disk Unit
2801	9801	Internal Disk Unit (1 GB)
2802	2802	2.0 GB Internal Disk Unit
2802	9802	Standard 2.0 GB Int Disk Unit
2805	0616	Linux Direct Attach-2805
2805	0617	Linux Direct Attach-2806
2805	2805	PCI Quad Modem IOA
2805	2806	PCI Quad Modem IOA (CIM)
2806	0617	Linux Direct Attach -0617 (CIM)
2806	2806	PCI Quad Modem IOA(CIM)
2809	2809	PCI LAN/WAN/Workstation IOP
2810	2810	LAN/WAN IOP
2811	2811	PCI 25 Mbps UTP ATM
2812	2812	PCI 45 Mbps Coax T3/DS3 ATM
2813	2813	PCI 155 Mbps MMF ATM
2813	2814	PCI 100 Mbps MMF ATM
2815	2815	PCI 155 Mbps UTP OC3 ATM
2815	4815	PCI 155 Mbps UTP OC3 ATM
2816	2816	PCI 155 Mbps MMF ATM
2816	4816	PCI 155 Mbps MMF ATM
2817	2817	PCI 155 Mbps MMF ATM
2818	2818	PCI 155 Mbps SMF OC3 ATM
2818	4818	PCI 155 Mbps SMF OC3 ATM
2819	2819	PCI 34 Mbps Coax E3 ATM
2824	2824	PCI LAN/WAN/Workstation IOP
2830	2830	Main Storage Expansion
2838	0607	Linux Direct Attach-4838
2838	2838	PCI 100/10 Mbps Ethernet IOA
2838	4838	PCI 100/10 Mbps Ethernet IOA

CCIN	Feat. code	Description
2838	9738	Base PCI 100/10 Mbps Ethernet
2842	0636	Graphics Adapter (GXT4500P)
2842	2842	PCI IOP
2843	2843	PCI IOP
2843	9943	Base PCI IOP
2844	2844	PCI IOP
2844	9844	Base PCI IOP
2847	2847	Fibre Channel IOP for SAN load source
2849	0623	Linux Direct Attach-2849
2849	0633	LANA1+ (GXT 135P)
2849	2849	PCI 100/10 Mbps Ethernet IOA
2849	9749	Base PCI 100/10 Ethernet IOA
2850	2850	Integrated PC Server 32 MB
2850	2851	PCI Integrated PC Server
2850	2852	PCI Integrated PC Server
2850	2854	PCI Integrated PC Server
2850	2857	PCI Integrated PC Server
2850	2858	FSIOA 128 MB Memory Keyboard Mouse
2850	2865	PCI Integ Netfinity Server
2850	2866	PCI Integ Netfinity Server
2850	2868	PCI Integ Netfinity Server
2853	2853	3450 0.66m system to device cable
2855	2855	3450 1.2m system to device cable
2856	2856	3450 1.2m system to device cable
2860	2860	16 MB IOP Memory
2861	1855	4-port EIA 232 Cable
2861	2861	32 MB IOP Memory
2862	2862	128 MB IOP Memory
2863	2863	Cable, Artic960HX
2864	2864	Cable, Artic960HX
2867	2867	256 MB IOP Memory
2877	2877	Cable H.100 BUS
2881	2881	Main Storage Expansion
2884	2884	Main Storage Expansion
2886	2886	Optical Bus Adapter
2886	9886	Base Optical Bus Adapter
2887	2887	HSL-2 Bus Adapter
2887	9887	Base HSL-2 Bus Adapter
2888	2888	HSL-2/RIO-G Ports - 2 Copper
2890	2790	PCI Integrated Netfinity Server
2890	2791	PCI Integrated xSeries Server
2890	2799	PCI Integ xSeries Server
2890	2890	PCI Integ Netfinity Server
2890	2891	PCI Integ xSeries Server
2890	2899	PCI Integ xSeries Server
2892	2792	PCI Integrated xSeries Server
2892	2892	PCI Integ xSeries Server
2892	4710	#4710 PCI Integrated xSeries Server
2892	4810	#4810 PCI Integrated xSeries Server
2892	9792	Base PCI Integ xSeries Server
2895	2795	128 MB Server Memory
2895	2895	128 MB Server Memory
2896	2796	256 MB Server Memory
2896	2896	256 MB Server Memory
2897	2797	1 GB Server Memory
2897	2897	1 GB Server Memory
2934	2934	Async Term/Printer Cable

CCIN	Feat. code	Description
2936	2936	Async Modem Cable-EIA232/188
2943	2943	8-port EIA232/422 Adapter
2944	0634	128-port ASYNC Adapter
2946	2946	622 MBS ADM Fiber Adpt
2947	2947	Artic960HX Adpt
2951	2951	Hermosa cable EIA232
2952	2952	Hermosa cable V.35
2953	2953	Hermosa V.36
2953	2954	Hermosa cable X.21
2962	0635	SDLC/X.25 - 2-port Adapter
3001	3001	32 MB Main Storage
3002	3000	Migrated 128 MB Main Storage
3002	3002	128 MB Main Storage
3002	3062	128 MB Main Storage
3003	3003	256 MB Main Storage
3005	3005	512 MB Main Storage
3005	3065	512 MB Main Storage
3006	3006	512 MB Main Storage
3006	3066	512 MB Main Storage
3007	3007	1 GB Main Storage
3007	3067	1 GB Main Storage
3009	3009	128 MB Main Storage
3015	3015	8 GB Main Storage
3016	3016	8 GB Main Storage
3017	3017	32 GB Main Storage
3018	3018	32 GB Main Storage
3020	3020	4 GB Main Storage
3021	3021	4 GB Main Storage
3022	3022	128 MB Main Storage
3024	3024	256 MB Main Storage
3025	3025	512 MB Main Storage
3026	3026	512 MB Main Storage
3027	3027	1 GB Main Storage
3029	3029	128 MB Main Storage
3032	3032	256 MB Main Storage
3033	3033	512 MB Main Storage
3034	3034	1 GB Main Storage
3035	3035	16 GB Main Storage
3036	3036	16 GB Main Storage
3037	3037	64 GB Main Storage PDIMM
3038	3038	64 GB Main Storage PDIMM
3042	3042	256 MB Main Storage
3043	3043	512 MB Main Storage
3044	3044	1024 MB Main Storage
3045	3045	1024 MB Main Storage
3046	3046	2048 MB Main Storage
3054	3054	4 MB Additional Main Storage
3055	3055	8 MB Additional Main Storage
3060	3060	16 MB Additional Main Storage
3061	3061	16 MB Additional Main Storage
3092	3092	256 MB Main Storage
3093	3093	512 MB Main Storage
3094	3094	1024 MB Main Storage
3095	3095	1024 MB Main Storage
3096	3096	2048 MB Main Storage
3100	3100	16 MB Main Storage
3101	3101	32 MB Main Storage
3102	3102	16 MB Main Storage

CCIN	Feat. code	Description
3103	3103	32 MB Main Storage
3103	4103	32 MB Main Storage
3104	3104	64 MB Main Storage
3104	4204	64 MB Main Storage
3104	9304	Standard 64 MB Main Storage
3108	3108	8 MB Main Storage
3109	3109	32 MB Main Storage
3110	3110	64 MB Main Storage
3110	8210	Optional 64 MB Main Storage
3110	9110	Standard 64 MB Main Storage
3116	3116	MFIOF Storage Expansion
3117	3117	8 MB Main Storage
3117	4117	8 MB Main Storage SIMM
3118	3118	16 MB Main Storage
3118	4118	16 MB Main Storage SIMM
3119	3119	8 MB Main Storage
3120	3120	8 MB Main Storage
3120	4120	8 MB Main Storage
3121	3121	8 MB Main Storage
3121	4121	8 MB Main Storage
3122	3122	32 MB Main Storage
3122	4122	32 MB Main Storage
3124	1873	Dwr to Dwr Serial Cable
3125	1874	Rack to Rack Serial Cable
3130	3130	32 MB Main Storage
3131	3131	64 MB Main Storage
3131	9231	Optional Base 64 MB Main Storage
3132	3132	128 MB Main Storage
3132	9232	Optional Base 128 MB Main Storage
3133	3133	64 MB Main Storage
3133	4133	64 MB Main Storage
3134	3134	128 MB Main Storage
3134	4134	128 MB Main Storage
3134	9234	Standard 128 MB Main Storage
3135	3135	256 MB Main Storage
3135	4135	256 MB Main Storage
3135	7135	Optional 256 MB Main Storage
3135	8135	Optional Base 256 MB Main Storage
3136	3136	256 MB Main Storage
3136	4136	256 MB Main Storage
3138	3138	64 MB Main Storage
3138	4138	64 MB Main Storage
3140	3140	8 MB Main Storage
3141	3141	16 MB Main Storage
3142	3142	32 MB Main Storage
3144	3144	8 MB Main Storage
3144	4144	8 MB Main Storage
3145	3145	16 MB Main Storage
3145	4145	16 MB Main Storage
3146	3146	32 MB Main Storage
3146	4146	32 MB Main Storage
3147	3147	32 MB Main Storage
3147	4147	32 MB Main Storage
3149	3149	128 MB Main Storage
3149	4149	128 MB Main Storage
3152	3152	32 MB Main Storage
3152	9252	Standard 32 MB Main Storage
3153	3153	64 MB Main Storage

CCIN	Feat. code	Description
3153	8253	Optional Base 64 MB Main Storage
3154	3154	128 MB Main Storage
3154	8254	Optional Base 128 MB Main Storage
3154	9254	Standard 128 MB Main Storage
3155	3155	256 MB Main Storage
3155	7255	Optional Base 256 MB Main Storage
3155	8255	Optional Base 256 MB Main Storage
3156	3156	64 MB Main Storage
3156	4156	64 MB Main Storage
3156	8156	Optional Base 64 MB Main Storage
3156	9156	Standard 64 MB Main Storage
3157	3157	128 MB Main Storage
3157	4157	128 MB Main Storage
3157	7157	Optional Base 128 MB Main Storage
3157	8157	Optional Base 128 MB Main Storage
3158	3158	256 MB Main Storage
3158	4158	256 MB Main Storage
3158	7158	Optional Base 256 MB Main Storage
3158	8158	Optional Base 256 MB Main Storage
3159	3159	8 MB Main Storage
3159	9159	Standard 8 MB Main Storage
3160	3160	16 MB Main Storage
3160	8160	Optional Addtl 16 MB Main Storage
3160	9160	Standard 16 MB (2 SIMM)
3161	3161	32 MB Main Storage
3161	4161	32 MB Main Storage
3161	9161	Standard 32 MB Main Storage
3162	3162	128 MB Main Storage
3162	9262	Standard 128 MB Main Storage
3163	3163	256 MB Main Storage
3163	7263	Optional Base 256 MB Main Storage
3163	9263	Standard 256 MB Main Storage
3164	3164	512 MB Main Storage
3164	7264	Optional Base 512 MB Main Storage
3164	8264	Optional Base 512 MB Main Storage
3165	3165	1024 MB Main Storage
3165	7265	Optional Base 1024 MB Main Storage
3165	8265	Optional Base 512 MB Main Storage
3166	3166	256 MB Main Storage
3166	7266	Optional Base 256 MB Main Storage
3166	9266	Standard 256 MB Main Storage
3172	3172	32 MB Main Storage (2 SIMMs)
3172	3182	32 MB Main Storage
3172	4172	32 MB Main Storage
3172	8172	Delt Price 32 MB
3172	9272	Standard 32 MB Main Storage
3172	9282	Standard 32 MB Main Storage
3179	3179	256 MB Main Storage
3179	9179	Base 256 MB Main Storage
3180	3180	512 MB Main Storage
3180	8180	Optional Base 512 MB Main Storage
3184	3184	32 MB Main Storage
3184	9184	Standard 32 MB Main Storage
3185	3185	64 MB Main Storage
3185	8185	Optional Base 64 MB Main Storage
3185	9185	Standard 64 MB Main Storage
3186	3186	128 MB Main Storage
3186	7186	Optional Base 128 MB Main Storage

CCIN	Feat. code	Description
3186	8186	Optional Base 128 MB Main Storage
3187	3187	256 MB Main Storage
3187	7187	Optional Base 256 MB Main Storage
3187	8187	Optional Base 256 MB Main Storage
3189	3189	128 MB Main Storage
3190	3190	256 MB Main Storage
3190	9190	Base 256 MB Main Storage
3191	3191	512 MB Main Storage
3191	8191	Optional Base 512 MB Main Storage
3192	3192	1024 MB Main Storage
3192	8192	Optional Base 1024 MB Main Storage
3193	3193	2048 MB Main Storage
3193	8193	Optional Base 2048 MB Main Storage
3195	3195	4096 MB Main Storage
3196	3196	8192 MB Main Storage
3197	3197	1024 MB Main Storage
3198	3198	2048 MB Main Storage
3273	1893	36.4 GB 10k rpm Disk Unit
3274	1894	73.4 GB 10k rpm Disk Unit
3275	1895	146.8 GB 10k rpm Disk Unit
3277	1896	36.4 GB 15k rpm Disk Unit
3278	1897	73.4 GB 15k rpm Disk Unit
3279	1898	146.8 GB Disk Unit
3612	3612	1024 MB Main Storage
3613	3613	2048 MB Main Storage
3614	3614	4096 MB Main Storage
3628	3628	Black P260/P275 Color
3636	1876	L200 Flat Panel Monitor
3637	3637	T541H/L150PTFT Color
3638	3638	Black C220P Color Monitor
3639	3639	Black L170P TFT Display
3641	3641	T115 TFT 15" Color Display
3643	3643	T120 TFT 20" Color Display
3644	3644	T119 TFT 19" Color Display
3645	3645	T117 TFT 17" Color Display
3925	1875	Serial Port Converter Cable
4010	4010	4 MB Write Cache
4011	4011	8 MB Data Store
4012	4012	32 MB Data Store
4104	4104	4 MB Main Storage
4104	9904	4 MB Main Storage
4114	4114	4 MB Main Storage Expansion
4263	4263	Direct Attach Tape Cables
4326	4326	35.16 GB 15k rpm Disk Unit
4326	7508	Quantity 150 of #4326
4327	4327	70.56 GB 15k rpm Disk Unit
4327	7509	Quantity 150 of #4327
4328	4328	141.12 GB15k rpm Disk Unit
4328	7510	Quantity 150 of #4328
4332	4332	Fibre Channel Loop Ctr
4690	4690	Rack Status Beacon Assem
4691	4691	Rack Status Beacon Cable
4692	4692	Junction Box Cable
4693	4693	Rack Beacon Junction box
4758	4800	PCI Crypto Coprocessor
4758	4801	PCI Crypto Coprocessor
4758	4802	PCI Crypto Coprocessor
4764	4806	PCI-X Cryptographic Coprocessor

CCIN	Feat. code	Description
4812	4811	#4811 PCI Integrated xSeries Server
4812	4812	#4812 PCI Integrated xSeries Server
4812	4813	#4813 PCI Integrated xSeries Server
4953	4953	155 MBps ATM UTP Adapter
4957	4957	155 MBps ATM Fiber Adapter
4959	4959	4/16 Token ring adpt/
4960	4960	Crypto SSL HW Accelerator
4961	0637	100/10 Mbps 4-port Ethernet Adapter
4961	4961	240V, 6ft, 30A Line Cord
4962	4962	Ethernet/LAN Encryption
4963	4963	Cryptographic Coprocessor
5033	5033	#5033 Migration Tower I
5034	5034	#5034 Migration Tower I
5035	5035	#5035 Migration Tower I
5052	8052	Optional 16 Disk Unit Expansion
5066	0565	#5065 Equivalent
5066	5066	1.8 M I/O Tower
5078	0578	PCI Expansion Unit in Rack
5078	5078	PCI Expansion Unit
5079	0574	#5074 Equivalent
5079	5079	1.8 M I/O Tower
5088	0588	PCI-X Expansion Unit in Rack
5088	5088	PCI-X Expansion Unit
5094	0694	#5094 Equivalent
5094	5094	PCI-X Expansion Tower
5095	0595	PCI-X Tower Unit in Rack
5097	5097	1.8M I/O Rack
5111	5111	#5111 30 Disk Expansion with Dual Line Cord
5121	5121	Power Regulator Card
5130	5130	Tower Attach Power (RISC)
5133	5133	Feature Power Supply
5133	5134	Feature Power Supply
5135	5135	Feature Power Supply
5136	5136	Feature Power Supply
5140	5140	Regulator
5141	5141	3.6V I/O Regulator
5142	5142	Tower Attach Power
5143	5143	Feature Power Supply (400W)
5144	5144	BBU External (Optional)
5145	5145	BBU Internal (Optional)
5146	5146	Redundant Power (Bulk Reg)
5147	5147	Feature Power - 560W
5148	5148	Addtnl Battery Backup Internal
5149	5149	Redundant Power (Bulk Reg)
5150	5150	Battery Backup (External)
5151	5151	Power Supply (650 Watts)
5152	5152	Feature Power Supply (500W)
5153	5153	Redundant Power Supplies
5156	5156	#5156 Redundant Power and Cooling
5157	5157	#5157 Feature Power Supply
5159	5159	850 W Power Supply
5160	5160	#5160 Power Distribution Unit
5161	5161	#5161 Power Distribution Unit
5162	5162	#5162 Power Distribution Unit
5163	5163	Power Dist Unit 3 Phase PDU
5228	8954	Model 520 1-way Processor
5229	5229	Model 520 2-way Processor

CCIN	Feat. code	Description
5229	8955	Model 520 2-way Processor
5237	8958	Model 550 1/4-way Processor
5700	0620	Linux Direct Attach-5700
5700	5700	#5700 PCI 1 Gbps Ethernet IOA
5700	6800	PCI 1 Gbps Ethernet IOA
5701	0621	Linux Direct Attach-5701
5701	5701	PCI 1 Gbps Ethernet UTP IOA
5701	6801	PCI 1 Gbps Ethernet UTP IOA
5702	0624	Linux Direct Attach-5702
5702	0645	Direct Attach 5712
5702	5702	#5702 PCI-X Ultra Tape Controller
5702	5705	#5705 PCI-X Tape/DASD Controller
5702	5712	Ultra320 SCSI
5702	5715	PCI-X Tape/DASD Controller
5703	0628	Linux Direct Attach-5703
5703	5703	PCI-X RAID Disk Controller
5704	0625	Linux Direct Attach-5704
5706	0643	Linux Direct Attach-5706
5706	5706	10/100/1000 Mbps Ethernet Fiber
5706	5706	Dual Port Gigabit Ethernet
5707	0644	Linux Direct Attach-5707
5707	5707	10/100/1000 Mbps Ethernet UTP
5707	5707	PCI 1 Gbps Ethrnt 2- port
5708	5580	RAID Disk Unit Controller 2780 with auxiliary Write Cache
5708	5581	RAID Disk Unit Controller 2757 with auxiliary Write Cache
5709	5709	Ultra320 SCSI Raid
5716	0646	Directect Attach 5716
5718	5718	10 GB Ethernet (Fiber)
5727	9510	Base Integrated Cache - 40 MB
6001	6001	SPCN Power Cable - 2 m
6006	6006	SPCN Power Cable - 3 m
6007	6007	SPCN Power Cable - 15 m
6008	6008	SPCN Power Cable - 6 m
6029	6029	SPCN Power Cable - 30 m
6040	6040	Twinaxial Workstation Controller
6041	6041	ASCII Workstation Controller
6050	6050	Twinaxial Workstation Controller
6050	9050	Base Twinaxial Workstation Controller
6053	9053	Standard Twinaxial WSC Specify
6054	6054	Local Talk Controller
6054	8054	LocalTalk Adapter
6054	9054	Standard LocalTalk Controller
6068	6068	Opt Front Door for 1.8m Rack
6080	7841	Ruggedize Rack Pack
6100	6100	Disk Unit (315 MB)
6100	9100	315 MB Disk Unit Relocation
6102	9102	Standard 320 MB Disk Unit
6103	6103	Single Disk Unit (400 MB)
6103	9103	Standard 400 MB Disk Unit
6104	6126	Base DASD Replace (988 MB)
6104	7840	Side-by-side for 1.8m Racks
6104	9104	Standard 988 MB Disk Unit
6105	1105	Single Disk Unit (320 MB) Kit
6105	1200	Single Disk Unit (320 MB) Kit
6105	6105	Single Disk Unit (320 MB)
6105	6108	Additional Dual Disk (640 MB)

CCIN	Feat. code	Description
6105	9106	Standard Dual Disk (640 MB)
6107	1107	Single Disk Unit (400 MB) Kit
6107	1201	Single Disk Unit (400 MB) Kit
6107	6107	Single Disk Unit (400 MB)
6107	6120	Dual Disk Unit (800 MB)
6107	6121	Additional Dual Disk (800 MB)
6107	9120	Standard Dual Disk (800 MB)
6109	1109	Single Disk Unit (988 MB) Kit
6109	1202	Single Disk Unit (988 MB) Kit
6109	1210	Additional Disk Unit (988 MB)
6109	6109	Single Disk Unit (988 MB)
6109	6123	Additional Dual Disk (1976 MB)
6109	6124	Base DASD Upgrade (1976 MB)
6109	6125	Base DASD Replace (988 MB)
6109	6127	Base DASD Replace (1976 MB)
6109	8123	Dual Disk Unit (1976 MB)
6109	9109	Standard 988 MB Disk Unit Spec
6110	6110	Magnetic Storage Dev Controller
6110	8110	Standard Mag Storage Controller
6111	6111	Magnetic Storage Dev Controller
6111	8111	Standard Mag Storage Controller
6112	6112	Magnetic Storage Device Controller
6120	1889	80 GB VXA-2 Tape Drive
6122	9122	Standard 851 MB Disk Unit (RPQ)
6134	6134	60 GB 8 mm Tape Unit
6140	6140	Twinaxial Workstation Controller
6140	9140	Twinaxial Workstation Control
6141	6141	ASCII Workstation Controller
6141	9141	ASCII Workstation Control
6146	6146	Diskette Adapter
6147	6147	Diskette Adapter
6148	6148	8-Port Twinaxial Expansion
6149	6149	16/4 Mbps Token-Ring IOA
6149	9249	Base 16/4 Mbps Token-Ring IOA
6150	6150	Three-Line Communication Controller
6151	6151	X.21 1-Line 20
6151	6171	X.21 1-Line 50
6152	6152	EIA 232/V.24 Adapter
6152	6154	EIA 232/V.24 1-Line 20E
6152	6155	EIA 232/V.24 1-Line 20
6152	6174	EIA 232/V.24 1-Line 50E
6152	6175	EIA 232/V.24 1-Line 50
6152	9862	EIA 232/V.24 1-Line 20E
6152	9865	EIA 232/V.24 1-Line50E
6153	6153	V.35 1-Line (20-ft Cable)
6153	6173	V.35 1-Line (50-ft Cable)
6160	6160	Token-Ring Network Adapter
6180	6180	Twinaxial Workstation IOA
6180	9280	Base Twinaxial WSC
6181	6181	Ethernet/IEEE 802.3 IOA
6181	9381	Base Ethernet/IEEE 802.3 IOA
6183	6183	6 port ASCII IOA
6202	6203	PCI Ultra3 SCSI Adapter
6204	6204	Differential SCSI Adapter
6230	0638	SSA (40 MBps) Adapter
6231	0639	128 MB DIMM & CD-ROM
6235	0640	Fast Write Cache Option
6246	6246	1.8m Rack Trim Kit

CCIN	Feat. code	Description
6258	6258	36 GB 4 mm Tape Unit
6312	6312	Quad Digital Trunk Adapter
6320	9520	Standard CD-ROM
6321	4425	CD-ROM
6321	4525	CD-ROM
6321	4625	CD-ROM
6321	6325	CD-ROM
6321	6425	CD-ROM
6330	4430	DVD-RAM
6330	4530	DVD-RAM
6330	4630	DVD-RAM
6331	5751	DVD-RAM
6333	4533	DVD-RAM
6333	4633	DVD
6333	5752	DVD-RAM
6335	1262	840 MB QIC-3040-MC
6335	1335	6335 External Conversion Kit
6335	6335	840 MB QIC-mini Tape Unit
6335	6365	840 MB QIC-mini Tape External
6336	4431	DVD-ROM
6336	4531	DVD-ROM
6336	4631	DVD-ROM
6337	2640	DVD-ROM Slimline Drive
6337	5750	DVD-ROM - Slim Line
6340	6340	13 GB QIC mini Tape Unit
6341	6341	120 MB ¼-in Cartridge Tape
6341	9341	Standard 120 MB ¼-inch Tape
6342	6342	525 MB ¼-inch Cartridge Tape
6342	8342	525 MB ¼-inch Cartridge Tape
6342	9342	Standard 525 MB ¼-inch Tape
6343	5343	Base Tape Replace (1.2 GB)
6343	6343	1.2 GB ¼-inch Cartridge Tape
6343	7343	1.2 GB ¼-inch Cartridge Tape
6343	8343	1.2 GB ¼-inch Cartridge Tape
6343	9343	Standard 1.2 GB ¼-inch Tape
6344	6344	2.5 GB ¼-in Cartridge Tape
6344	7344	2.5 GB ¼-in Cartridge Tape
6344	8344	2.5 GB ¼-inch Cartridge Tape
6345	6345	13 GB ¼-in Cartridge Tape
6345	8345	13 GB ¼-inch Cartridge Tape
6346	6346	120 MB ¼-in Cartridge Tape
6347	6347	525 MB ¼-in Cartridge Tape
6347	7347	Base Tape Upgrade (525 MB)
6347	8347	525 MB ¼-inch Cartridge Tape
6347	9347	Standard 525 MB ¼-inch Tape
6348	5348	Base Tape Replace (1.2 GB)
6348	6348	1.2 GB ¼-in Cartridge Tape
6348	7348	1.2 GB ¼-in Cartridge Tape
6348	8348	1.2 GB ¼-inch Cartridge Tape
6348	9348	Standard 1.2 GB ¼-inch-inch Tape
6349	5349	Base Tape Replace (2.5 GB)
6349	6349	2.5 GB ¼-in Cartridge Tape
6349	7349	2.5 GB ¼-in Cartridge Tape
6349	8349	2.5 GB ¼-in Cartridge Tape
6350	6350	13 GB ¼-in Cartridge Tape
6366	6366	120 MB ¼-in Cartridge Tape
6366	6367	525 MB ¼-in Cartridge Tape
6368	6368	1.2 GB ¼-inch Cartridge Tape

CCIN	Feat. code	Description
6369	6369	2.5 GB ¼-inch Cartridge Tape
6370	6370	13 GB ¼-in Cartridge Tape
6378	1250	525 MB ¼-inch Tape Kit
6378	1378	525 MB ¼-inch Cart Tape Kit
6379	1251	1.2 GB ¼-inch Tape Kit
6379	1349	1.2 GB ¼-inch Tape Kit
6379	1379	1.2 GB ¼-inch Cart Tape Kit
6380	1252	2.5 GB ¼-inch Tape Kit
6380	1260	2.5 GB ¼-inch Tape
6380	1350™	2.5 GB ¼-inch Tape Kit
6380	1380	2.5 GB ¼-inch Cart Tape Kit
6380	6380	2.5 GB ¼-inch Cartridge Tape
6380	6480	2.5 GB ¼-inch Cart Tape
6380	9380	2.5 GB ¼-inch Cart Tape
6385	1355	13.0 GB ¼-inch Tape Kit
6385	6385	13 GB ¼-inch Cartridge Tape
6385	6485	13 GB ¼-inch Cartridge Tape
6387	4487	50 GB ¼-inch Cartridge Tape Device
6387	4587	50 GB ¼-inch Cartridge Tape Device
6390	1261	7.0 GB 8 mm Cart Tape
6390	1360	7.0 GB 8 mm Cartridge Tape Kit
6390	6390	7 GB 8 mm Cartridge Tape Unit
6390	6490	7 GB 8 mm Cartridge Tape
6500	6500	Disk Controller
6501	6501	Tape/Disk Device Controller
6502	6502	Disk Unit Controller for RAID
6502	6522	Disk Unit Cntrlr for RAID
6506	6516	16 MB One-Port FSIOP
6506	6517	32 MB One-Port FSIOP
6506	6518	48 MB One-Port FSIOP
6506	6519	64 MB One-Port FSIOP
6506	6526	16 MB 2-Port FSIOP
6506	6527	32 MB 2-Port FSIOP
6506	6528	48 MB 2-Port FSIOP
6506	6529	64 MB 2-Port FSIOP
6506	8716	Optional 16 MB 1-Port FSIOP
6506	8717	Optional 32 MB 1-Port FSIOP
6506	8718	Optional 48 MB 1-Port FSIOP
6506	8719	Optional 64 MB 1-Port FSIOP
6506	8726	Optional 16 MB 2-Port FSIOP
6506	8727	Optional 32 MB 2-Port FSIOP
6506	8728	Optional 48 MB 2-Port FSIOP
6506	8729	Optional 64 MB 2-Port FSIOP
6509	6509	Additional 16 MB FSIOP Memory
6512	6512	Disk Unit Controller for RAID
6513	6513	Internal Tape Device Controller
6517	9517	Standard File Server 32 MB 1 Port
6520	6520	Upgrade 1 to 2 Port FSIOP
6529	9529	Standard File Server 64 MB 2 Port
6530	6523	Disk Unit Controller
6530	6530	Storage Device Controller
6532	6532	RAID Disk Unit Controller
6533	6533	RAID Disk Unit Controller
6534	6534	Magnetic Media Controller
6535	6536	SSA Disk Unit Controller
6535	6537	SSA RAID Disk Unit Controller
6580	6580	Optional Rack Security Kit
6586	6586	Modem Tray for 19-Inch Rack

CCIN	Feat. code	Description
6587	6587	Model 520 Rear Cover
6601	6601	Single Disk Unit (1031 MB)
6601	6701	Base Disk Replace (1.0 GB)
6601	9601	Standard 1.0 GB Disk Unit
6602	1203	Single Disk Unit (1031 MB) Kit
6602	1211	Additional Disk Unit (1.031 GB)
6602	1213	Standard Disk Unit (1.031 GB, 2 byte)
6602	1312	1-byte 1.03 GB Disk Unit Kit
6602	1322	2-byte 1.03 GB Disk Unit Kit
6602	1602	Single Disk Unit Kit (1.03 GB)
6602	4211	Addt Disk Unit (1.031 GB)
6602	4652	Single Disk Unit (1031 MB)
6602	6602	Single Disk Unit (1031 MB)
6602	6612	Dual Disk Unit (2.0 GB)
6602	6652	Additional Disk Unit (1.03 GB)
6602	6802	Base Disk Replacement (1.0 GB)
6602	6812	Base Disk Replacement (2.0 GB)
6602	8612	Base 2.0 GB Dual Disk Unit
6602	9602	Standard 1.0 GB Disk Unit
6602	9652	Standard Disk Unit (1.031 GB, 2 byte)
6603	1204	Single Disk Unit (1967 MB) Kit
6603	1212	Additional Disk Unit (1967 MB)
6603	1214	Optional Base Disk Unit (1.967 GB, 2b)
6603	1313	1-byte 1.96 GB Disk Unit Kit
6603	1323	2-byte 1.96 GB Disk Unit Kit
6603	1603	Single Disk Unit Kit (1.96 GB)
6603	4212	Addt Disk Unit (1967 MB)
6603	4650	Additional Disk Unit (1.967 GB, reg)
6603	6603	Single Disk Unit (1967 MB)
6603	6613	Dual Disk Unit (4 GB)
6603	6650	Additional Disk Unit (1.96 GB)
6603	7613	Base DASD Replace (3934 MB)
6603	8613	Base DASD Upgrade (3934 MB)
6603	8650	Optional Disk Unit (1.967 GB, 2 byte)
6605	1205	Additional 1.031 GB Disk Unit
6605	1325	2-byte 1.03 GB Disk Unit Kit
6605	4205	Addt Disk Unit (1.031 GB)
6605	4605	Addt Disk Unit (1.031 GB, reg)
6605	6605	1.03 GB Disk Unit
6605	9605	Standard 1.031 GB Disk Unit
6605	9705	Standard 1.031 GB Disk Unit regulated
6606	1206	Additional 1.967 GB Disk Unit
6606	1326	2-byte 1.96 GB Disk Unit Kit
6606	1336	2-byte 1.96 GB Disk Unit Kit
6606	4206	Addt Disk Unit (1.967 GB)
6606	4606	Single Disk Unit (1967 MB)
6606	6606	1.96 GB Disk Unit
6606	6806	1.96 GB Disk Unit
6606	6906	1.96 GB Disk Unit
6606	8606	Single Disk Unit (1967 MB)
6606	8706	Optional Base Disk Unit (1.967 GB)
6606	9606	Base 1.96 GB Disk Unit
6607	1207	Additional 4.194 GB Disk Unit
6607	1327	2-byte 4.19 GB Disk Unit Kit
6607	1337	2-byte 4.19 GB Disk Unit Kit
6607	4207	Addt Disk Unit (4.194 GB)
6607	4308	4.19 GB Disk Unit
6607	4607	Addt Disk Unit (4.194 GB, reg)

CCIN	Feat. code	Description
6607	6607	4.19 GB Disk Unit
6607	6807	4.19 GB Disk Unit
6607	6907	4.19 GB Disk Unit
6607	7607	Optional Base 4.19 GB Disk Unit
6607	8607	Optional Base DASD (4.194 GB, reg)
6607	8707	Optional Base Disk Unit (4.194 GB)
6607	9707	Base 4.19 GB Disk Unit
6607	9907	Base 4.19 GB Disk Unit
6616	6616	Integrated PC Server
6617	6617	Integrated PC Server
6617	6618	Integrated Netfinity Server
6713	1333	2-byte 8.58 GB Disk Unit Kit
6713	4314	8.58 GB Disk Unit
6713	6713	8.58 GB Disk Unit
6713	6813	8.58 GB Disk Unit
6713	7500	Quantity 150 of #4314
6713	7713	Optional Base 8.58 GB Disk Unit
6713	8713	Optional Base 8.58 GB Disk Unit
6713	8813	Optional Base 8.58 GB Disk Unit
6713	9313	Base 8.58 GB Disk Unit
6714	1334	2-byte 17.54 GB Disk Unit Kit
6714	4324	17.54 GB Disk Unit
6714	6714	17.54 GB Disk Unit
6714	6824	17.54 GB Disk Unit
6714	7503	Quantity 150 of #4324
6714	8714	Optional Base 17.54 GB Disk Unit
6714	8824	Optional Base 17.54 GB Disk Unit
6714	8924	Optional Base 17.54 GB Disk Unit
6717	4317	8.58 GB 10k rpm Disk Unit
6717	6717	8.58 GB 10k rpm Disk Unit
6717	6817	8.58 GB 10k rpm Disk Unit
6717	7501	Quantity 150 of #4317
6717	8617	Optional Base 8.58 GB 10k rpm Disk
6717	8817	Optional Base 8.58 GB 10k rpm Disk
6717	8917	Optional Base 8.58 GB 10k rpm Disk
6718	4318	17.54 GB 10k rpm Disk Unit
6718	6718	17.54 GB 10k rpm Disk Unit
6718	6818	17.54 GB 10k rpm Disk Unit
6718	7502	Quantity 150 of #4318
6718	8618	Optional Base 17 GB 10k rpm Disk
6718	8818	Optional Base 17 GB 10k rpm Disk
6718	8918	Optional Base 17 GB 10k rpm Disk
6719	4319	35.16 GB 10k rpm Disk Unit
6719	7504	Quantity 150 of #4319
6731	4331	1.6 GB Read Cache Device
6731	6831	1.6 GB Read Cache Device
6750	6750	MFIOP
6751	9751	Base MFIOP with RAID
6752	6752	MFIOP
6753	6753	MFIOP
6753	9753	Base MFIOP
6754	9754	Base MFIOP with RAID
6831	6831	1.6 GB Read Cache Device
6863	6863	System i5 Slim-Line Doors
6864	6864	System i5 Acoustic Doors
7000	9000	Panel Keylock Feature
7104	7104	System Unit Expansion
7116	9116	High Performance CD Enable

CCIN	Feat. code	Description
7117	9117	Expansion Unit 1
7126	9126	Standard Mixed Disk Enabler
7128	7128	#7128 DASD Expansion Unit
7130	7130	#7130 Expansion Unit Tape Cage
7147	7147	Value Edition for #09XX
7180	7180	Acoustic Front Door
7181	7181	Easy-Access Front Cover
7182	7182	520 Rack Mount
7183	7183	550 Rack Mount
7188	7188	Power Disk Unit - Side Mount
7194	7194	Easy-Access Front Cover
7197	7197	570 Front Bezel
7198	7198	Adjustable Depth Rack Rails
7199	7199	Acoustic Front Door
7256	7256	520 Enterprise Enablement
7257	7257	550 Enterprise Enablement
7258	7258	570 Full Enterprise Enable
7259	7259	595 Full Enterprise Enable
7260	7260	570 Enterprise Enablement
7261	7261	595 Enterprise Enablement
7307	7307	Dual I/O Unit Enclosure
7320	7320	520 One Processor Activation
7323	7323	550 One Processor Activation
7337	7373	HA Edition for #0906
7341	7341	550 On/Off Proc Day Billing
7354	7354	Accelerator for System i5
7355	7355	Accelerator for System i5
7357	7357	Accelerator for System i5
7366	7366	Solution Edition for #0906
7390	7390	Model 520 Value/Express Edition
7391	7391	Model 520 Value/Express Edition
7391	7393	Model 520 Value/Express Edition
7392	7392	Model 520 Value/Express Edition
7392	7394	Model 520 Value/Express Edition
7395	7395	Model 520 Value/Express Edition
7396	7396	Model 520 Value/Express Edition
7397	7397	Model 520 Value/Express Edition
7400	7400	Model 800 Value Edition
7404	7404	Model 810 Standard Edition
7404	7404	Package Feature
7406	7406	Model 810 Enterprise Edition
7406	7406	Package Feature
7407	7407	Model 810 Standard/Domino Edition
7408	7408	Model 800 Advanced Edition
7409	7409	Model 810 Enterprise Edition
7410	7410	Model 810 Standard/Domino Edition
7412	7412	Model 810 Enterprise Edition
7416	7416	Model 825 Standard/Domino Edition
7418	7418	Model 825 Enterprise Edition
7418	7434	Model 825 High Availability Edition
7419	7419	Model 870 Standard Edition
7421	7421	Model 870 Enterprise Edition
7421	7436	Model 870 High Availability Edition
7422	7422	Model 890 Standard Edition
7424	7424	Model 890 Enterprise Edition
7424	7437	Model 890 High Availability Edition
7425	7425	Model 890 Standard Edition
7427	7427	Model 890 Enterprise Edition

CCIN	Feat. code	Description
7427	7438	Model 890 High Availability Edition
7428	7428	Model 810 Standard/Domino Edition
7429	7429	Model 520 Express Config
7430	7430	Model 810 Enterprise Edition
7431	7431	Model 870 Standard Edition
7433	7433	Model 870 Enterprise Edition
7433	7435	Model 870 High Availability Edition
7439	7439	Model 870 Capacity BackUp Edition
7440	7440	Model 870 Capacity BackUp Edition
7441	7441	Model 890 Capacity BackUp Edition
7445	7445	Model 810 High Availability Edition
7446	7446	Model 810 High Availability Edition
7447	7447	Model 810 High Availability Edition
7448	7448	Model 810 High Availability Edition
7450	7411	Model 520 Express Config
7450	7413	Model 520 Express Config
7450	7417	Model 520 Express Config
7450	7450	Model 520 Value/Express Edition
7451	7414	Model 520 Express Config
7451	7420	Model 520 Express Config
7451	7451	Model 520 Value/Express Edition
7452	7452	Model 520 Value/Express Edition
7452	7552	Model 520 High Availability Edition
7453	7453	Model 520 Enterprise Edition
7454	7454	Model 520 Standard Edition
7455	7455	Model 520 Enterprise Edition
7456	7456	Model 520 Standard Edition
7457	7457	Model 520 Enterprise Edition
7458	7458	Model 520 Standard Edition
7459	7459	Model 520 Enterprise Edition
7462	7462	Model 550 Standard Edition
7463	7463	Model 550 Enterprise Edition
7469	7469	Model 570 0/4-way Standard Edition
7470	7470	Model 570 0/4-way Enterprise Edition
7471	7471	Model 570 0/8-way Standard Edition
7472	7472	Model 570 0/8-way Enterprise Edition
7473	7473	Model 570 0/12-way Standard Edition
7474	7474	Model 570 0/12-way Enterprise Edition
7475	7475	Model 570 0/16-way Standard Edition
7476	7476	Model 570 0/16-way Enterprise Edition
7480	7480	Standard Edition for 8966
7481	7481	Enterprise Edition for 8966
7481	7580	HA Edition for #0940
7482	7482	Standard Edition for 8966
7483	7483	Enterprise Edition for 8966
7483	7581	HA Edition for #0941
7484	7484	Model 59 32/48-way Standard Edition
7485	7485	Model 595 32/48-way Enterprise Edition
7486	7486	Standard Edition for 8966
7487	7487	Enterprise Edition for 8966
7487	7583	HA Edition for #0943
7488	7488	Model 570 0/2-way Standard Edition
7489	7489	Model 570 0/2-way Enterprise Edition
7490	7490	Model 570 0/2-way Standard Edition
7491	7491	Model 570 0/2-way Enterprise Edition
7494	7494	Model 570 2/4-way Standard Edition
7495	7495	Model 570 2/4-way Enterprise Edition

CCIN	Feat. code	Description
7496	7496	Model 595 8/16-way Standard Edition
7497	7497	Model 595 8/16-way Enterprise Edition
7498	7498	Model 59 16/32-way Standard Edition
7499	7499	Model 595 16/32-way Enterprise Edition
7530	7530	Model 5501/4-way Domino
7531	7531	Model 5501/4-way Solution E1
7532	7532	Model 5501/4-way CRM (Clear Tech w/Domino)
7533	7533	Model 5501/4-way SAP 2-way
7534	7534	Model 5501/4-way SAP 4-way
7541	7541	Model 520 Solution Edition
7553	7553	Model 520 High Availability Edition
7554	7554	Model 520 High Availability Edition
7555	7555	Model 520 High Availability Edition
7558	7558	Model 5501/4-way Solution
7559	7559	Model 570 High Availability Edition
7560	7560	Model 570 High Availability Edition
7561	7561	Model 570 High Availability Edition
7562	7562	Model 570 High Availability Edition
7563	7563	Model 570 High Availability Edition
7570	7570	Model 570 2/16-way CBU Edition
7590	7590	CBU Edition for #0944
7618	7618	570 One Processor Activation
7620	7620	520 On/Off Proc Enablement
7621	7621	520 On/Off Proc Day Billing
7622	7622	520 Reserve Capacity Prepaid
7624	7624	570 On/Off Proc Day Billing
7625	7728	570 Reserve Capacity Prepaid
7663	7663	570 1 GB Mem Activation
7680	7680	Accelerator for System i5
7681	7681	Accelerator for System i5
7682	7682	Accelerator for System i5
7687	7687	Accelerator for System i5
7738	7738	570 Base Proc Activation
7741	7741	550 Reserve Capacity Prepaid
7768	7768	CPU Power Regulator
7801	7801	6m HMC Attachment Cable
7802	7802	15m HMC Attachment Cable
7815	7815	595 One Processor Activation
7817	7817	SNI Fiber Adapter
7862	7862	Blind Swap Cassette (long)
7863	7863	Blind Swap Cassette (Double)
7864	7864	Blind Swap Cassette (DTXA)
7879	7879	Headless Enclosure
7884	7884	520 Rack Mount
7885	7885	520 Deskside
7886	7886	SF4 Rack Mount
7887	7887	SF4 Deskside
7897	7897	570 CUoD Proc Activation
7950	7950	570 1 GB CUoD Mem Activation
7951	7951	570 On/Off Proc Enablement
7952	7952	570 On/Off Proc Day Billing
7954	7954	570 On/Off Mem Enablement
7956	7956	570 Res Cap PrePaid
7957	7957	570 1 GB Mem Day Billing
7971	7971	595 On/Off Proc Enablement
7972	7972	595 On/Off Proc Day Billing

CCIN	Feat. code	Description
7975	7975	595 Reserve Capacity Prepaid
8093	8093	Optional Base 1.8 M I/O Rack
8094	8094	Optional Base 1.8 M I/O Rack
8133	8133	RJ45 to DB25 Interposer
8136	8136	Remote ASYNC Node (Rack)
8137	8137	Remote ASYNC Node
8244	8244	PCI WS Audio Adaptor
8312	8312	550 1.9 GHz Proc 0/2-way
8325	8325	520 1.9 GHz Processor
8327	8327	520 1.9 GHz Processor
8330	8330	520 1.9 GHz Processor 0/2-way
8338	8338	570 2.2 GHz Processor 0/2-way
8410	8410	520 Base Processor Activation
8413	8413	550 Base Processor Activation
8452	8452	570 One Processor Activation
8457	8457	595 Base Proc Activation
8470	8470	570 Base 1 GB Mem Activation
9004	9004	South Hemisphere Designator
9020	9020	V.35 Cable 20-ft
9021	9021	X.21 Cable 20-ft
9022	9022	EIA232 20-ft Cable
9023	9023	V.24 20-ft Enhanced Cable
9024	9024	Token-Ring Cable (2.44 m)
9025	9025	Ethernet Cable AUI (3 m)
9026	9026	EIA 232 6 m Client Acc cable
9027	9027	EIA 232 2.5 m Clint Acc cable
9079	8079	Optional Base 1.8 M I/O Rack
9079	9079	#9079 Base I/O Tower for 840 or SB3
9094	9094	Base PCI-X I/O Enclosure
9143	9143	Twinaxial Workstation Controller
9145	9145	Standard MFIOP/ASCII WSC
9149	9149	Twinaxial passthru adapter
9152	8152	Optional Base Twinaxial
9152	9152	Standard MFIOP/Twinaxial WSC
9153	9153	Standard MFIOP wo/Twinaxial WSC
9162	8162	Optional Base MFIOP w/Twinaxial
9162	9162	Standard MFIOP w/Twinaxial WSC
9163	9163	Standard MFIOP
9164	9164	Standard MFIOP
9174	7174	Ethernet IOA
9174	9174	Base Ethernet IOA
9175	7175	Token Ring IOA
9175	9175	Base Token Ring IOA
9206	1463	2m SPCN Cable
9211	9211	60m SPCN Optical cable
9212	0369	100m Optical SPCN Cable
9212	9212	100m SPCN Optical cable
9213	1465	15m SPCN Cable
9214	1466	30m SPCN Cable
9215	9215	60m SPCN Copper Cable
9219	1464	6m SPCN Cable
9243	9243	400W Availability Bulk
9299	9299	Base Enterprise Enablement
9301	9301	Upgraded 30-Disk Expansion
9570	9570	Reserved Rack Space
9739	9739	Base Optical Bus Adapter
9803	9803	2.5m DFCI cable
9814	9814	20-ft Antenna Cable Wireless

CCIN	Feat. code	Description
9815	9815	50-ft Antenna Cable Wireless
9820	9820	2nd Bus cable for Model 300
9835	9835	V.24 Cable 50-ft Enhanced
9836	9836	EIA232 Cable 50-ft
9838	9838	V.35 Cable 50-ft
9839	9839	X.21 Cable 50-ft
9853	9853	20.0m optical bus cable
9854	9854	60m optical bus cable
9865	9855	100.0 M optical bus cable
9876	9876	Base Optical Bus Adapter
9877	9877	Base HSL-2 Bus Adapter
9879	9879	20-ft/6m V.35 Cable
9880	9880	80-ft/24.4m V.35 Cable
9882	9882	20-ft/6m V.36 Cable
9883	9883	80-ft/24.4m V.36 Cable
9884	9884	150-ft/45.7m V.36 Cable
9885	9885	20-ft/6m X.21 Cable
9895	0366	Optical Bus Cable (20 m)
9927	9927	Channel Box and cable
9928	9928	1.7m attach cable
9929	9929	6.6m attach cable
9930	9930	24.0m attach cable
9980	9980	Serpentine Cable Connector
032A	0327	Operations Console Cable
032B	0328	Operations Console Cable
032C	0367	Operations Console PCI Cable
180A	7882	SCSI to IDE Converter Card
182A	1827	Serial-UPS Conversion Cable
185D	1857	2 Enclosure SP Flex Cable
185E	1858	3 Enclosure SP Flex Cable
185F	1859	4 Enclosure SP Flex Cable
206A	2061	720 (240 CPW) with #1500 Interactive
206B	2061	720 (240 CPW) with #1501 Interactive
206C	2061	720 (240 CPW) with #1502 Interactive
206D	2062	720 (480 CPW) with #1500 Interactive
206E	2062	720 (480 CPW) with #1501 Interactive
206F	2062	720 (480 CPW) with #1502 Interactive
207A	2062	720 (480 CPW) with #1503 Interactive
207B	2063	720 (810 CPW) with #1500 Interactive
207C	2063	720 (810 CPW) with #1502 Interactive
207D	2063	720 (810 CPW) with #1503 Interactive
207E	2063	720 (810 CPW) with #1504 Interactive
207F	2064	720 (1600 CPW) with #1500 Interactive
208A	2064	720 (1600 CPW) with #1502 Interactive
208B	2064	720 (1600 CPW) with #1503 Interactive
208C	2064	720 (1600 CPW) with #1504 Interactive
208D	2064	720 (1600 CPW) with #1505 Interactive
22A2	2248	270 (150 CPW) with #1517 Interactive
22A4	2250	270 (370 CPW) with #1516 Interactive
22A5	2250	270 (370 CPW) with #1518 Interactive
22A7	2252	270 (950 CPW) with #1516 Interactive
22A8	2252	270 (950CPW) with #1519 Interactive
22AA	2253	270 (2000 CPW) with #1516 Interactive
22AB	2253	270 (2000 CPW) with #1520 Interactive
23A1	2395	820 (370 CPW) with #1521 Interactive
23A2	2395	820 (370 CPW) with #1522 Interactive
23A3	2395	820 (370 CPW) with #1523 Interactive
23A4	2395	820 (370 CPW) with #1524 Interactive

CCIN	Feat. code	Description
23A9	2396	820 (950 CPW) with #1521 Interactive
23AA	2396	820 (950 CPW) with #1522 Interactive
23AB	2396	820 (950 CPW) with #1523 Interactive
23AC	2396	820 (950 CPW) with #1524 Interactive
23AD	2396	820 (950 CPW) with #1525 Interactive
23B1	2397	820 (2000 CPW) with #1521 Interactive
23B2	2397	820 (2000 CPW) with #1522 Interactive
23B3	2397	820 (2000 CPW) with #1523 Interactive
23B4	2397	820 (2000 CPW) with #1524 Interactive
23B5	2397	820 (2000 CPW) with #1525 Interactive
23B6	2397	820 (2000 CPW) with #1526 Interactive
23B8	2398	820 (3200 CPW) with #1521 Interactive
23B9	2398	820 (3200 CPW) with #1522 Interactive
23BA	2398	820 (3200 CPW) with #1523 Interactive
23BB	2398	820 (3200 CPW) with #1524 Interactive
23BC	2398	820 (3200 CPW) with #1525 Interactive
23BD	2398	820 (3200 CPW) with #1526 Interactive
23BE	2398	820 (3200 CPW) with #1527 Interactive
23C1	2400	830 (1850 CPW) with #1531 Interactive
23C2	2400	830 (1850 CPW) with #1532 Interactive
23C3	2400	830 (1850 CPW) with #1533 Interactive
23C4	2400	830 (1850 CPW) with #1534 Interactive
23C5	2400	830 (1850 CPW) with #1535 Interactive
23D1	2402	830 (4200 CPW) with #1531 Interactive
23D2	2402	830 (4200 CPW) with #1532 Interactive
23D3	2402	830 (4200 CPW) with #1533 Interactive
23D4	2402	830 (4200 CPW) with #1534 Interactive
23D5	2402	830 (4200 CPW) with #1535 Interactive
23D6	2402	830 (4200 CPW) with #1536 Interactive
23D8	2403	830 (7350 CPW) with #1531 Interactive
23D9	2403	830 (7350 CPW) with #1532 Interactive
23DA	2403	830 (7350 CPW) with #1533 Interactive
23DB	2403	830 (7350 CPW) with #1534 Interactive
23DC	2403	830 (7350 CPW) with #1535 Interactive
23DD	2403	830 (7350 CPW) with #1536 Interactive
23DE	2403	830 (7350 CPW) with #1537 Interactive
23E7	2431	Model 270 Processor with #1518
23E8	2418	840 (10000 CPW) with #1540 Interact.
23E9	2418	840 (10000 CPW) with #1541 Interact.
23EA	2418	840 (10000 CPW) with #1542 Interact.
23EB	2418	840 (10000 CPW) with #1543 Interact.
23EC	2418	840 (10000 CPW) with #1544 Interact.
23ED	2418	840 (10000 CPW) with #1545 Interact.
23EE	2418	840 (10000 CPW) with #1546 Interact.
23F0	2432	Model 270 Processor with #1516
23F1	2432	Model 270 Processor with #1519
23F4	2434	Model 270 Processor with #1516
23F5	2434	Model 270 Processor with #1520
23F8	2420	840 (16500 CPW) with #1540 Interact.
23F9	2420	840 (16500 CPW) with #1541 Interact.
23FA	2420	840 (16500 CPW) with #1542 Interact.
23FB	2420	840 (16500 CPW) with #1543 Interact.
23FC	2420	840 (16500 CPW) with #1544 Interact.
23FD	2420	840 (16500 CPW) with #1545 Interact.
23FE	2420	840 (16500 CPW) with #1546 Interact.
23FF	2420	840 (16500 CPW) with #1547 Interact.
241B	2069	Model 740 8-way Processor
241B	2070	Model 740 12-way Processor

CCIN	Feat. code	Description
241C	2067	Model 730 4-way Processor
241D	2068	Model 730 8-way Processor
241F	2065	Model 730 Processor
241F	2065	Model 730 Processor
242B	2064	Model 720 4-way Processor
242C	2062	Model 720 Processor
242D	2063	Model 720 2-way Processor
243A	2061	Model 720 Processor
245D	0153	Model 830 8-way Processor
246F	0158	Model 840 12-way Processor
246F	0159	Model 840 24-way Processor
249B	2435	Model 820 Processor with #1521
249C	2435	Model 820 Processor with #1522
249D	2435	Model 820 Processor with #1523
249E	2435	Model 820 Processor with #1524
24A8	2436	Model 820 Processor with #1521
24A9	2436	Model 820 Processor with #1522
24AA	2436	Model 820 Processor with #1523
24AB	2436	Model 820 Processor with #1524
24AC	2436	Model 820 Processor with #1525
24B0	2437	Model 820 Processor with #1521
24B1	2437	Model 820 Processor with #1522
24B2	2437	Model 820 Processor with #1523
24B3	2437	Model 820 Processor with #1524
24B4	2437	Model 820 Processor with #1525
24B5	2437	Model 820 Processor with #1526
24B8	2438	Model 820 Processor with #1521
24B9	2438	Model 820 Processor with #1522
24BA	2438	Model 820 Processor with #1523
24BB	2438	Model 820 Processor with #1524
24BC	2438	Model 820 Processor with #1525
24BD	2438	Model 820 Processor with #1526
24BE	2438	Model 820 Processor with #1527
24C0	2416	#1540 interactive 8/12-way 840 POD
24C1	2416	#1541 interactive 8/12-way 840 POD
24C2	2416	#1542 interactive 8/12-way 840 POD
24C3	2416	#1543 interactive 8/12-way 840 POD
24C4	2416	#1544 interactive 8/12-way 840 POD
24C5	2416	#1545 interactive 8/12-way 840 POD
24C6	2416	#1546 interactive 8/12-way 840 POD
24C8	2417	#1540 interactive 12/18-way 840 POD
24C9	2417	#1541 interactive 12/18-way 840 POD
24CA	2417	#1542 interactive 12/18-way 840 POD
24CB	2417	#1543 interactive 12/18-way 840 POD
24CC	2417	#1544 interactive 12/18-way 840 POD
24CD	2417	#1545 interactive 12/18-way 840 POD
24CE	2417	#1546 interactive 12/18-way 840 POD
24D0	2419	#1540 interactive 18/24-way 840 POD
24D1	2419	#1541 interactive 18/24-way 840 POD
24D2	2419	#1542 interactive 18/24-way 840 POD
24D3	2419	#1543 interactive 18/24-way 840 POD
24D4	2419	#1544 interactive 18/24-way 840 POD
24D5	2419	#1545 interactive 18/24-way 840 POD
24D6	2419	#1546 interactive 18/24-way 840 POD
24D7	2419	#1547 interactive 18/24-way 840 POD
24D8	2349	#1531 Interactive 4/8-way 830 CUoD
24D9	2349	#1532 Interactive 4/8-way 830 CUoD
24DA	2349	#1533 Interactive 4/8-way 830 CUoD

CCIN	Feat. code	Description
24DB	2349	#1534 Interactive 4/8-way 830 CUoD
24DC	2349	#1535 Interactive 4/8-way 830 CUoD
24DD	2349	#1536 Interactive 4/8-way 830 CUoD
24DE	2349	#1537 Interactive 4/8-way 830 CUoD
259A	2599	F95 Processor 2-way
25AE	8961	Model 570 0/2-way Processor
25AE	8971	Model 570 2/4-way Processor
25AE	8971	Model 570 4/8-way Processor
25AE	8971	Model 570 9/12-way Processor
25AE	8971	Model 570 13/16-way Processor
25B9	2463	Model 800 Processor
25BA	2432	Model 270 Processor
25BA	2452	Dedicated Domino Processor
25BA	2464	Model 800 Processor
25BA	2465	Model 810 Processor
25BA	2466	Model 810 Processor
25BC	0150	Model 820 Base Processor
25BD	0151	Model 820 Base Processor
25BE	0152	Model 820 Base Processor
25D3	0197	Model 890 24-way Processor
25D5	0198	Model 890 32-way Processor
25EB	2469	Model 810 2-way Processor
25F0	2467	Model 810 Processor
25F8	7878	Serial/VPD PCI Card
26A8	2351	Model 830 1/8-way POD with #1531
26A9	2351	Model 830 1/8-way POD with #1532
26AA	2351	Model 830 1/8-way POD with #1533
26AB	2351	Model 830 1/8-way POD with #1534
26AC	2351	Model 830 1/8-way POD with #1535
26AD	2351	Model 830 1/8-way POD with #1536
26AE	2351	Model 830 1/8-way POD with #1537
26B0	2352	Model 840 8/12-way POD with #1540
26B1	2352	Model 840 8/12-way POD with #1541
26B2	2352	Model 840 8/12-way POD with #1542
26B3	2352	Model 840 8/12-way POD with #1543
26B4	2352	Model 840 8/12-way POD with #1544
26B5	2352	Model 840 8/12-way POD with #1545
26B6	2352	Model 840 8/12-way POD with #1546
26B8	2353	Model 840 12/18-way POD with #1540
26B9	2353	Model 840 12/18-way POD with #1541
26BA	2353	Model 840 12/18-way POD with #1542
26BB	2353	Model 840 12/18-way POD with #1543
26BC	2353	Model 840 12/18-way POD with #1544
26BD	2353	Model 840 12/18-way POD with #1545
26BE	2353	Model 840 12/18-way POD with #1546
26BF	2353	Model 840 12/18-way POD with #1547
26C0	2354	Model 840 18/24-way POD with #1540
26C1	2354	Model 840 18/24-way POD with #1541
26C2	2354	Model 840 18/24-way POD with #1542
26C3	2354	Model 840 18/24-way POD with #1543
26C4	2354	Model 840 18/24-way POD with #1544
26C5	2354	Model 840 18/24-way POD with #1545
26C6	2354	Model 840 18/24-way POD with #1546
26C7	2354	Model 840 18/24-way POD with #1547
26C8	2354	Model 840 18/24-way POD with #1548
26D0	2461	Model 840 24-way Processor with #1540

CCIN	Feat. code	Description
26D1	2461	Model 840 24-way Processor with #1541
26D2	2461	Model 840 24-way Processor with #1542
26D4	2461	Model 840 24-way Processor with #1544
26D5	2461	Model 840 24-way Processor with #1545
26D6	2461	Model 840 24-way Processor with #1546
26D7	2461	Model 840 24-way Processor with #1547
26D8	2461	Model 840 24-way Processor with #1548
26EA	8961	Model 570 0/2-way Processor
26EA	8961	Model 570 2/4-way Processor
26F2	8971	Model 570 2/4-way Processor
26F2	8971	Model 570 4/8-way Processor
26F2	8971	Model 570 9/12-way Processor
26F2	8971	Model 570 13/16-way Processor
26F2	8971	570 CUoD 0/2way 1/65HZ Proc
273B	9730	Base HSL-2 Ports - 4 Copper
27AE	7865	L/ML CEC Backplane
27AF	7877	Model 520 Power Regulator
280E	5760	PCI-X Fibre Channel Disk Ctlr
280D	5761	PCI-X Fibre Channel Tape Ctlr
283F	7123	DASD Expansion Unit
283F	7127	DASD Expansion Unit
283F	7133	DASD Concurrent Maint Cage
284A		IOP Embedded
284B		IOP Embedded
284C		IOP Embedded
284D		IOP Embedded
284E		IOP Embedded
286C		IOP Embedded
286D		IOP Embedded
286F		IOP Embedded
287F		Model 825 Embedded 10/100 Ethernet
28B3	9787	Base HSL-2 Ports - 2 Copper
28BC	7124	DASD Expansion Unit - 5 slot
28CD	7136	DASD Expansion Unit - 6 slot
28CD	7137	DASD Concurrent Maintenance
28D2	6574	#6574 - 4-Disk Slot Exp - Base Ctlr
28D4	1846	Operator Panel - Model 570
28D7	7883	Model 520 SP Card
28D8	7818	HSL-2/RIO-G 2-Ports Copper
28D9	7867	L/ML Mid-backplane
28DA	7866	I/O PCI Backplane
28DB	7868	L/ML DASD Backplane
28DC	7869	Removable Media Backplane
28DD	7870	Power Supply Dist Backplane
28E7	6417	HSL-2/RIOG Bus Adapter
28E7	9517	Base HSL-2/RIOG Bus Adapter
28E8	7875	L/ML CPU Regulator
28EA	7881	Service Processor
28EB	7819	HSL/RIO 2-Ports Optical
28EF	0632	USB 2.0 PCI Adapter
28F6	6574	550 Base DASD Backplane
28F6	6592	#6592 - 4-Disk Slot Exp - Base Ctlr

CCIN	Feat. code	Description
28F7	6584	#6584 - 4-Disk Slot Exp - PCI-X Ctr
291E	7876	Model 520 Media Backplane Card
292C	4270	#4270 - Ctr to External Port Cable
292D	6594	#6594 - 4-Disk Slot Exp-PCI-X Ctr
292E	6593	#6593 - 4-Disk Slot Exp - PCI-X Ctr
292E	6594	#6594 - 4-Disk Slot Exp-PCI-X Ctr
2A6A	2065	560 CPW Model 730 Processor with #1506 Interactive Feature
2A6B	2065	560 CPW Model 730 Processor with #1507 Interactive Feature
2A6C	2065	560 CPW Model 730 Processor with #1508 Interactive Feature
2A6D	2065	560 CPW Model 730 Processor with #1509 Interactive Feature
2A6E	2066	1050 CPW Model 730 Processor with #1506 Interactive Feature
2A6F	2066	1050 CPW Model 730 Processor with #1507 Interactive Feature
2B6A	2066	1050 CPW Model 730 Processor with #1508 Interactive Feature
2B6B	2066	1050 CPW Model 730 Processor with #1509 Interactive Feature
2B6C	2066	1050 CPW Model 730 Processor with #1510 Interactive Feature
2B6D	2067	2000 CPW Model 730 Processor with #1506 Interactive Feature
2B6E	2067	2000 CPW Model 730 Processor with #1508 Interactive Feature
2B6F	2067	2000 CPW Model 730 Processor with #1509 Interactive Feature
2C6A	2067	2000 CPW Model 730 Processor with #1510 Interactive Feature
2C6B	2067	2000 CPW Model 730 Processor with #1511 Interactive Processor
2C6C	2068	2890 CPW Model 730 Processor with #1506 Interactive Feature
2C6D	2068	2890 CPW Model 730 Processor with #1508 Interactive Feature
2C6E	2068	2890 CPW Model 730 Processor with #1509 Interactive Feature
2C6F	2068	2890 CPW Model 730 Processor with #1510 Interactive Feature
2D6A	2068	2890 CPW Model 730 Processor with #1511 Interactive Processor
2D6B	2069	3660 CPW Model 740 Processor with #1514 Interactive Feature
2D6C	2069	3660 CPW Model 740 Processor with #1510 Interactive Feature
2D6D	2069	3660 CPW Model 740 Processor with #1511 Interactive Feature
2D6E	2069	3660 CPW Model 740 Processor with #1512 Interactive Feature
2E6A	2070	4550 CPW Model 740 Processor with #1514 Interactive Feature
2E6B	2070	4550 CPW Model 740 Processor with #1510 Interactive Feature
2E6C	2070	4550 CPW Model 740 Processor with #1511 Interactive Feature
2E6D	2070	_4550 CPW Model 740 Processor with #1512 Interactive Feature

CCIN	Feat. code	Description
2E6E	2070	4550 CPW Model 740 Processor with #1513 Interactive Feature
303E	7816	2/4 GB CUoD Main Storage
304E	7828	CUoD 8/16 GB (4X4 GB)
309B	4443	512 MB DDR
309B	4444	1 GB DDR DIMMs
309D	4452	2 GB Memory (4x512 MB DIMMs)
309E	4490	4 GB Memory (4x1 GB DIMMs)
309F	4453	4 GB Memory (4x1 GB DIMMs)
30AA	4454	8 GB Memory (4x2 GB DIMMs)
30AC	4450	16 GB DDR DIMMs
30B3	4491	16 GB Memory (4x4 GB DIMMs)
30D2	4447	2 GB DDR DIMMs
30D3	4445	4 GB DDR DIMMs
30D5	4449	8 GB DDR DIMMs
30DC	7814	4 GB Main Storage
30DE	7890	4/8 GB CUoD DDR1 Memory
30DF	7891	8/16 GB DDR-1 Main Storage
30F0	7892	512 MB Main Storage DDR2 DIMM
30F2	7893	4 GB Main Storage DDR2 DIMM
30F3	7894	8 GB Main Storage DDR2 DIMM
30F7	4492	32 GB Memory (4x8 GB DIMMs)
30F8	7935	16/32 GB DDR-1 Main Storage
312F	4497	16 GB DDR2 Main Storage
313A	4400	1 GB DDR2 Main Storage
313B	4474	2 GB DDR2 Main Storage
313D	4475	4 GB DDR2 Main Storage
313E	4477	8 GB DDR2 Main Storage
314C	4498	32 GB DDR2 Main Storage
314E	4496	8/16 GB DDR2 Main Storage
316F	4495	4/8 GB DDR2 Main Storage
515F	5138	Redundant Power and Cooling
51B6	5158	850 W Power Supply
522A	5230	Model 520 1-way Processor
522A	8950	Model 520 1-way Processor
522A	8951	Model 520 1-way Processor
522A	8952	Model 520 1-way Processor
522A	8953	Model 520 1-way Processor
522A	8972	Model 520 1-way Processor
528C	7813	0/8 GR 1.8 GHz CUoD MCM
528C	8966	595 1.9 Ghz Proc 0/16-way
528D	7154	Standard Edition for #0910
528D	7155	Enterprise Edition for #0910
528D	7551	HA Edition for #0910
528D	7629	Domino Edition for #0910
528D	7630	Solution Edition for #0910
528D	7631	Sol Ed-PeopleSoft EnterpriseOne
528D	7632	C2CRM Solution Ed w/Domino
528D	7640	2-way SAP Solution Edition
528D	7641	4-way SAP Solution Edition
528E	7747	Enterprise Edition for #0934
528E	7749	Enterprise Edition for #0936
528E	7757	Standard Edition for #0934
528E	7758	Standard Edition for #0935
528E	7759	Standard Edition for #0936
528E	7760	CBU Edition for #0937
528E	7763	HA Edition for #0934
528E	7764	HA Edition for #0935

CCIN	Feat. code	Description
528E	7765	HA Edition for #0936
528F	7140	520 Express Configuration
528F	7141	520 Express Configuration
528F	7142	520 Express Configuration
528F	7143	520 Express Configuration
528F	7144	520 Express Configuration
528F	7148	520 Express Configuration
528F	7152	520 Express Configuration
528F	7350	Value Edition for #0975
528F	7352	Value Edition for #0975
528F	7373	HA Edition for #0906
528F	7374	HA Edition for #0906
528F	7375	HA Edition for #0906
528F	7734	Enterprise Edition for #0906
528F	7735	Enterprise Edition for #0906
528F	7736	Enterprise Edition for #0906
528F	7784	Standard Edition for #0906
528F	7785	Standard Edition for #0906
52A4	8981	Model 595 Processor Book
571A	0647	PCI-X Disk/Tape Ctr w/o IOP
571A	5736	PCI-X Disk/Tape Ctr w/IOP
571A	5766	PCI-X Tape Controller
571A	5775	PCI-X Disk/Tape Ctr-w/o IOP
571B	0648	PCI-X Disk Ctr-90 MB w/o IOP
571B	5737	PCI-X Disk Ctr-90 MB w/IOP
571B	5776	PCI-X Disk Ctr-90 MB w/o IOP
573B	5713	PCI-X 1 Gbps iSCSI TOE-Copper
573C	5714	PCI-X 1 Gbps iSCSI
573D	5727	Integrated Cache - 40 MB
573D	5728	Integrated Cache - 40 MB
582E	7748	Enterprise Edition for #0935
63A0	4482	4 GB ¼-inch Cartridge Tape
63A0	4483	16 GB ¼-inch Cartridge Tape
63A0	4486	25 GB ¼-inch Cartridge Tape
63A0	4487	50 GB ¼-inch Cartridge Tape
63A0	4582	4 GB ¼-inch Cartridge Tape
63A0	4583	16 GB ¼-inch Cartridge Tape
63A0	4584	30 GB ¼-inch Cartridge Tape
63A0	4585	80 GB VXA-2 Tape Drive
63A0	4586	25 GB ¼-inch Cartridge Tape
63A0	4587	50 GB ¼-inch Cartridge Tape
63A0	4682	4 GB ¼-inch Cartridge Tape
63A0	4683	16 GB ¼-inch Cartridge Tape
63A0	4684	30 GB ¼-inch Cartridge Tape
63A0	4685	80 GB VXA-2 Tape Drive
63A0	4685	80 GB VXA-2 Tape Drive
63A0	4686	25 GB ¼-inch Cartridge Tape
63A0	4687	50 GB ¼-inch Cartridge Tape
63A0	5753	30 GB ¼-inch Cartridge Tape
63A0	5754	50 GB ¼-inch Cartridge Tape
63A0	6279	160 GB VXA-320 Tape Drive
63A0	6381	2.5 GB ¼-inch Cartridge Tape
63A0	6382	4 GB ¼-inch Cartridge Tape
63A0	6383	16 GB ¼-inch Cartridge Tape
63A0	6384	30 GB ¼-inch Cartridge Tape
63A0	6386	25 GB ¼-inch Cartridge Tape
63A0	6481	2.5 GB ¼-inch Cart Tape
63A0	6482	4 GB ¼-inch Cartridge Tape

CCIN	Feat. code	Description
63A0	6483	16 GB ¼-inch Cartridge Tape
63A0	6484	30 GB ¼-inch Cartridge Tape
63A0	6486	25 GB ¼-inch Cartridge Tape
63A0	8287	Optional Base 50 GB QIC Tape
63A0	9284	Base 30 GB 1/4-Inch Cart Tape
63A0	9285	Base 80 GB VXA-2 Tape Drive
63A0	9653	Base 30 GB ¼-inch Tape
788A	7880	Model 570 Base Enclosure
917A	9171	Standard MFIOF/ASCII WSC
917C	9173	Standard MFIOF/LocalTalk WSC
918D	9177	Ethernet MFIOF
918E	9176	Base MFIOF
n/a	0641	ESCON® Controller Unit
n/a	0836	#4328 Load Source Specify
n/a	0860	iSeries Server 2463
n/a	0861	iSeries Server 2463
n/a	0862	iSeries Server 2464
n/a	0868	iSeries Server 2465
n/a	0889	iSeries Server 2489
n/a	0900	Solution Package for 8950
n/a	0901	Solution Package for 8951
n/a	0902	Solution Package for 8952
n/a	0903	Solution Package for 8953
n/a	0904	Solution Package for 8954
n/a	0905	Solution Package for 8955
n/a	0906	1-way Server Feat 520 1x8327/30
n/a	0910	1/4-way Serv Feat 550 2x8312
n/a	0914	Solution Package for 8958
n/a	0915	Solution Package for 8958
n/a	0919	Solution package for 8961
n/a	0920	Solution Package for 8961
n/a	0921	Solution Package for 8971
n/a	0922	Solution Package for 8971
n/a	0923	Solution Package for 8962
n/a	0924	Solution Package for 8971
n/a	0926	Solution Package for 8971
n/a	0928	Capacity Backup for 8971
n/a	0930	Solution Package for 8971
n/a	0934	2/4-way Server Feat 570 2x8338
n/a	0935	4/8-way Server Feat 570 4x8338
n/a	0936	8/16-way Server Feat 570 8x8338
n/a	0937	2/16-way Server Feat 570 8x8338
n/a	0940	8/16-way Server Feat 595 1x8966
n/a	0941	16/32-way Server Feat 595 2x8966
n/a	0943	32/64-way Server Feat 595 4x8966
n/a	0944	4/32-way Server Feat 595 2x8966
n/a	0970	1-way Server Feat 520 1x8325/27
n/a	0975	1-way Server Feat 520 1x8325/27
n/a	1614	870 POD Activation
n/a	1682	On/Off Prepaid for Model 825
n/a	1683	On/Off Prepaid for Model 825
n/a	1684	On/Off Prepaid for Model 870
n/a	1685	On/Off Prepaid for Model 870
n/a	1686	On/Off Prepaid for Model 870
n/a	1688	On/Off Prepaid for Model 890
n/a	1689	On/Off Prepaid for Model 890
n/a	1691	On/Off Prepaid for Model 890
n/a	1692	On/Off Prepaid for Model 890

CCIN	Feat. code	Description
n/a	1695	On/Off Prepaid for Model 870
n/a	1774	TCoD Enablement for Model 870
n/a	1784	TCoD Billing for Model 870
n/a	5550	Sys Console on HMC
n/a	5553	Sys Console-Ethernet w/o IOP
n/a	5554	Mirror 35 GB Disk/Ctrl Package
n/a	5555	Mirror 70 GB Disk/Ctrl Package
n/a	5556	Mirror 141.12 GB Disk/Ctrl Package
n/a	5557	Sys Console-Ethernet w/o IOP
n/a	5560	Mirror 35 GB Drawer Package
n/a	5561	Mirror 70 GB Drawer Package
n/a	5562	Mirror 35 GB Tower Package
n/a	5563	Mirror 70 GB Tower Package
n/a	5564	Mirror 141.12 GB Drawer Package
	5740	1 Gbps BaseT Ethernet (4-Port)
	5740	1 Gbps BaseT Ethernet (4-Port)
	9548	Base 1 GB Main Storage
	9548	Base 1 GB Main Storage
	9549	Base 2 GB Main Storage
	9549	Base 2 GB Main Storage
	9553	Base 4 GB Main Storage

Archived

Feature code cross reference

This list contains the feature code, Customer Card Identification Number (CCIN), and description for many System i5 family system features. It assists clients and IBM personnel in configuring Miscellaneous Equipment Specifications (MES) and upgrades. It provides a cross reference for the feature code used for ordering with a CCIN number reported by the Hardware Resources Listing.

The listing in this chapter is sorted by feature code. The feature code is used by marketing to report configurations and work with upgrades. The entries selected are those that are most useful when interpreting Hardware Resource Listings.

Refer to Chapter 8, “Customer Card Identification Numbers cross reference” on page 303, for a listing of the features sorted by CCIN number. The CCIN number is used when working from a Hardware Resource Listing. The Hardware Resource listing is also known as the *Rack Configuration Listing*.

Feat. code	CCIN	Description
0047	0047	Device Parity RAID-6 All
0121	0121	#0121 Lower Unit in Rack Specify
0122	0122	#0122 Upper Unit in Rack Specify
0135	0135	Rear Cover - CEC only
0136	0136	Rear Cover - CEC with #7116
0145	0145	AIX Partition Specify
0150	0150	820 Base Processor
0150	25BC	Model 820 Base Processor
0151	0151	820 Base Processor
0151	25BD	Model 820 Base Processor
0152	0152	820 Base Processor
0152	25BE	Model 820 Base Processor
0153	245D	Model 830 8-way Processor
0158	246F	Model 840 12-way Processor
0159	246F	Model 840 24-way Processor
0165	0165	VHDCI Attachment
0197	25D3	Model 890 24-way Processor
0198	25D5	Model 890 32-way Processor
0226	0226	1 Gbps Ethernet Specify
0272	0272	Renovated by IBM
0290	0290	Ext Tape Attached via #5736,#5775
0297	2295	Model 250 Package
0297	0297	Model 250 Package - 2295
0298	2296	Model 250 Package
0298	0298	Model 250 Package - 2296
0299	0299	MES Conv. Analysis for #5580, #5581
0327	032A	Operations Console Cable
0328	032B	Operations Console Cable
0329	0329	V.24/EIA232 80-ft Cable
0330	0330	V.24/EIA232 20-ft Cable
0331	0331	V.24/EIA232 50-ft Cable
0332	0332	V.24/EIA232 20-ft Enh Cable
0333	0333	V.24/EIA232 50-ft Enh Cable
0334	0334	V.24/EIA232 80-ft Enh Cable
0335	0335	V.36/EIA449 20-ft Cable
0336	0336	V.36/EIA449 50-ft Cable
0337	0337	V.36/EIA449 150-ft Cable
0338	0338	V.35 20-ft Cable
0339	0339	V.35 50-ft Cable
0340	0340	V.35 80-ft Cable
0341	0341	X.21 20-ft Cable
0342	0342	X.21 50-ft Cable
0344	0344	20-ft Comm Console Cable
0348	0348	V.24/EIA232 20-ft PCI Cable
0349	0349	V.24/EIA232 50-ft PCI Cable
0350	0350	V.24/EIA232 20-ft E PCI Cable
0351	0351	V.24/EIA232 50-ft E PCI Cable
0352	0352	V.24/EIA232 80-ft E PCI Cable
0353	0353	V.35 20-ft PCI Cable
0354	0354	V.35 50-ft PCI Cable
0355	0355	V.35 80-ft PCI Cable
0356	0356	V.36 20-ft PCI Cable
0357	0357	V.36 50-ft PCI Cable
0358	0358	V.36 150-ft PCI Cable
0359	0359	X.21 20-ft PCI Cable
0360	0360	X.21 50-ft PCI Cable
0362	0362	Comm Console PCI Cable
0364	0364	Parallel Cable

Feat. code	CCIN	Description
0365	0365	V.24/EIA232 80-ft PCI Cable
0366	9895	Optical Bus Cable (20 m)
0367	032C	Operations Console PCI Cable
0369	9212	100m Optical SPCN Cable
0380	0380	Remote Control Panel Cable
0381	0381	Remote Control Panel Cable
0382	0382	Remote Control Panel Cable
0383	0383	Remote Control Panel Cable
0398	2745	Operations Console Package
0426	0446	512 MB Server Memory
0427	0447	1 GB Server Memory
0428	0448	2 GB Server Memory
0446	0446	512 MB DDR Server Memory
0447	0447	1 GB DDR Server Memory
0448	0448	2 GB DDR Server Memory
0530	0530	Software Version V5R3
0531	0531	#0531 i5/OS V5R3, V5R3M5 LIC
0532	0532	V5R4 OS, V5R4M0 LIC
0550	0550	#0550 iSeries Rack - 830 Rack
0551	0551	#0551 iSeries Rack - 270 Rack
0553	0553	#0553 iSeries 2.0m Rack
0565	5066	#5065 Equivalent
0574	5079	#5074 Equivalent
0578	5078	PCI Expansion Unit in Rack
0588	5088	PCI-X Expansion Unit in Rack
0595	5095	PCI-X Tower Unit in Rack
0599	0599	Rack filler kit
0601	2743	Linux Direct Attach-2743
0602	2760	Linux Direct Attach-2760
0603	2744	Linux Direct Attach-2744
0604	2763	Linux Direct Attach-2763
0605	2748	Linux Direct Attach-4748
0606	2778	Linux Direct Attach-4778
0607	2838	Linux Direct Attach-4838
0608	2745	Linux Direct Attach-4745
0609	2772	Linux Direct Attach-2772
0610	2772	Linux Direct Attach-2773
0611	2765	Direct Attach 2765
0612	2766	Linux Direct Attach-2766
0613	2742	Linux Direct Attach-2742
0614	2793	Linux Direct Attach-2793
0615	2793	Linux Direct Attach-2794
0616	2805	Linux Direct Attach-2805
0617	2805	Linux Direct Attach-2806
0618	2757	Linux Direct Attach-2757
0619	2782	Linux Direct Attach-2782
0620	5700	Linux Direct Attach-5700
0621	5701	Linux Direct Attach-5701
0623	2849	Linux Direct Attach-2849
0624	5702	Linux Direct Attach-5702
0625	5704	Linux Direct Attach-5704
0626	2787	Linux Direct Attach-2787
0627	2780	Linux Direct Attach-2780
0628	5703	Linux Direct Attach-5703
0632	28EF	USB 2.0 PCI Adapter
0633	2849	LANA1+ (GXT 135P)
0634	2944	128-port ASYNC Adapter
0635	2962	SDLC/X.25 - 2-port Adapter

Feat. code	CCIN	Description
0636	2842	Graphics Adapter (GXT4500P)
0637	4961	100/10 Mbps 4-port Ethernet Adapter
0638	6230	SSA (40 MBps) Adapter
0639	6231	128 MB DIMM & CD-ROM
0640	6235	Fast Write Cache Option
0641	n/a	ESCON Controller Unit
0642	2498	PCI Ultra-3 RAID Adapter
0643	5706	Linux Direct Attach-5706
0644	5707	Linux Direct Attach-5707
0645	5702	Direct Attach 5712
0646	5716	Direct Attach 5716
0647	571A	PCI-X Disk/Tape Ctr w/o IOP
0648	571B	PCI-X Disk Ctr-90 MB w/o IOP
0694	5094	#5094 Equivalent
0836	n/a	#4328 Load Source Specify
0860	n/a	iSeries Server 2463
0861	n/a	iSeries Server 2463
0862	n/a	iSeries Server 2464
0868	n/a	iSeries Server 2465
0889	n/a	iSeries Server 2489
0900	n/a	Solution Package for 8950
0901	n/a	Solution Package for 8951
0902	n/a	Solution Package for 8952
0903	n/a	Solution Package for 8953
0904	n/a	Solution Package for 8954
0905	n/a	Solution Package for 8955
0906	n/a	1-way Server Feat 520 1x8327/30
0910	n/a	1/4-way Server Feat 550 2x8312
0914	n/a	Solution Package for 8958
0915	n/a	Solution Package for 8958
0919	n/a	Solution package for 8961
0920	n/a	Solution Package for 8961
0921	n/a	Solution Package for 8971
0922	n/a	Solution Package for 8971
0923	n/a	Solution Package for 8962
0924	n/a	Solution Package for 8971
0926	n/a	Solution Package for 8971
0928	n/a	Capacity Backup for 8971
0930	n/a	Solution Package for 8971
0934	n/a	2/4-way Server Feat 570 2x8338
0935	n/a	4/8-way Server Feat 570 4x8338
0936	n/a	8/16-way Server Feat 570 8x8338
0937	n/a	2/16-way Server Feat 570 8x8338
0940	n/a	8/16-way Server Feat 595 1x8966
0941	n/a	16/32-way Server Feat 595 2x8966
0943	n/a	32/64-way Server Feat 595 4x8966
0944	n/a	4/32-way Server Feat 595 2x8966
0970	n/a	1-way Server Feat 520 1x8325/27
0975	n/a	1-way Server Feat 520 1x8325/27
1105	6105	Single Disk Unit (320 MB) Kit
1107	6107	Single Disk Unit (400 MB) Kit
1109	6109	Single Disk Unit (988 MB) Kit
1200	6105	Single Disk Unit (320 MB) Kit
1201	6107	Single Disk Unit (400 MB) Kit
1202	6109	Single Disk Unit (988 MB) Kit
1203	6602	Single Disk Unit (1031 MB) Kit
1204	6603	Single Disk Unit (1967 MB) Kit
1205	6605	Additional 1.031 GB Disk Unit

Feat. code	CCIN	Description
1206	6606	Additional 1.967 GB Disk Unit
1207	6607	Additional 4.194 GB Disk Unit
1210	6109	Additional Disk Unit (988 MB)
1211	6602	Additional Disk Unit (1.031 GB)
1212	6603	Additional Disk Unit (1967 MB)
1213	6602	Standard Disk Unit (1.031 GB, 2 byte)
1214	6603	Optional Base Disk Unit (1.967 GB, 2b)
1250	6378	525 MB ¼-inch Tape Kit
1251	6379	1.2 GB ¼-inch Tape Kit
1252	6380	2.5 GB ¼-inch Tape Kit
1260	6380	2.5 GB ¼-inch Tape
1261	6390	7.0 GB 8 mm Cart Tape
1262	6335	840 MB QIC-3040-MC
1307	1307	1.75m HSL-2 Cable
1308	1308	2.5m HSL-2Cable
1312	6602	1-byte 1.03 GB Disk Unit Kit
1313	6603	1-byte 1.96 GB Disk Unit Kit
1322	6602	2-byte 1.03 GB Disk Unit Kit
1323	6603	2-byte 1.96 GB Disk Unit Kit
1325	6605	2-byte 1.03 GB Disk Unit Kit
1326	6606	2-byte 1.96 GB Disk Unit Kit
1327	6607	2-byte 4.19 GB Disk Unit Kit
1333	6713	2-byte 8.58 GB Disk Unit Kit
1334	6714	2-byte 17.54 GB Disk Unit Kit
1335	6335	6335 External Conversion Kit
1336	6606	2-byte 1.96 GB Disk Unit Kit
1337	6607	2-byte 4.19 GB Disk Unit Kit
1349	6379	1.2 GB ¼-inch Tape Kit
1350	6380	2.5 GB ¼-inch Tape Kit
1355	6385	13.0 GB ¼-inch Tape Kit
1360	6390	7.0 GB 8 mm Cartridge Tape Kit
1378	6378	525 MB ¼-inch Cart Tape Kit
1379	6379	1.2 GB ¼-inch Cart Tape Kit
1380	6380	2.5 GB ¼-inch Cart Tape Kit
1460	0343	3m Copper HSL Cable
1461	0361	6m Copper HSL Cable
1462	0368	15 m Copper HSL Cable
1463	9206	2 m SPCN Cable
1464	9219	6 m SPCN Cable
1465	9213	15 m SPCN Cable
1466	9214	30 m SPCN Cable
1468	1469	4.3m/200V/25A HD Wired EMEA
1468	1468	250 m Optical SPCN Cable
1470	1470	6 m HSL Optical Cable
1471	1471	30 m HSL Optical Cable
1472	1472	100 m HSL Optical Cable
1473	1473	250 m HSL Optical Cable
1474	1474	6 m HSL to HSL-2 Cable
1475	1475	10 m HSL to HSL-2 Cable
1477	1477	200V 16A 14 Ft PDU Cord
1481	1481	1.2 m HSL-2 Cable
1482	1482	3.5 m HSL-2 Cable
1483	1483	10 m HSL-2 Cable
1485	1485	15 m HSL-2 Cable
1500	1500	Interactive Capacity Card
1501	1501	Interactive Capacity Card
1502	1502	Interactive Capacity Card
1503	1503	Interactive Capacity Card

Feat. code	CCIN	Description
1504	1504	Interactive Capacity Card
1505	1505	Interactive Capacity Card
1506	1506	Interactive Capacity Card
1507	1507	Interactive Capacity Card
1508	1508	Interactive Capacity Card
1509	1509	Interactive Capacity Card
1510	1510	Interactive Capacity Card
1511	1511	Interactive Capacity Card
1512	1512	Interactive Capacity Card
1513	1513	Interactive Capacity Card
1514	1514	Interactive Capacity Card
1516	1516	Interactive Capacity Card
1517	1517	Interactive Capacity Card
1518	1518	Interactive Capacity Card
1519	1519	Interactive Capacity Card
1520	1520	Interactive Capacity Card
1521	1521	Interactive Capacity Card
1522	1522	Interactive Capacity Card
1523	1523	Interactive Capacity Card
1524	1524	Interactive Capacity Card
1525	1525	Interactive Capacity Card
1526	1526	Interactive Capacity Card
1527	1527	Interactive Capacity Card
1531	1531	Interactive Capacity Card
1532	1532	Interactive Capacity Card
1533	1533	Interactive Capacity Card
1534	1534	Interactive Capacity Card
1535	1535	Interactive Capacity Card
1536	1536	Interactive Capacity Card
1537	1537	Interactive Capacity Card
1540	1540	Interactive Capacity Card
1541	1541	Interactive Capacity Card
1542	1542	Interactive Capacity Card
1543	1543	Interactive Capacity Card
1544	1544	Interactive Capacity Card
1545	1545	Interactive Capacity Card
1546	1546	Interactive Capacity Card
1547	1547	Interactive Capacity Card
1548	1548	Interactive Capacity Card
1576	1576	Interactive Capacity Card
1577	1577	Interactive Capacity Card
1578	1578	Interactive Capacity Card
1579	1579	Interactive Capacity Card
1581	1581	Interactive Capacity Card
1583	1583	Interactive Capacity Card
1585	1585	Interactive Capacity Card
1587	1587	Interactive Capacity Card
1588	1588	Interactive Capacity Card
1591	1591	Interactive Capacity Card
1602	6602	Single Disk Unit Kit (1.03 GB)
1603	6603	Single Disk Unit Kit (1.96 GB)
1614	n/a	870 POD Activation
1682	n/a	On/Off Prepaid for Model 825
1683	n/a	On/Off Prepaid for Model 825
1684	n/a	On/Off Prepaid for Model 870
1685	n/a	On/Off Prepaid for Model 870
1686	n/a	On/Off Prepaid for Model 870
1688	n/a	On/Off Prepaid for Model 890

Feat. code	CCIN	Description
1689	n/a	On/Off Prepaid for Model 890
1691	n/a	On/Off Prepaid for Model 890
1692	n/a	On/Off Prepaid for Model 890
1695	n/a	On/Off Prepaid for Model 870
1774	n/a	TCoD Enablement for Model 870
1784	n/a	TCoD Billing for Model 870
1800	1800	HSL-2 Ports - 2 Copper
1801	1801	HSL-2 Ports - 2 Optical
1802	1802	IBT 2 port
1806	1806	HSL-2 Ports - 2 Copper
1807	1807	HSL-2 Ports - 2 Optical
1827	182A	Serial-UPS Conversion Cable
1846	28D4	Operator Panel - Model 570
1850	2118	VHDCI to P Converter Cable
1851	2424	0.6m SCSI P-P Cable
1852	2425	2.5m SCSI P-P Cable
1855	2861	4-port EIA 232 Cable
1857	185D	2 Enclosure SP Flex Cable
1858	185E	3 Enclosure SP Flex Cable
1859	185F	4 Enclosure SP Flex Cable
1873	3124	Dwr to Dwr Serial Cable
1874	3125	Rack to Rack Serial Cable
1875	3925	Serial Port Converter Cable
1876	3636	L200 Flat Panel Monitor
1889	6120	80 GB VXA-2 Tape Drive
1893	3273	36.4 GB 10k rpm Disk Unit
1894	3274	73.4 GB 10k rpm Disk Unit
1895	3275	146.8 GB 10k rpm Disk Unit
1896	3277	36.4 GB 15k rpm Disk Unit
1897	3278	73.4 GB 15k rpm Disk Unit
1898	3279	146.8 GB Disk Unit
2010	2010	1.6 SPPR CPU for Model 20S
2030	2030	0.7 SPPR CPU for Model 200
2031	2031	1.1 SPPR CPU for Model 200
2032	2032	1.6 SPPR CPU for Model 200
2040	2040	1.1 SPPR Processor
2041	2041	1.6 SPPR Processor
2042	2042	2.0 SPPR Processor
2043	2043	3.0 SPPR Processor
2044	2044	5.0 SPPR Processor
2050	2050	6.4 SPPR Processor
2051	2051	11.4 SPPR Processor
2052	2052	16.8 SPPR Processor
2061	206C	720 (240 CPW) with #1502 Interactive
2061	206B	720 (240 CPW) with #1501 Interactive
2061	243A	Model 720 Processor
2061	206A	720 (240 CPW) with #1500 Interactive
2062	242C	Model 720 Processor
2062	206D	720 (480 CPW) with #1500 Interactive
2062	206E	720 (480 CPW) with #1501 Interactive
2062	206F	720 (480 CPW) with #1502 Interactive
2062	207A	720 (480 CPW) with #1503 Interactive
2063	207B	720 (810 CPW) with #1500 Interactive
2063	207C	720 (810 CPW) with #1502 Interactive
2063	242D	Model 720 2-way Processor
2063	207D	720 (810 CPW) with #1503 Interactive
2063	207E	720 (810 CPW) with #1504 Interactive
2064	208B	720 (1600 CPW) with #1503 Interactive

Feat. code	CCIN	Description
2064	208A	720 (1600 CPW) with #1502 Interactive
2064	207F	720 (1600 CPW) with #1500 Interactive
2064	208C	720 (1600 CPW) with #1504 Interactive
2064	208D	720 (1600 CPW) with #1505 Interactive
2064	242B	Model 720 4-way Processor
2065	241F	Model 730 Processor
2065	241F	Model 730 Processor
2065	2A6C	560 CPW Model 730 Processor with #1508 Interactive Feature
2065	2A6D	560 CPW Model 730 Processor with #1509 Interactive Feature
2065	2A6A	560 CPW Model 730 Processor with #1506 Interactive Feature
2065	2A6B	560 CPW Model 730 Processor with #1507 Interactive Feature
2066	2066	Model 730 2-way Processor
2066	2B6A	1050 CPW Model 730 Processor with #1508 Interactive Feature
2066	2A6F	1050 CPW Model 730 Processor with #1507 Interactive Feature
2066	2A6E	1050 CPW Model 730 Processor with #1506 Interactive Feature
2066	2B6B	1050 CPW Model 730 Processor with #1509 Interactive Feature
2066	2B6C	1050 CPW Model 730 Processor with #1510 Interactive Feature
2067	241C	Model 730 4-way Processor
2067	2C6A	2000 CPW Model 730 Processor with #1510 Interactive Feature
2067	2B6D	2000 CPW Model 730 Processor with #1506 Interactive Feature
2067	2C6B	2000 CPW Model 730 Processor with #1511 Interactive Processor
2067	2B6E	2000 CPW Model 730 Processor with #1508 Interactive Feature
2067	2B6F	2000 CPW Model 730 Processor with #1509 Interactive Feature
2068	2D6A	2890 CPW Model 730 Processor with #1511 Interactive Processor
2068	2C6F	2890 CPW Model 730 Processor with #1510 Interactive Feature
2068	2C6C	2890 CPW Model 730 Processor with #1506 Interactive Feature
2068	2C6E	2890 CPW Model 730 Processor with #1509 Interactive Feature
2068	241D	Model 730 8-way Processor
2068	2C6D	2890 CPW Model 730 Processor with #1508 Interactive Feature
2069	2D6B	3660 CPW Model 740 Processor with #1514 Interactive Feature
2069	2D6D	3660 CPW Model 740 Processor with #1511 Interactive Feature
2069	2D6E	3660 CPW Model 740 Processor with #1512 Interactive Feature
2069	241B	Model 740 8-way Processor
2069	2D6C	3660 CPW Model 740 Processor with #1510 Interactive Feature
2070	2E6B	4550 CPW Model 740 Processor with #1510 Interactive Feature

Feat. code	CCIN	Description
2070	2E6A	4550 CPW Model 740 Processor with #1514 Interactive Feature
2070	2E6C	4550 CPW Model 740 Processor with #1511 Interactive Feature
2070	2E6D	_4550 CPW Model 740 Processor with #1512 Interactive Feature
2070	2E6E	4550 CPW Model 740 Processor with #1513 Interactive Feature
2070	241B	Model 740 12-way Processor
2114	2114	External SCSI Y-Cable
2159	2159	Model 170 Processor
2160	2160	Model 170 Processor
2164	2164	Model 170 Processor
2176	2176	Model 170 Processor
2183	2183	Model 170 Processor
2207	2207	Model S40 8-way Processor
2208	2208	Model S40 12-way Processor
2248	22A2	270 (150 CPW) with #1517 Interactive
2248	2248	Model 270 Processor
2250	22A5	270 (370 CPW) with #1518 Interactive
2250	22A4	270 (370 CPW) with #1516 Interactive
2250	2250	Model 270 Processor
2252	2252	Model 270 Processor
2252	22A8	270 (950CPW) with #1519 Interactive
2252	22A7	270 (950 CPW) with #1516 Interactive
2253	2253	Model 270 2-way Processor
2253	22AB	270 (2000 CPW) with #1520 Interactive
2253	22AA	270 (2000 CPW) with #1516 Interactive
2289	2289	Model 170 Processor
2290	2290	Model 170 Processor
2291	2291	Model 170 Processor
2292	2292	Model 170 Processor
2295	2295	Model 250 Processor
2296	2296	Model 250 Processor
2298	2290	Model 170 Processor Package 64 MB
2299	2291	Model 170 Processor Package 64 MB
2315	2315	Model SB2 8-way Processor
2316	2316	Model SB3 12-way Processor
2318	2318	Model SB3 24-way Processor
2341	2341	Model S40 ISV 12-w Processor
2349	24D8	#1531 Interactive 4/8-way 830 CUoD
2349	24D9	#1532 Interactive 4/8-way 830 CUoD
2349	24DA	#1533 Interactive 4/8-way 830 CUoD
2349	24DB	#1534 Interactive 4/8-way 830 CUoD
2349	24DC	#1535 Interactive 4/8-way 830 CUoD
2349	24DD	#1536 Interactive 4/8-way 830 CUoD
2349	24DE	#1537 Interactive 4/8-way 830 CUoD
2351	26AD	Model 830 1/8-way POD with #1536
2351	2351	Model 830 1/8-way POD
2351	26AE	Model 830 1/8-way POD with #1537
2351	26AC	Model 830 1/8-way POD with #1535
2351	26AA	Model 830 1/8-way POD with #1533
2351	26A9	Model 830 1/8-way POD with #1532
2351	26A8	Model 830 1/8-way POD with #1531
2351	26AB	Model 830 1/8-way POD with #1534
2352	26B4	Model 840 8/12-way POD with #1544
2352	26B2	Model 840 8/12-way POD with #1542
2352	26B3	Model 840 8/12-way POD with #1543
2352	26B6	Model 840 8/12-way POD with #1546

Feat. code	CCIN	Description
2352	26B1	Model 840 8/12-way POD with #1541
2352	26B0	Model 840 8/12-way POD with #1540
2352	26B5	Model 840 8/12-way POD with #1545
2352	2352	Model 840 8/12-way POD
2353	26BA	Model 840 12/18-way POD with #1542
2353	26BB	Model 840 12/18-way POD with #1543
2353	26B9	Model 840 12/18-way POD with #1541
2353	26B8	Model 840 12/18-way POD with #1540
2353	26BD	Model 840 12/18-way POD with #1545
2353	26BE	Model 840 12/18-way POD with #1546
2353	26BF	Model 840 12/18-way POD with #1547
2353	26BC	Model 840 12/18-way POD with #1544
2353	2353	Model 840 12/18-way POD
2354	26C5	Model 840 18/24-way POD with #1545
2354	26C8	Model 840 18/24-way POD with #1548
2354	2354	Model 840 18/24-way POD
2354	26C6	Model 840 18/24-way POD with #1546
2354	26C7	Model 840 18/24-way POD with #1547
2354	26C2	Model 840 18/24-way POD with #1542
2354	26C0	Model 840 18/24-way POD with #1540
2354	26C1	Model 840 18/24-way POD with #1541
2354	26C4	Model 840 18/24-way POD with #1544
2354	26C3	Model 840 18/24-way POD with #1543
2383	2383	Model 170 Processor
2384	2384	Model 170 Processor
2385	2385	Model 170 Processor
2386	2386	Model 170 Processor
2388	2388	Model 170 2-way Processor
2395	23A1	820 (370 CPW) with #1521 Interactive
2395	2395	Model 820 Processor
2395	23A4	820 (370 CPW) with #1524 Interactive
2395	23A2	820 (370 CPW) with #1522 Interactive
2395	23A3	820 (370 CPW) with #1523 Interactive
2396	23A9	820 (950 CPW) with #1521 Interactive
2396	2396	Model 820 Processor
2396	23AA	820 (950 CPW) with #1522 Interactive
2396	23AB	820 (950 CPW) with #1523 Interactive
2396	23AC	820 (950 CPW) with #1524 Interactive
2396	23AD	820 (950 CPW) with #1525 Interactive
2397	23B6	820 (2000 CPW) with #1526 Interactive
2397	2397	Model 820 2-way Processor
2397	23B3	820 (2000 CPW) with #1523 Interactive
2397	23B4	820 (2000 CPW) with #1524 Interactive
2397	23B5	820 (2000 CPW) with #1525 Interactive
2397	23B2	820 (2000 CPW) with #1522 Interactive
2397	23B1	820 (2000 CPW) with #1521 Interactive
2398	23B8	820 (3200 CPW) with #1521 Interactive
2398	23B9	820 (3200 CPW) with #1522 Interactive
2398	23BB	820 (3200 CPW) with #1524 Interactive
2398	23BC	820 (3200 CPW) with #1525 Interactive
2398	23BD	820 (3200 CPW) with #1526 Interactive
2398	23BA	820 (3200 CPW) with #1523 Interactive
2398	23BE	820 (3200 CPW) with #1527 Interactive
2398	2398	Model 820 4-way Processor
2400	23C5	830 (1850 CPW) with #1535 Interactive
2400	2400	Model 830 2-way Processor
2400	23C1	830 (1850 CPW) with #1531 Interactive
2400	23C2	830 (1850 CPW) with #1532 Interactive

Feat. code	CCIN	Description
2400	23C3	830 (1850 CPW) with #1533 Interactive
2400	23C4	830 (1850 CPW) with #1534 Interactive
2402	23D1	830 (4200 CPW) with #1531 Interactive
2402	23D3	830 (4200 CPW) with #1533 Interactive
2402	23D6	830 (4200 CPW) with #1536 Interactive
2402	23D5	830 (4200 CPW) with #1535 Interactive
2402	23D2	830 (4200 CPW) with #1532 Interactive
2402	2402	Model 830 4-way Processor
2402	23D4	830 (4200 CPW) with #1534 Interactive
2403	23DD	830 (7350 CPW) with #1536 Interactive
2403	23D8	830 (7350 CPW) with #1531 Interactive
2403	23DA	830 (7350 CPW) with #1533 Interactive
2403	23D9	830 (7350 CPW) with #1532 Interactive
2403	23DB	830 (7350 CPW) with #1534 Interactive
2403	2403	Model 830 8-way Processor
2403	23DE	830 (7350 CPW) with #1537 Interactive
2403	23DC	830 (7350 CPW) with #1535 Interactive
2407	2407	Dedicated Domino Processor
2408	2408	Dedicated Domino Processor
2409	2409	Dedicated Domino Processor (2-way)
2410	2410	100 Client Server Processor
2411	2411	3.0 SPPR Processor
2412	2412	6.1 SPPR Processor
2413	2531	E06 Processor
2414	2585	F02 Processor
2416	24C4	#1544 interactive 8/12-way 840 POD
2416	24C6	#1546 interactive 8/12-way 840 POD
2416	24C3	#1543 interactive 8/12-way 840 POD
2416	24C2	#1542 interactive 8/12-way 840 POD
2416	24C0	#1540 interactive 8/12-way 840 POD
2416	2416	Model 840 8/12-way POD
2416	24C5	#1545 interactive 8/12-way 840 POD
2416	24C1	#1541 interactive 8/12-way 840 POD
2417	24CD	#1545 interactive 12/18-way 840 POD
2417	24CE	#1546 interactive 12/18-way 840 POD
2417	24CC	#1544 interactive 12/18-way 840 POD
2417	2417	Model 840 12/18-way POD
2417	24CB	#1543 interactive 12/18-way 840 POD
2417	24CA	#1542 interactive 12/18-way 840 POD
2417	24C9	#1541 interactive 12/18-way 840 POD
2417	24C8	#1540 interactive 12/18-way 840 POD
2418	23E9	840 (10000 CPW) with #1541 Interact.
2418	2418	Model 840 12-way Processor
2418	23E8	840 (10000 CPW) with #1540 Interact.
2418	23ED	840 (10000 CPW) with #1545 Interact.
2418	23EC	840 (10000 CPW) with #1544 Interact.
2418	23EB	840 (10000 CPW) with #1543 Interact.
2418	23EA	840 (10000 CPW) with #1542 Interact.
2418	23EE	840 (10000 CPW) with #1546 Interact.
2419	24D5	#1545 interactive 18/24-way 840 POD
2419	24D0	#1540 interactive 18/24-way 840 POD
2419	24D2	#1542 interactive 18/24-way 840 POD
2419	2419	Model 840 18/24-way POD
2419	24D1	#1541 interactive 18/24-way 840 POD
2419	24D7	#1547 interactive 18/24-way 840 POD
2419	24D6	#1546 interactive 18/24-way 840 POD
2419	24D4	#1544 interactive 18/24-way 840 POD
2419	24D3	#1543 interactive 18/24-way 840 POD

Feat. code	CCIN	Description
2420	23F8	840 (16500 CPW) with #1540 Interact.
2420	2420	Model 840 24-way Processor
2420	23FD	840 (16500 CPW) with #1545 Interact.
2420	23FF	840 (16500 CPW) with #1547 Interact.
2420	23FE	840 (16500 CPW) with #1546 Interact.
2420	23FA	840 (16500 CPW) with #1542 Interact.
2420	23FC	840 (16500 CPW) with #1544 Interact.
2420	23F9	840 (16500 CPW) with #1541 Interact.
2420	23FB	840 (16500 CPW) with #1543 Interact.
2422	2422	Dedicated Domino Processor
2423	2423	Dedicated Domino Processor
2424	2424	Dedicated Domino 2-way Processor
2425	2425	Dedicated Domino Processor
2426	2426	Dedicated Domino 2-way Processor
2427	2427	Dedicated Domino 4-way Processor
2431	23E7	Model 270 Processor with #1518
2431	2431	Model 270 Processor
2432	23F1	Model 270 Processor with #1519
2432	25BA	Model 270 Processor
2432	23F0	Model 270 Processor with #1516
2434	2434	Model 270 2-way Processor
2434	23F5	Model 270 Processor with #1520
2434	23F4	Model 270 Processor with #1516
2435	249D	Model 820 Processor with #1523
2435	249C	Model 820 Processor with #1522
2435	2435	Model 820 Processor
2435	249B	Model 820 Processor with #1521
2435	249E	Model 820 Processor with #1524
2436	2436	Model 820 Processor
2436	24A8	Model 820 Processor with #1521
2436	24A9	Model 820 Processor with #1522
2436	24AA	Model 820 Processor with #1523
2436	24AB	Model 820 Processor with #1524
2436	24AC	Model 820 Processor with #1525
2437	24B0	Model 820 Processor with #1521
2437	24B1	Model 820 Processor with #1522
2437	24B5	Model 820 Processor with #1526
2437	24B2	Model 820 Processor with #1523
2437	24B4	Model 820 Processor with #1525
2437	2437	Model 820 2-way Processor
2437	24B3	Model 820 Processor with #1524
2438	24BD	Model 820 Processor with #1526
2438	24BC	Model 820 Processor with #1525
2438	24BE	Model 820 Processor with #1527
2438	24BB	Model 820 Processor with #1524
2438	24B8	Model 820 Processor with #1521
2438	24B9	Model 820 Processor with #1522
2438	24BA	Model 820 Processor with #1523
2438	2438	Model 820 4-way Processor
2452	25BA	Dedicated Domino Processor
2452	2452	Dedicated Domino Processor
2454	2454	Dedicated Domino 2-way Processor
2456	2456	Dedicated Domino Processor
2457	2457	Dedicated Domino 2-way Processor
2458	2458	Dedicated Domino 4-way Processor
2461	26D6	Model 840 24-way Processor with #1546

Feat. code	CCIN	Description
2461	26D2	Model 840 24-way Processor with #1542
2461	26D4	Model 840 24-way Processor with #1544
2461	26D5	Model 840 24-way Processor with #1545
2461	26D0	Model 840 24-way Processor with #1540
2461	26D7	Model 840 24-way Processor with #1547
2461	26D8	Model 840 24-way Processor with #1548
2461	2461	Model 840 24-way Processor
2461	26D1	Model 840 24-way Processor with #1541
2463	25B9	Model 800 Processor
2464	25BA	Model 800 Processor
2465	25BA	Model 810 Processor
2466	25BA	Model 810 Processor
2467	25F0	Model 810 Processor
2469	25EB	Model 810 2-way Processor
2473	2473	Model 825 3/6-way Processor
2486	2486	Model 870 8/16-way Processor
2487	2487	Model 890 16/24-way Processor
2488	2488	Model 890 24/32-way Processor
2497	2487	Model 890 16/24-way Processor
2498	2488	Model 890 24/32-way Processor
2515	2515	C10 Floating Pt Processor
2516	2516	C20 Floating Pt Processor
2523	2523	D80 Processor
2525	2525	D02 Processor
2528	2528	16.8 SPPR CPU for Model F97
2530	2530	E04 Processor
2533	2533	E20 Processor
2534	2534	E25 Processor
2536	2536	E35 Processor
2537	2537	E45 Processor
2539	2539	E02 Twinaxial
2540	2540	0.7 SPPR CPU for Model D35
2541	2541	D45 Processor
2542	2542	D50 Processor
2543	2543	D60 Processor
2544	2544	D70 Processor
2552	2552	C06 Processor
2553	2553	D06 Processor
2554	2554	D04 Processor
2555	2555	D10 Processor
2556	2556	D20 Processor
2557	2557	D25 Processor
2558	2558	C04 Processor 8 MB
2559	2559	E50 Processor
2560	2560	E60 Processor
2561	2561	E70 Sort Processor
2562	2562	E80 Sort Processor
2563	2563	E90 (2way) Sort
2568	2568	E95 (2way) Sort
2582	2582	F06 Processor
2583	2583	F25 Processor
2586	2586	0.7 SPPR for F04

Feat. code	CCIN	Description
2587	2587	F10 Processor
2588	2588	F20 Processor
2591	2591	Ext. 1.44 GB Diskette Drive
2592	2592	F35 Processor
2593	2593	F45 Sort Processor
2594	2594	F50 Processor
2595	2595	F60 Sort Processor
2596	2596	F70 Processor 1-way
2597	2597	F80 Processor 2-way
2598	2598	F90 Processor 2-way
2599	259A	F95 Processor 2-way
2600	2600	Magnetic Storage Controller
2601	2601	9346 Mag Tape Unit Controller
2602	2602	Processor Expansion
2604	2604	3422 3430 Mag Tape Subsys
2605	2605	ISDN Basic Rate Adapter
2607	2602	9348 Mag Tape Unit Attach
2608	2608	2440/9348 HCD Mag Tape Att
2609	2609	EIA 232/V.24 2-Line Adapt
2610	2610	X.21 2-Line Adapter
2611	2611	DASD Controller
2612	2612	EIA 232/V.24 1-Line Adapt
2613	2613	V.35 1-Line Adapter
2614	2614	X.21 1-Line Adapter
2617	2617	Ethernet/IEEE 802.3 CSMA/CD
2618	2618	Fiber Distributed Data Adapt
2619	2619	16/4 Mbps Token-Ring Adapter
2620	2620	Cryptographic Processor
2621	2621	Removable Media Device Attach
2622	2622	3490 Magnetic Tape Attach
2623	2623	Six-Line Comm Controller
2624	2624	Storage Device Controller
2625	2625	Ethernet/IEEE 802.3 CSMA/CD
2626	2626	16/4 Mbps Token-Ring Adapter/A
2628	2628	Cryptographic Processor-Comm
2629	2629	LAN/WAN/Workstation IOP
2634	2634	16/4 Mbps Token-Ring Adapter
2636	2636	16/4 Mbps Token-Ring Adapter
2640	6337	DVD-ROM Slimline Drive
2644	2644	34xx Magnetic Tape Attachment
2647	2647	9348 Model 2 Tape Attachment
2654	2609	EIA 232/V.24 2-Line 20E
2655	2609	EIA 232/V.24 2-Line 20
2656	2610	X.21 2-Line 20
2657	2609	EIA 232/V.24 2-Line 50E
2658	2609	EIA 232/V.24 2-Line 50
2659	2610	X.21 2-Line 50
2663	2663	I/O Attachment Processor
2664	2664	Integrated Fax Adapter
2665	2665	Copper Dist Data Interface
2666	2666	Frame Relay Adapter
2668	2668	AS/400 Wireless LAN Adapter
2669	2669	Shared Bus Interface Card
2670	2670	System Unit Expansion Tower (optical)
2671	2671	PCI Bus IOP
2672	2672	PCI Bus IOP
2673	2673	Optical Bus Adapter
2674	2674	Optical Bus Adapter

Feat. code	CCIN	Description
2680	2680	Optical Bus Receiver-266 Mbps
2682	2682	Optical Bus Receiver (1063 Mbps)
2683	2683	266 Mbps OptiConnect Receiver
2685	2685	1063 Mbps OptiConnect Receiver
2686	2686	Optical Link Processor (266 Mbps)
2688	2688	Optical Link Processor (1063 Mbps)
2691	2691	Optical Bus Adapt w/Token Ring
2692	2692	Optional Bus Adapt w/Ethernet
2693	2693	Optional Bus Adapt w/Token Ring
2694	2694	Optional Bus Adapt w/Ethernet
2695	2695	Optical Bus Adapter
2699	2699	2-Line WAN IOA
2705	2705	M1 Filler Tray
2706	2706	M2 Terminator Tray
2713	2713	SPD I/O Regulator
2715	2715	Processor/Memory Regulator
2718	2718	PCI Magnetic Media Controller
2720	2720	PCI WAN/Twinaxial IOA
2721	2721	PCI 2-Line WAN IOA
2722	2722	PCI Twinaxial Workstation IOA
2723	2723	PCI Ethernet IOA
2724	2724	PCI 16/4 Mbps Token-Ring IOA
2726	2726	PCI RAID Disk Unit Controller
2729	2729	PCI Magnetic Media Controller
2730	2730	Programmable Regulator
2732	2732	PCI Serial HIPPI Adapter
2735	2735	Optical Bus Adapter
2736	2736	Optical Bus Adapter
2737	2737	PCI USB 1.1 Adapter
2738	2738	HSL Ports - 8 Copper
2739	2739	Optical Bus Adapter
2740	2740	PCI RAID Disk Unit Controller
2741	2741	PCI RAID Disk Unit Controller
2742	2742	PCI 2-Line WAN IOA
2743	2743	PCI 1 Gbps Ethernet IOA
2744	2744	PCI 100 Mbps Token-Ring IOA
2745	2745	PCI 2-Line WAN IOA
2746	2746	PCI Twinaxial Workstation IOA
2748	2748	PCI RAID Disk Unit Controller
2749	2749	PCI Ultra Mag Media Controller
2750	2750	PCI ISDN BRI U IOA
2751	2751	PCI ISDN BRI S/T IOA
2754	2754	HSL Ports - 8 Copper
2755	2755	HSL Ports -16 Copper
2757	2757	PCI-X Ultra RAID Disk Ctrl
2758	2758	HSL Ports - 2 Optical/ 6 Copper
2759	2759	HSL Ports - 4 Optical/12 Copper
2760	2760	PCI 1 Gbps Ethernet UTP IOA
2761	2761	PCI Integrated Analog Modem
2763	2763	PCI RAID Disk Unit Controller
2765	2765	PCI Fibre Channel Tape Controller
2766	2766	PCI Fibre Channel Disk Controller
2768	2768	PCI Magnetic Media Controller
2772	2772	PCI Dual WAN/Modem IOA
2773	2772	PCI Dual WAN/Modem IOA(ANSI)
2774	2758	HSL Ports - 2 Optical/ 6 Copper
2776	2776	HSL-2 Ports - 8 Copper
2777	2754	HSL Ports - 8 Copper

Feat. code	CCIN	Description
2778	2778	PCI RAID Disk Unit Controller
2780	2780	PCI Ultra 4 SCSI Disk Ctrl
2782	2782	PCI-X RAID Disk Unit Controller
2785	2785	HSL-2 Ports - 2 Copper
2786	2786	HSL Ports - 2 Optical
2788	2788	HSL Ports - 8 Optical
2789	2789	HSL Ports - 4 Optical
2790	2890	PCI Integrated Netfinity Server
2791	2890	PCI Integrated xSeries Server
2792	2892	PCI Integrated xSeries Server
2793	2793	PCI 2-Line WAN w/Modem
2794	2793	PCI 2-Line WAN w/Modem (CIM)
2795	2895	128 MB Server Memory
2796	2896	256 MB Server Memory
2797	2897	1 GB Server Memory
2799	2890	PCI Integ xSeries Server
2799	2799	#2799 PCI Integrated xSeries Server
2801	2801	1.96 GB Internal Disk Unit
2802	2802	2.0 GB Internal Disk Unit
2805	2805	PCI Quad Modem IOA
2806	2805	PCI Quad Modem IOA (CIM)
2809	2809	PCI LAN/WAN/Workstation IOP
2810	2810	LAN/WAN IOP
2811	2811	PCI 25 Mbps UTP ATM
2812	2812	PCI 45 Mbps Coax T3/DS3 ATM
2813	2813	PCI 155 Mbps MMF ATM
2814	2813	PCI 100 Mbps MMF ATM
2815	2815	PCI 155 Mbps UTP OC3 ATM
2816	2816	PCI 155 Mbps MMF ATM
2817	2817	PCI 155 Mbps MMF ATM
2818	2818	PCI 155 Mbps SMF OC3 ATM
2819	2819	PCI 34 Mbps Coax E3 ATM
2824	2824	PCI LAN/WAN/Workstation IOP
2830	2830	Main Storage Expansion
2838	2838	PCI 100/10 Mbps Ethernet IOA
2842	2842	PCI IOP
2843	2843	PCI IOP
2844	2844	PCI IOP
2847	2847	Fibre Channel IOP for SAN load source
2849	2849	PCI 100/10 Mbps Ethernet IOA
2850	2850	Integrated PC Server 32 MB
2851	2850	PCI Integrated PC Server
2852	2850	PCI Integrated PC Server
2853	2853	3450 0.66m system to device cable
2854	2850	PCI Integrated PC Server
2855	2855	3450 1.2m system to device cable
2856	2856	3450 1.2m system to device cable
2857	2850	PCI Integrated PC Server
2858	2850	FSIOA 128 MB Memory Keyboard Mouse
2860	2860	16 MB IOP Memory
2861	2861	32 MB IOP Memory
2862	2862	128 MB IOP Memory
2863	2863	Cable, Artic960HX
2864	2864	Cable, Artic960HX
2865	2850	PCI Integ Netfinity Server
2866	2850	PCI Integ Netfinity Server
2867	2867	256 MB IOP Memory

Feat. code	CCIN	Description
2868	2850	PCI Integ Netfinity Server
2877	2877	Cable H.100 BUS
2881	2881	Main Storage Expansion
2884	2884	Main Storage Expansion
2886	2886	Optical Bus Adapter
2887	2887	HSL-2 Bus Adapter
2888	2888	HSL-2/RIO-G Ports - 2 Copper
2890	2890	PCI Integ Netfinity Server
2891	2890	PCI Integ xSeries Server
2892	2892	PCI Integ xSeries Server
2895	2895	128 MB Server Memory
2896	2896	256 MB Server Memory
2897	2897	1 GB Server Memory
2899	2890	PCI Integ xSeries Server
2934	2934	Async Term/Printer Cable
2936	2936	Async Modem Cable-EIA232/188
2943	2943	8-port EIA232/422 Adapter
2946	2946	622 MBS ADM Fiber Adpt
2947	2947	Artic960HX Adpt
2951	2951	Hermosa cable EIA232
2952	2952	Hermosa cable V.35
2953	2953	Hermosa V.36
2954	2953	Hermosa cable X.21
3000	3002	Migrated 128 MB Main Storage
3001	3001	32 MB Main Storage
3002	3002	128 MB Main Storage
3003	3003	256 MB Main Storage
3004	3004	256 MB Main Storage
3005	3005	512 MB Main Storage
3006	3006	512 MB Main Storage
3007	3007	1 GB Main Storage
3009	3009	128 MB Main Storage
3015	3015	8 GB Main Storage
3016	3016	8 GB Main Storage
3017	3017	32 GB Main Storage
3018	3018	32 GB Main Storage
3020	3020	4 GB Main Storage
3021	3021	4 GB Main Storage
3022	3022	128 MB Main Storage
3024	3024	256 MB Main Storage
3025	3025	512 MB Main Storage
3026	3026	512 MB Main Storage
3027	3027	1 GB Main Storage
3029	3029	128 MB Main Storage
3032	3032	256 MB Main Storage
3033	3033	512 MB Main Storage
3034	3034	1 GB Main Storage
3035	3035	16 GB Main Storage
3036	3036	16 GB Main Storage
3037	3037	64 GB Main Storage PDIMM
3038	3038	64 GB Main Storage PDIMM
3042	3042	256 MB Main Storage
3043	3043	512 MB Main Storage
3044	3044	1024 MB Main Storage
3045	3045	1024 MB Main Storage
3046	3046	2048 MB Main Storage
3054	3054	4 MB Additional Main Storage
3055	3055	8 MB Additional Main Storage

Feat. code	CCIN	Description
3060	3060	16 MB Additional Main Storage
3061	3061	16 MB Additional Main Storage
3062	3002	128 MB Main Storage
3064	3004	256 MB Main Storage
3065	3005	512 MB Main Storage
3066	3006	512 MB Main Storage
3067	3007	1 GB Main Storage
3092	3092	256 MB Main Storage
3093	3093	512 MB Main Storage
3094	3094	1024 MB Main Storage
3095	3095	1024 MB Main Storage
3096	3096	2048 MB Main Storage
3100	3100	16 MB Main Storage
3101	3101	32 MB Main Storage
3102	3102	16 MB Main Storage
3103	3103	32 MB Main Storage
3104	3104	64 MB Main Storage
3108	3108	8 MB Main Storage
3109	3109	32 MB Main Storage
3110	3110	64 MB Main Storage
3116	3116	MFIO Storage Expansion
3117	3117	8 MB Main Storage
3118	3118	16 MB Main Storage
3119	3119	8 MB Main Storage
3120	3120	8 MB Main Storage
3121	3121	8 MB Main Storage
3122	3122	32 MB Main Storage
3130	3130	32 MB Main Storage
3131	3131	64 MB Main Storage
3132	3132	128 MB Main Storage
3133	3133	64 MB Main Storage
3134	3134	128 MB Main Storage
3135	3135	256 MB Main Storage
3136	3136	256 MB Main Storage
3138	3138	64 MB Main Storage
3140	3140	8 MB Main Storage
3141	3141	16 MB Main Storage
3142	3142	32 MB Main Storage
3144	3144	8 MB Main Storage
3145	3145	16 MB Main Storage
3146	3146	32 MB Main Storage
3147	3147	32 MB Main Storage
3149	3149	128 MB Main Storage
3152	3152	32 MB Main Storage
3153	3153	64 MB Main Storage
3154	3154	128 MB Main Storage
3155	3155	256 MB Main Storage
3156	3156	64 MB Main Storage
3157	3157	128 MB Main Storage
3158	3158	256 MB Main Storage
3159	3159	8 MB Main Storage
3160	3160	16 MB Main Storage
3161	3161	32 MB Main Storage
3162	3162	128 MB Main Storage
3163	3163	256 MB Main Storage
3164	3164	512 MB Main Storage
3165	3165	1024 MB Main Storage
3166	3166	256 MB Main Storage

Feat. code	CCIN	Description
3172	3172	32 MB Main Storage (2 SIMMs)
3179	3179	256 MB Main Storage
3180	3180	512 MB Main Storage
3182	3172	32 MB Main Storage
3184	3184	32 MB Main Storage
3185	3185	64 MB Main Storage
3186	3186	128 MB Main Storage
3187	3187	256 MB Main Storage
3189	3189	128 MB Main Storage
3190	3190	256 MB Main Storage
3191	3191	512 MB Main Storage
3192	3192	1024 MB Main Storage
3193	3193	2048 MB Main Storage
3195	3195	4096 MB Main Storage
3196	3196	8192 MB Main Storage
3197	3197	1024 MB Main Storage
3198	3198	2048 MB Main Storage
3612	3612	1024 MB Main Storage
3613	3613	2048 MB Main Storage
3614	3614	4096 MB Main Storage
3628	3628	Black P260/P275 Color
3637	3637	T541H/L150PTFT Color
3638	3638	Black C220P Color Monitor
3639	3639	Black L170P TFT Display
3641	3641	T115 TFT 15" Color Display
3643	3643	T120 TFT 20" Color Display
3644	3644	T119 TFT 19" Color Display
3645	3645	T117 TFT 17" Color Display
4010	4010	4 MB Write Cache
4011	4011	8 MB Data Store
4012	4012	32 MB Data Store
4103	3103	32 MB Main Storage
4104	4104	4 MB Main Storage
4114	4114	4 MB Main Storage Expansion
4117	3117	8 MB Main Storage SIMM
4118	3118	16 MB Main Storage SIMM
4120	3120	8 MB Main Storage
4121	3121	8 MB Main Storage
4122	3122	32 MB Main Storage
4133	3133	64 MB Main Storage
4134	3134	128 MB Main Storage
4135	3135	256 MB Main Storage
4136	3136	256 MB Main Storage
4138	3138	64 MB Main Storage
4144	3144	8 MB Main Storage
4145	3145	16 MB Main Storage
4146	3146	32 MB Main Storage
4147	3147	32 MB Main Storage
4149	3149	128 MB Main Storage
4156	3156	64 MB Main Storage
4157	3157	128 MB Main Storage
4158	3158	256 MB Main Storage
4161	3161	32 MB Main Storage
4172	3172	32 MB Main Storage
4204	3104	64 MB Main Storage
4205	6605	Addt Disk Unit (1.031 GB)
4206	6606	Addt Disk Unit (1.967 GB)
4207	6607	Addt Disk Unit (4.194 GB)

Feat. code	CCIN	Description
4211	6602	Addt Disk Unit (1.031 GB)
4212	6603	Addt Disk Unit (1967 MB)
4263	4263	Direct Attach Tape Cables
4270	292C	#4270 - Ctlr to External Port Cable
4308	6607	4.19 GB Disk Unit
4314	6713	8.58 GB Disk Unit
4317	6717	8.58 GB 10k rpm Disk Unit
4318	6718	17.54 GB 10k rpm Disk Unit
4319	6719	35.16 GB 10k rpm Disk Unit
4324	6714	17.54 GB Disk Unit
4326	4326	35.16 GB 15k rpm Disk Unit
4327	4327	70.56 GB 15k rpm Disk Unit
4328	4328	141.12 GB15k rpm Disk Unit
4331	6731	1.6 GB Read Cache Device
4332	4332	Fibre Channel Loop Ctlr
4400	313A	1 GB DDR2 Main Storage
4425	6321	CD-ROM
4430	6330	DVD-RAM
4431	6336	DVD-ROM
4443	309B	512 MB DDR
4444	309B	1 GB DDR DIMMs
4445	30D3	4 GB DDR DIMMs
4447	30D2	2 GB DDR DIMMs
4449	30D5	8 GB DDR DIMMs
4450	30AC	16 GB DDR DIMMs
4452	309D	2 GB Memory (4x512 MB DIMMs)
4453	309F	4 GB Memory (4x1 GB DIMMs)
4454	30AA	8 GB Memory (4x2 GB DIMMs)
4474	313B	2 GB DDR2 Main Storage
4475	313D	4 GB DDR2 Main Storage
4477	313E	8 GB DDR2 Main Storage
4482	63A0	4 GB ¼-inch Cartridge Tape
4483	63A0	16 GB ¼-inch Cartridge Tape
4486	63A0	25 GB ¼-inch Cartridge Tape
4487	63A0	50 GB ¼-inch Cartridge Tape
4490	309E	4 GB Memory (4x1 GB DIMMs)
4491	30B3	16 GB Memory (4x4 GB DIMMs)
4492	30F7	32 GB Memory (4x8 GB DIMMs)
4495	316F	4/8 GB DDR2 Main Storage
4496	314E	8/16 GB DDR2 Main Storage
4497	312F	16 GB DDR2 Main Storage
4498	314C	32 GB DDR2 Main Storage
4525	6321	CD-ROM
4530	6330	DVD-RAM
4531	6336	DVD-ROM
4533	6333	DVD-RAM
4582	63A0	4 GB ¼-inch Cartridge Tape
4583	63A0	16 GB ¼-inch Cartridge Tape
4584	63A0	30 GB ¼-inch Cartridge Tape
4585	63A0	80 GB VXA-2 Tape Drive
4685	63A0	80 GB VXA-2 Tape Drive
4586	63A0	25 GB ¼-inch Cartridge Tape
4587	63A0	50 GB ¼-inch Cartridge Tape
4605	6605	Addt Disk Unit (1.031 GB, reg)
4606	6606	Single Disk Unit (1967 MB)
4607	6607	Addt Disk Unit (4.194 GB, reg)
4625	6321	CD-ROM
4630	6330	DVD-RAM

Feat. code	CCIN	Description
4631	6336	DVD-ROM
4633	6333	DVD
4650	6603	Additional Disk Unit (1.967 GB, reg)
4652	6602	Single Disk Unit (1031 MB)
4682	63A0	4 GB ¼-inch Cartridge Tape
4683	63A0	16 GB ¼-inch Cartridge Tape
4684	63A0	30 GB ¼-inch Cartridge Tape
4685	63A0	80 GB VXA-2 Tape Drive
4686	63A0	25 GB ¼-inch Cartridge Tape
4687	63A0	50 GB ¼-inch Cartridge Tape
4690	4690	Rack Status Beacon Assem
4691	4691	Rack Status Beacon Cable
4692	4692	Junction Box Cable
4693	4693	Rack Beacon Junction box
4710	2892	#4710 PCI Integrated xSeries Server
4723	2723	PCI 10 Mbps Ethernet IOA
4745	2745	PCI 2-Line WAN IOA
4746	2746	PCI Twinaxial Workstation IOA
4748	2748	PCI RAID Disk Unit Controller
4750	2750	#4750 PCI ISDN BRI U IOA
4751	2751	PCI ISDN BRI S/T IOA
4761	2761	PCI Integrated Analog Modem
4778	2778	PCI RAID Disk Unit Controller
4800	4758	PCI Crypto Coprocessor
4801	4758	PCI Crypto Coprocessor
4802	4758	PCI Crypto Coprocessor
4805	2058	PCI Crypto Accelerator
4806	4764	PCI-X Cryptographic Coprocessor
4810	2892	#4810 PCI Integrated xSeries Server
4811	4812	#4811 PCI Integrated xSeries Server
4812	4812	#4812 PCI Integrated xSeries Server
4813	4812	#4813 PCI Integrated xSeries Server
4815	2815	PCI 155 Mbps UTP OC3 ATM
4816	2816	PCI 155 Mbps MMF ATM
4818	2818	PCI 155 Mbps SMF OC3 ATM
4838	2838	PCI 100/10 Mbps Ethernet IOA
4953	4953	155 MBps ATM UTP Adapter
4957	4957	155 MBps ATM Fiber Adapter
4959	4959	4/16 Token ring adpt/
4960	4960	Crypto SSL HW Accelerator
4961	4961	240V, 6ft, 30A Line Cord
4962	4962	Ethernet/LAN Encryption
4963	4963	Cryptographic Coprocessor
5033	5033	#5033 Migration Tower I
5034	5034	#5034 Migration Tower I
5035	5035	#5035 Migration Tower I
5066	5066	1.8 M I/O Tower
5078	5078	PCI Expansion Unit
5079	5079	1.8 M I/O Tower
5088	5088	PCI-X Expansion Unit
5094	5094	PCI-X Expansion Tower
5097	5097	1.8M I/O Rack
5111	5111	#5111 30 Disk Expansion with Dual Line Cord
5121	5121	Power Regulator Card
5130	5130	Tower Attach Power (RISC)
5133	5133	Feature Power Supply
5134	5133	Feature Power Supply

Feat. code	CCIN	Description
5135	5135	Feature Power Supply
5136	5136	Feature Power Supply
5138	515F	Redundant Power and Cooling
5140	5140	Regulator
5141	5141	3.6V I/O Regulator
5142	5142	Tower Attach Power
5143	5143	Feature Power Supply (400W)
5144	5144	BBU External (Optional)
5145	5145	BBU Internal (Optional)
5146	5146	Redundant Power (Bulk Reg)
5147	5147	Feature Power -560W
5148	5148	Addtl Battery Backup Internal
5149	5149	Redundant Power (Bulk Reg)
5150	5150	Battery Backup (External)
5151	5151	Power Supply (650 Watts)
5152	5152	Feature Power Supply (500W)
5153	5153	Redundant Power Supplies
5156	5156	#5156 Redundant Power and Cooling
5157	5157	#5157 Feature Power Supply
5158	51B6	850 W Power Supply
5159	5159	850 W Power Supply
5160	5160	#5160 Power Distribution Unit
5161	5161	#5161 Power Distribution Unit
5162	5162	#5162 Power Distribution Unit
5163	5163	Power Dist Unit 3 Phase PDU
5229	5229	Model 520 2-way Processor
5230	522A	Model 520 1-way Processor
5343	6343	Base Tape Replace (1.2 GB)
5348	6348	Base Tape Replace (1.2 GB)
5349	6349	Base Tape Replace (2.5 GB)
5550	n/a	Sys Console on HMC
5553	n/a	Sys Console-Ethernet w/o IOP
5554	n/a	Mirror 35 GB Disk/Ctrl Package
5555	n/a	Mirror 70 GB Disk/Ctrl Package
5556	n/a	Mirror 141.12 GB Disk/Ctrl Package
5557	n/a	Sys Console-Ethernet w/o IOP
5560	n/a	Mirror 35 GB Drawer Package
5561	n/a	Mirror 70 GB Drawer Package
5562	n/a	Mirror 35 GB Tower Package
5563	n/a	Mirror 70 GB Tower Package
5564	n/a	Mirror 141.12 GB Drawer Package
5580	2780 5708	RAID Disk Unit Controller with auxiliary Write Cache
5581	2757 5708	RAID Disk Unit Controller with auxiliary Write Cache
5700	5700	#5700 PCI 1 Gbps Ethernet IOA
5701	5701	PCI 1 Gbps Ethernet UTP IOA
5702	5702	#5702 PCI-X Ultra Tape Controller
5703	5703	PCI-X RAID Disk Controller
5705	5702	#5705 PCI-X Tape/DASD Controller
5706	5706	10/100/1000 Mbps Ethernet Fiber
5706	5706	Dual Port Gigabit Ethernet
5707	5707	10/100/1000 Mbps Ethernet UTP
5707	5707	PCI 1 Gbps Ethrnt 2- port
5709	5709	Ultra320 SCSI Raid
5712	5702	Ultra320 SCSI
5713	573B	PCI-X 1 Gbps iSCSI TOE-Copper
5714	573C	PCI-X 1 Gbps iSCSI

Feat. code	CCIN	Description
5715	5702	PCI-X Tape/DASD Controller
5718	5718	10 GB Ethernet (Fiber)
5727	573D	Integrated Cache - 40 MB
5728	573D	Integrated Cache - 40 MB
5736	571A	PCI-X Disk/Tape Ctrl w/IOP
5737	571B	PCI-X Disk Ctrl-90 MB w/IOP
5740		1 Gbps BaseT Ethernet (4-Port)
5750	6337	DVD-ROM - Slim Line
5751	6331	DVD-RAM
5752	6333	DVD-RAM
5753	63A0	30 GB ¼-inch Cartridge Tape
5754	63A0	50 GB ¼-inch Cartridge Tape
5760	280E	PCI-X Fibre Channel Disk Ctrl
5761	280D	PCI-X Fibre Channel Tape Ctrl
5766	571A	PCI-X Tape Controller
5775	571A	PCI-X Disk/Tape Ctrl-w/o IOP
5776	571B	PCI-X Disk Ctrl-90 MB w/o IOP
6001	6001	SPCN Power Cable - 2 m
6006	6006	SPCN Power Cable - 3 m
6007	6007	SPCN Power Cable - 15 m
6008	6008	SPCN Power Cable - 6 m
6029	6029	SPCN Power Cable - 30 m
6040	6040	Twinaxial Workstation Controller
6041	6041	ASCII Workstation Controller
6050	6050	Twinaxial Workstation Controller
6054	6054	Local Talk Controller
6068	6068	Opt Front Door for 1.8m Rack
6100	6100	Disk Unit (315 MB)
6103	6103	Single Disk Unit (400 MB)
6105	6105	Single Disk Unit (320 MB)
6107	6107	Single Disk Unit (400 MB)
6108	6105	Additional Dual Disk (640 MB)
6109	6109	Single Disk Unit (988 MB)
6110	6110	Magnetic Storage Dev Controller
6111	6111	Magnetic Storage Dev Controller
6112	6112	Magnetic Storage Device Controller
6120	6107	Dual Disk Unit (800 MB)
6121	6107	Additional Dual Disk (800 MB)
6123	6109	Additional Dual Disk (1976 MB)
6124	6109	Base DASD Upgrade (1976 MB)
6125	6109	Base DASD Replace (988 MB)
6126	6104	Base DASD Replace (988 MB)
6127	6109	Base DASD Replace (1976 MB)
6134	6134	60 GB 8 mm Tape Unit
6140	6140	Twinaxial Workstation Controller
6141	6141	ASCII Workstation Controller
6146	6146	Diskette Adapter
6147	6147	Diskette Adapter
6148	6148	8-Port Twinaxial Expansion
6149	6149	16/4 Mbps Token-Ring IOA
6150	6150	Three-Line Communication Controller
6151	6151	X.21 1-Line 20
6152	6152	EIA 232/V.24 Adapter
6153	6153	V.35 1-Line (20-ft Cable)
6154	6152	EIA 232/V.24 1-Line 20E
6155	6152	EIA 232/V.24 1-Line 20
6160	6160	Token-Ring Network Adapter
6171	6151	X.21 1-Line 50

Feat. code	CCIN	Description
6173	6153	V.35 1-Line (50-ft Cable)
6174	6152	EIA 232/V.24 1-Line 50E
6175	6152	EIA 232/V.24 1-Line 50
6180	6180	Twinaxial Workstation IOA
6181	6181	Ethernet/IEEE 802.3 IOA
6183	6183	6 port ASCII IOA
6203	6202	PCI Ultra3 SCSI Adapter
6204	6204	Differential SCSI Adapter
6246	6246	1.8 m Rack Trim Kit
6258	6258	36 GB 4 mm Tape Unit
6279	63A0	160 GB VXA-320 Tape Drive
6312	6312	Quad Digital Trunk Adapter
6325	6321	CD-ROM
6335	6335	840 MB QIC-mini Tape Unit
6340	6340	13 GB QIC mini Tape Unit
6341	6341	120 MB ¼-in Cartridge Tape
6342	6342	525 MB ¼-inch Cartridge Tape
6343	6343	1.2 GB ¼-inch Cartridge Tape
6344	6344	2.5 GB ¼-in Cartridge Tape
6345	6345	13 GB ¼-in Cartridge Tape
6346	6346	120 MB ¼-in Cartridge Tape
6347	6347	525 MB ¼-in Cartridge Tape
6348	6348	1.2 GB ¼-in Cartridge Tape
6349	6349	2.5 GB ¼-in Cartridge Tape
6350	6350	13 GB ¼-in Cartridge Tape
6365	6335	840 MB QIC-mini Tape External
6366	6366	120 MB ¼-in Cartridge Tape
6367	6366	525 MB ¼-in Cartridge Tape
6368	6368	1.2 GB ¼-inch Cartridge Tape
6369	6369	2.5 GB ¼-inch Cartridge Tape
6370	6370	13 GB ¼-in Cartridge Tape
6380	6380	2.5 GB ¼-inch Cartridge Tape
6381	63A0	2.5 GB ¼-inch Cartridge Tape
6382	63A0	4 GB ¼-inch Cartridge Tape
6383	63A0	16 GB ¼-inch Cartridge Tape
6384	63A0	30 GB ¼-inch Cartridge Tape
6385	6385	13 GB ¼-inch Cartridge Tape
6386	63A0	25 GB ¼-inch Cartridge Tape
6390	6390	7 GB 8 mm Cartridge Tape Unit
6417	28E7	HSL-2/RIOG Bus Adapter
6425	6321	CD-ROM
6480	6380	2.5 GB ¼-inch Cart Tape
6481	63A0	2.5 GB ¼-inch Cart Tape
6482	63A0	4 GB ¼-inch Cartridge Tape
6483	63A0	16 GB ¼-inch Cartridge Tape
6484	63A0	30 GB ¼-inch Cartridge Tape
6485	6385	13 GB ¼-inch Cartridge Tape
6486	63A0	25 GB ¼-inch Cartridge Tape
6490	6390	7 GB 8 mm Cartridge Tape
6500	6500	Disk Controller
6501	6501	Tape/Disk Device Controller
6502	6502	Disk Unit Controller for RAID
6509	6509	Additional 16 MB FSIOP Memory
6512	6512	Disk Unit Controller for RAID
6513	6513	Internal Tape Device Controller
6516	6506	16 MB One-Port FSIOP
6517	6506	32 MB One-Port FSIOP
6518	6506	48 MB One-Port FSIOP

Feat. code	CCIN	Description
6519	6506	64 MB One-Port FSIOP
6520	6520	Upgrade 1 to 2 Port FSIOP
6522	6502	Disk Unit Cntrlr for RAID
6523	6530	Disk Unit Controller
6526	6506	16 MB 2-Port FSIOP
6527	6506	32 MB 2-Port FSIOP
6528	6506	48 MB 2-Port FSIOP
6529	6506	64 MB 2-Port FSIOP
6530	6530	Storage Device Controller
6532	6532	RAID Disk Unit Controller
6533	6533	RAID Disk Unit Controller
6534	6534	Magnetic Media Controller
6536	6535	SSA Disk Unit Controller
6537	6535	SSA RAID Disk Unit Controller
6574	28D2	#6574 - 4-Disk Slot Exp - Base Ctlr
6580	6580	Optional Rack Security Kit
6584	28F7	#6584 - 4-Disk Slot Exp - PCI-X Ctlr
6586	6586	Modem Tray for 19-Inch Rack
6587	6587	Model 520 Rear Cover
6592	28F6	#6592 - 4-Disk Slot Exp - Base Ctlr
6593	292E	#6593 - 4-Disk Slot Exp - PCI-X Ctlr
6594	292D	#6594 - 4-Disk Slot Exp-PCI-X Ctlr
6601	6601	Single Disk Unit (1031 MB)
6602	6602	Single Disk Unit (1031 MB)
6603	6603	Single Disk Unit (1967 MB)
6605	6605	1.03 GB Disk Unit
6606	6606	1.96 GB Disk Unit
6607	6607	4.19 GB Disk Unit
6612	6602	Dual Disk Unit (2.0 GB)
6613	6603	Dual Disk Unit (4 GB)
6616	6616	Integrated PC Server
6617	6617	Integrated PC Server
6618	6617	Integrated Netfinity Server
6650	6603	Additional Disk Unit (1.96 GB)
6652	6602	Additional Disk Unit (1.03 GB)
6701	6601	Base Disk Replace (1.0 GB)
6713	6713	8.58 GB Disk Unit
6714	6714	17.54 GB Disk Unit
6717	6717	8.58 GB 10k rpm Disk Unit
6718	6718	17.54 GB 10k rpm Disk Unit
6750	6750	MFIOP
6752	6752	MFIOP
6753	6753	MFIOP
6800	5700	PCI 1 Gbps Ethernet IOA
6801	5701	PCI 1 Gbps Ethernet UTP IOA
6802	6602	Base Disk Replacement (1.0 GB)
6803	2793	PCI WAN for ECS
6804	2793	PCI WAN for ECS (CIM)
6806	6606	1.96 GB Disk Unit
6807	6607	4.19 GB Disk Unit
6812	6602	Base Disk Replacement (2.0 GB)
6813	6713	8.58 GB Disk Unit
6817	6717	8.58 GB 10k rpm Disk Unit
6818	6718	17.54 GB 10k rpm Disk Unit
6824	6714	17.54 GB Disk Unit
6831	6731	1.6 GB Read Cache Device
6863	6863	System i5 Slim-Line Doors
6864	6864	System i5 Acoustic Doors

Feat. code	CCIN	Description
6906	6606	1.96 GB Disk Unit
6907	6607	4.19 GB Disk Unit
7104	7104	System Unit Expansion
7123	283F	DASD Expansion Unit
7124	28BC	DASD Expansion Unit - 5 slot
7127	283F	DASD Expansion Unit
7128	7128	#7128 DASD Expansion Unit
7130	7130	#7130 Expansion Unit Tape Cage
7133	283F	DASD Concurrent Maint Cage
7135	3135	Optional 256 MB Main Storage
7136	28CD	DASD Expansion Unit - 6 slot
7137	28CD	DASD Concurrent Maintenance
7140	7140	520 Express Configuration
7141	7141	520 Express Configuration
7142	7142	520 Express Configuration
7143	7143	520 Express Configuration
7144	7144	520 Express Configuration
7147	7147	Value Edition for #09XX
7148	7148	520 Express Configuration
7152	7152	520 Express Configuration
7154	7154	Standard Edition for #0910
7155	7155	Enterprise Edition for #0910
7157	3157	Optional Base 128 MB Main Storage
7158	3158	Optional Base 256 MB Main Storage
7174	9174	Ethernet IOA
7175	9175	Token Ring IOA
7180	7180	Acoustic Front Door
7181	7181	Easy-Access Front Cover
7182	7182	520 Rack Mount
7183	7183	550 Rack Mount
7186	3186	Optional Base 128 MB Main Storage
7187	3187	Optional Base 256 MB Main Storage
7188	7188	Power Disk Unit - Side Mount
7194	7194	Easy-Access Front Cover
7197	7197	570 Front Bezel
7198	7198	Adjustable Depth Rack Rails
7199	7199	Acoustic Front Door
7255	3155	Optional Base 256 MB Main Storage
7256	7256	520 Enterprise Enablement
7257	7257	550 Enterprise Enablement
7258	7258	570 Full Enterprise Enable
7259	7259	595 Full Enterprise Enable
7260	7260	570 Enterprise Enablement
7261	7261	595 Enterprise Enablement
7263	3163	Optional Base 256 MB Main Storage
7264	3164	Optional Base 512 MB Main Storage
7265	3165	Optional Base 1024 MB Main Storage
7266	3166	Optional Base 256 MB Main Storage
7307	7307	Dual I/O Unit Enclosure
7320	7320	520 One Processor Activation
7323	7323	550 One Processor Activation
7341	7341	550 On/Off Proc Day Billing
7343	6343	1.2 GB ¼-inch Cartridge Tape
7344	6344	2.5 GB ¼-in Cartridge Tape
7347	6347	Base Tape Upgrade (525 MB)
7348	6348	1.2 GB ¼-in Cartridge Tape
7349	6349	2.5 GB ¼-in Cartridge Tape
7350	7350	Value Edition for #0975

Feat. code	CCIN	Description
7352	7352	Value Edition for #0975
7354	7354	Accelerator for System i5
7355	7355	Accelerator for System i5
7357	7357	Accelerator for System i5
7366	7366	Solution Edition for #0906
7373	7337	HA Edition for #0906
7374	7374	HA Edition for #0906
7375	7375	HA Edition for #0906
7390	7390	Model 520 Value/Express Edition
7391	7391	Model 520 Value/Express Edition
7392	7392	Model 520 Value/Express Edition
7393	7391	Model 520 Value/Express Edition
7394	7392	Model 520 Value/Express Edition
7395	7395	Model 520 Value/Express Edition
7396	7396	Model 520 Value/Express Edition
7397	7397	Model 520 Value/Express Edition
7400	7400	Model 800 Value Edition
7404	7404	Model 810 Standard Edition
7404	7404	Package Feature
7406	7406	Model 810 Enterprise Edition
7406	7406	Package Feature
7407	7407	Model 810 Standard/Domino Edition
7408	7408	Model 800 Advanced Edition
7409	7409	Model 810 Enterprise Edition
7410	7410	Model 810 Standard/Domino Edition
7411	7450	Model 520 Express Config
7412	7412	Model 810 Enterprise Edition
7413	7450	Model 520 Express Config
7414	7451	Model 520 Express Config
7416	7416	Model 825 Standard/Domino Edition
7417	7450	Model 520 Express Config
7418	7418	Model 825 Enterprise Edition
7419	7419	Model 870 Standard Edition
7420	7451	Model 520 Express Config
7421	7421	Model 870 Enterprise Edition
7422	7422	Model 890 Standard Edition
7424	7424	Model 890 Enterprise Edition
7425	7425	Model 890 Standard Edition
7427	7427	Model 890 Enterprise Edition
7428	7428	Model 810 Standard/Domino Edition
7429	7429	Model 520 Express Config
7430	7430	Model 810 Enterprise Edition
7431	7431	Model 870 Standard Edition
7433	7433	Model 870 Enterprise Edition
7434	7418	Model 825 High Availability Edition
7435	7433	Model 870 High Availability Edition
7436	7421	Model 870 High Availability Edition
7437	7424	Model 890 High Availability Edition
7438	7427	Model 890 High Availability Edition
7439	7439	Model 870 Capacity BackUp Edition
7440	7440	Model 870 Capacity BackUp Edition
7441	7441	Model 890 Capacity BackUp Edition
7445	7445	Model 810 High Availability Edition
7446	7446	Model 810 High Availability Edition
7447	7447	Model 810 High Availability Edition
7448	7448	Model 810 High Availability Edition
7450	7450	Model 520 Value/Express Edition
7451	7451	Model 520 Value/Express Edition

Feat. code	CCIN	Description
7452	7452	Model 520 Value/Express Edition
7453	7453	Model 520 Enterprise Edition
7454	7454	Model 520 Standard Edition
7455	7455	Model 520 Enterprise Edition
7456	7456	Model 520 Standard Edition
7457	7457	Model 520 Enterprise Edition
7458	7458	Model 520 Standard Edition
7459	7459	Model 520 Enterprise Edition
7462	7462	Model 550 Standard Edition
7463	7463	Model 550 Enterprise Edition
7469	7469	Model 570 0/4-way Standard Edition
7470	7470	Model 570 0/4-way Enterprise Edition
7471	7471	Model 570 0/8-way Standard Edition
7472	7472	Model 570 0/8-way Enterprise Edition
7473	7473	Model 570 0/12-way Standard Edition
7474	7474	Model 570 0/12-way Enterprise Edition
7475	7475	Model 570 0/16-way Standard Edition
7476	7476	Model 570 0/16-way Enterprise Edition
7480	7480	Standard Edition for 8966
7481	7481	Enterprise Edition for 8966
7482	7482	Standard Edition for 8966
7483	7483	Enterprise Edition for 8966
7484	7484	Model 59 32/48-way Standard Edition
7485	7485	Model 595 32/48-way Enterprise Edition
7486	7486	Standard Edition for 8966
7487	7487	Enterprise Edition for 8966
7488	7488	Model 570 0/2-way Standard Edition
7489	7489	Model 570 0/2-way Enterprise Edition
7490	7490	Model 570 0/2-way Standard Edition
7491	7491	Model 570 0/2-way Enterprise Edition
7494	7494	Model 570 2/4-way Standard Edition
7495	7495	Model 570 2/4-way Enterprise Edition
7496	7496	Model 595 8/16-way Standard Edition
7497	7497	Model 595 8/16-way Enterprise Edition
7498	7498	Model 59 16/32-way Standard Edition
7499	7499	Model 595 16/32-way Enterprise Edition
7500	6713	Quantity 150 of #4314
7501	6717	Quantity 150 of #4317
7502	6718	Quantity 150 of #4318
7503	6714	Quantity 150 of #4324
7504	6719	Quantity 150 of #4319
7508	4326	Quantity 150 of #4326
7509	4327	Quantity 150 of #4327
7510	4328	Quantity 150 of #4328
7530	7530	Model 5501/4-way Domino
7531	7531	Model 5501/4-way Solution E1
7532	7532	Model 5501/4-way CRM (Clear Tech w/Domino)
7533	7533	Model 5501/4-way SAP 2-way
7534	7534	Model 5501/4-way SAP 4-way
7541	7541	Model 520 Solution Edition
7551	7551	HA Edition for #0910
7552	7452	Model 520 High Availability Edition
7553	7553	Model 520 High Availability Edition
7554	7554	Model 520 High Availability Edition
7555	7555	Model 520 High Availability Edition

Feat. code	CCIN	Description
7558	7558	Model 5501/4-way Solution
7559	7559	Model 570 High Availability Edition
7560	7560	Model 570 High Availability Edition
7561	7561	Model 570 High Availability Edition
7562	7562	Model 570 High Availability Edition
7563	7563	Model 570 High Availability Edition
7570	7570	Model 570 2/16-way CBU Edition
7580	7580	HA Edition for #0940
7581	7581	HA Edition for #0941
7583	7583	HA Edition for #0943
7590	7590	CBU Edition for #0944
7607	6607	Optional Base 4.19 GB Disk Unit
7613	6603	Base DASD Replace (3934 MB)
7618	7618	570 One Processor Activation
7620	7620	520 On/Off Proc Enablement
7621	7621	520 On/Off Proc Day Billing
7622	7622	520 Reserve Capacity Prepaid
7624	7624	570 On/Off Proc Day Billing
7629	7629	Domino Edition for #0910
7630	7630	Solution Edition for #0910
7631	7631	Sol Ed-PeopleSoft EnterpriseOne
7632	7632	C2CRM Solution Ed w/Domino
7640	7640	2-way SAP Solution Edition
7641	7641	4-way SAP Solution Edition
7663	7663	570 1 GB Mem Activation
7680	7680	Accelerator for System i5
7681	7681	Accelerator for System i5
7682	7682	Accelerator for System i5
7687	7687	Accelerator for System i5
7713	6713	Optional Base 8.58 GB Disk Unit
7728	7625	570 Reserve Capacity Prepaid
7734	7734	Enterprise Edition for #0906
7735	7735	Enterprise Edition for #0906
7736	7736	Enterprise Edition for #0906
7738	7738	570 Base Proc Activation
7741	7741	550 Reserve Capacity Prepaid
7747	7747	Enterprise Edition for #0934
7748	7748	Enterprise Edition for #0935
7749	7749	Enterprise Edition for #0936
7757	7757	Standard Edition for #0934
7758	7758	Standard Edition for #0935
7759	7759	Standard Edition for #0936
7760	7760	CBU Edition for #0937
7763	7763	HA Edition for #0934
7764	7764	HA Edition for #0935
7765	7765	HA Edition for #0936
7768	7768	CPU Power Regulator
7784	7784	Standard Edition for #0906
7785	7785	Standard Edition for #0906
7801	7801	6m HMC Attachment Cable
7802	7802	15m HMC Attachment Cable
7813	528C	0/8 GR 1.8 GHz CUoD MCM
7814	30DC	4 GB Main Storage
7815	7815	595 One Processor Activation
7816	303E	2/4 GB CUoD Main Storage
7817	7817	SNI Fiber Adapter
7818	28D8	HSL-2/RIO-G 2-Ports Copper
7819	28EB	HSL/RIO 2-Ports Optical

Feat. code	CCIN	Description
7828	304E	CUoD 8/16 GB (4X4 GB)
7840	6104	Side-by-side for 1.8m Racks
7841	6080	Ruggedize Rack Pack
7862	7862	Blind Swap Cassette (long)
7863	7863	Blind Swap Cassette (Double)
7864	7864	Blind Swap Cassette (DTXA)
7865	27AE	L/ML CEC Backplane
7866	28DA	I/O PCI Backplane
7867	28D9	L/ML Mid-backplane
7868	28DB	L/ML DASD Backplane
7869	28DC	Removable Media Backplane
7870	28DD	Power Supply Dist Backplane
7875	28E8	L/ML CPU Regulator
7876	291E	Model 520 Media Backplane Card
7877	27AF	Model 520 Power Regulator
7878	25F8	Serial/VPD PCI Card
7879	7879	Headless Enclosure
7880	788A	Model 570 Base Enclosure
7881	28EA	Service Processor
7882	180A	SCSI to IDE Converter Card
7883	28D7	Model 520 SP Card
7884	7884	520 Rack Mount
7885	7885	520 Deskside
7886	7886	SF4 Rack Mount
7887	7887	SF4 Deskside
7890	30DE	4/8 GB CUoD DDR1 Memory
7891	30DF	8/16 GB DDR-1 Main Storage
7892	30F0	512 MB Main Storage DDR2 DIMM
7893	30F2	4 GB Main Storage DDR2 DIMM
7894	30F3	8 GB Main Storage DDR2 DIMM
7897	7897	570 CUoD Proc Activation
7935	30F8	16/32 GB DDR-1 Main Storage
7950	7950	570 1 GB CUoD Mem Activation
7951	7951	570 On/Off Proc Enablement
7952	7952	570 On/Off Proc Day Billing
7954	7954	570 On/Off Mem Enablement
7956	7956	570 Res Cap PrePaid
7957	7957	570 1 GB Mem Day Billing
7971	7971	595 On/Off Proc Enablement
7972	7972	595 On/Off Proc Day Billing
7975	7975	595 Reserve Capacity Prepaid
8052	5052	Optional 16 Disk Unit Expansion
8054	6054	LocalTalk Adapter
8079	9079	Optional Base 1.8 M I/O Rack
8093	8093	Optional Base 1.8 M I/O Rack
8094	8094	Optional Base 1.8 M I/O Rack
8110	6110	Standard Mag Storage Controller
8111	6111	Standard Mag Storage Controller
8123	6109	Dual Disk Unit (1976 MB)
8133	8133	RJ45 to DB25 Interposer
8135	3135	Optional Base 256 MB Main Storage
8136	8136	Remote ASYNC Node (Rack)
8137	8137	Remote ASYNC Node
8152	9152	Optional Base Twinaxial
8156	3156	Optional Base 64 MB Main Storage
8157	3157	Optional Base 128 MB Main Storage
8158	3158	Optional Base 256 MB Main Storage
8160	3160	Optional Addtl 16 MB Main Storage

Feat. code	CCIN	Description
8162	9162	Optional Base MFIOIP w/Twinaxial
8172	3172	Delt Price 32 MB
8180	3180	Optional Base 512 MB Main Storage
8185	3185	Optional Base 64 MB Main Storage
8186	3186	Optional Base 128 MB Main Storage
8187	3187	Optional Base 256 MB Main Storage
8191	3191	Optional Base 512 MB Main Storage
8192	3192	Optional Base 1024 MB Main Storage
8193	3193	Optional Base 2048 MB Main Storage
8210	3110	Optional 64 MB Main Storage
8244	8244	PCI WS Audio Adaptor
8253	3153	Optional Base 64 MB Main Storage
8254	3154	Optional Base 128 MB Main Storage
8255	3155	Optional Base 256 MB Main Storage
8264	3164	Optional Base 512 MB Main Storage
8265	3165	Optional Base 512 MB Main Storage
8287	63A0	Optional Base 50 GB QIC Tape
8312	8312	550 1.9 GHz Proc 0/2-way
8325	8325	520 1.9 GHz Processor
8327	8327	520 1.9 GHz Processor
8330	8330	520 1.9 GHz Processor 0/2-way
8338	8338	570 2.2 GHz Processor 0/2-way
8342	6342	525 MB ¼-inch Cartridge Tape
8343	6343	1.2 GB ¼-inch Cartridge Tape
8344	6344	2.5 GB ¼-inch Cartridge Tape
8345	6345	13 GB ¼-inch Cartridge Tape
8347	6347	525 MB ¼-inch Cartridge Tape
8348	6348	1.2 GB ¼-inch Cartridge Tape
8349	6349	2.5 GB ¼-in Cartridge Tape
8410	8410	520 Base Processor Activation
8413	8413	550 Base Processor Activation
8452	8452	570 One Processor Activation
8457	8457	595 Base Processor Activation
8470	8470	570 Base 1 GB Mem Activation
8505	2630	I/O Card Unit Conversion
8606	6606	Single Disk Unit (1967 MB)
8607	6607	Optional Base DASD (4.194 GB, reg)
8609	2654	EIA 232/V.24 2-Line
8612	6602	Base 2.0 GB Dual Disk Unit
8613	6603	Base DASD Upgrade (3934 MB)
8617	6717	Optional Base 8.58 GB 10k rpm Disk
8618	6718	Optional Base 17 GB 10k rpm Disk
8650	6603	Optional Disk Unit (1.967 GB, 2 byte)
8664	2618	Optional Base Fiber DD Intf
8665	2665	Optional Base Shielded DD Intf
8706	6606	Optional Base Disk Unit (1.967 GB)
8707	6607	Optional Base Disk Unit (4.194 GB)
8713	6713	Optional Base 8.58 GB Disk Unit
8714	6714	Optional Base 17.54 GB Disk Unit
8716	6506	Optional 16 MB 1-Port FSIOP
8717	6506	Optional 32 MB 1-Port FSIOP
8718	6506	Optional 48 MB 1-Port FSIOP
8719	6506	Optional 64 MB 1-Port FSIOP
8726	6506	Optional 16 MB 2-Port FSIOP
8727	6506	Optional 32 MB 2-Port FSIOP
8728	6506	Optional 48 MB 2-Port FSIOP
8729	6506	Optional 64 MB 2-Port FSIOP
8813	6713	Optional Base 8.58 GB Disk Unit

Feat. code	CCIN	Description
8817	6717	Optional Base 8.58 GB 10k rpm Disk
8818	6718	Optional Base 17 GB 10k rpm Disk
8824	6714	Optional Base 17.54 GB Disk Unit
8863	2609	EIA 232/V.24 Two line 20E
8866	2609	EIA 232/V.24 Two line 50E
8917	6717	Optional Base 8.58 GB 10k rpm Disk
8918	6718	Optional Base 17 GB 10k rpm Disk
8924	6714	Optional Base 17.54 GB Disk Unit
8950	522A	Model 520 1-way Processor
8951	522A	Model 520 1-way Processor
8952	522A	Model 520 1-way Processor
8953	522A	Model 520 1-way Processor
8954	5228	Model 520 1-way Processor
8955	5229	Model 520 2-way Processor
8958	5237	Model 550 1/4-way Processor
8961	26EA	Model 570 0/2-way Processor
8961	26EA	Model 570 2/4-way Processor
8966	528C	595 1.9 Ghz Proc 0/16-way
8971	26F2	Model 570 2/4-way Processor
8971	26F2	Model 570 4/8-way Processor
8971	26F2	Model 570 9/12-way Processor
8971	26F2	Model 570 13/16-way Processor
8971	26F2	570 CUoD 0/2way 1/65HZ Proc
8972	522A	Model 520 1-way Processor
8981	52A4	Model 595 Processor Book
9000	7000	Panel Keylock Feature
9004	9004	South Hemisphere Designator
9020	9020	V.35 Cable 20-ft
9021	9021	X.21 Cable 20-ft
9022	9022	EIA232 20-ft Cable
9023	9023	V.24 20-ft Enhanced Cable
9024	9024	Token-Ring Cable (2.44 m)
9025	9025	Ethernet Cable AUI (3 m)
9026	9026	EIA 232 6m Client Acc cable
9027	9027	EIA 232 2.5m Clint Acc cable
9050	6050	Base Twinaxial Workstation Controller
9053	6053	Standard Twinaxial WSC Specify
9054	6054	Standard LocalTalk Controller
9079	9079	#9079 Base I/O Tower for 840 or SB3
9094	9094	Base PCI-X I/O Enclosure
9100	6100	315 MB Disk Unit Relocation
9102	6102	Standard 320 MB Disk Unit
9103	6103	Standard 400 MB Disk Unit
9104	6104	Standard 988 MB Disk Unit
9106	6105	Standard Dual Disk (640 MB)
9109	6109	Standard 988 MB Disk Unit Spec
9110	3110	Standard 64 MB Main Storage
9116	7116	High Performance CD Enable
9117	7117	Expansion Unit 1
9120	6107	Standard Dual Disk (800 MB)
9122	6122	Standard 851 MB Disk Unit (RPQ)
9126	7126	Standard Mixed Disk Enabler
9140	6140	Twinaxial Workstation Control
9141	6141	ASCII Workstation Control
9143	9143	Twinaxial Workstation Controller
9144	2637	ASCII Workstation Controller
9145	9145	Standard MFIOP/ASCII WSC
9146	2638	Standard MFIOP/Twinaxial WSC

Feat. code	CCIN	Description
9147	2637	Standard MFIOP/ASCII WSC
9148	2661	Standard MFIOP/Twinaxial WSC
9149	9149	Twinaxial passthru adapter
9150	2637	Standard MFIOP/ASCII WSC
9151	2661	Standard MFIOP/Twinaxial WSC
9152	9152	Standard MFIOP/Twinaxial WSC
9153	9153	Standard MFIOP w/o Twinaxial WSC
9156	3156	Standard 64 MB Main Storage
9159	3159	Standard 8 MB Main Storage
9160	3160	Standard 16 MB (2 SIMM)
9161	3161	Standard 32 MB Main Storage
9162	9162	Standard MFIOP w/Twinaxial WSC
9163	9163	Standard MFIOP
9164	9164	Standard MFIOP
9171	917A	Standard MFIOP/ASCII WSC
9172	2661	Twinaxial MFIOP
9173	917C	Standard MFIOP/LocalTalk WSC
9174	9174	Base Ethernet IOA
9175	9175	Base Token Ring IOA
9176	918E	Base MFIOP
9177	918D	Ethernet MFIOP
9179	3179	Base 256 MB Main Storage
9184	3184	Standard 32 MB Main Storage
9185	3185	Standard 64 MB Main Storage
9190	3190	Base 256 MB Main Storage
9211	9211	60m SPCN Optical cable
9212	9212	100m SPCN Optical cable
9215	9215	60m SPCN Copper Cable
9231	3131	Optional Base 64 MB Main Storage
9232	3132	Optional Base 128 MB Main Storage
9234	3134	Standard 128 MB Main Storage
9243	9243	400W Availability Bulk
9249	6149	Base 16/4 Mbps Token-Ring IOA
9252	3152	Standard 32 MB Main Storage
9254	3154	Standard 128 MB Main Storage
9262	3162	Standard 128 MB Main Storage
9263	3163	Standard 256 MB Main Storage
9266	3166	Standard 256 MB Main Storage
9272	3172	Standard 32 MB Main Storage
9280	6180	Base Twinaxial WSC
9282	3172	Standard 32 MB Main Storage
9284	63A0	Base 30 GB 1/4-Inch Cart Tape
9285	63A0	Base 80 GB VXA-2 Tape Drive
9299	9299	Base Enterprise Enablement
9301	9301	Upgraded 30-Disk Expansion
9304	3104	Standard 64 MB Main Storage
9313	6713	Base 8.58 GB Disk Unit
9341	6341	Standard 120 MB ¼-inch Tape
9342	6342	Standard 525 MB ¼-inch Tape
9343	6343	Standard 1.2 GB ¼-inch Tape
9347	6347	Standard 525 MB ¼-inch Tape
9348	6348	Standard 1.2 GB ¼-inch-inch Tape
9380	6380	2.5 GB ¼-inch Cart Tape
9381	6181	Base Ethernet/IEEE 802.3 IOA
9493	2793	Base PCI WAN for ECS
9494	2793	Base PCI WAN for ECS (CIM
9510	5727	Base Integrated Cache - 40 MB
9517	6517	Standard File Server 32 MB 1 Port

Feat. code	CCIN	Description
9517	28E7	Base HSL-2/RIOG Bus Adapter
9520	6320	Standard CD-ROM
9529	6529	Standard File Server 64 MB 2 Port
9548		Base 1 GB Main Storage
9549		Base 2 GB Main Storage
9553		Base 4 GB Main Storage
9570	9570	Reserved Rack Space
9584	2584	ASCII Workstation Controller
9585	2585	Twinaxial Workstation Controller
9601	6601	Standard 1.0 GB Disk Unit
9602	6602	Standard 1.0 GB Disk Unit
9605	6605	Standard 1.031 Disk Unit
9606	6606	Base 1.96 GB Disk Unit
9609	2654	Standard EIA 232/V.24 2-line
9612	2612	Standard EIA 232/V.24 1-Line/Ad
9617	2617	Base Ethernet IOP
9619	2619	Base 16/4 Mbps Token-Ring IOP
9623	2623	Standard Six Line Comm Controller
9624	2624	Store Device Control Spec
9651	2651	Storage Device Controller
9652	6602	Standard Disk Unit (1.031 GB, 2 byte)
9653	63A0	Base 30 GB ¼-inch Tape
9673	2673	Standard Optical Bus Adapter
9691	2691	#9691 Base Bus Adapter HSL Copper
9696	2696	Base Optical Bus Adapter
9699	2699	Base 2-Line WAN IOA
9705	6605	Standard 1.031 Disk Unit regulated
9707	6607	Base 4.19 GB Disk Unit
9720	2720	Base PCI WAN/Twinaxial IOA
9721	2721	Base PCI 2-Line WAN IOA
9723	2723	Base Ethernet IOA
9724	2724	Base 16/4 Mbps Token-Ring IOA
9726	0446	Base 512 MB Server Memory
9728	2728	Base PCI Disk Unit Controller
9730	273B	Base HSL-2 Ports - 4 Copper
9732	2732	Base HSL Ports - 8 Copper
9733	2732	Base HSL Ports - 8 Copper
9737	2737	Base HSL Ports - 16 Copper
9738	2838	Base PCI 100/10 Mbps Ethernet
9739	2739	Base Optical Bus Adapter
9739	9739	Base Optical Bus Adapter
9740	2740	Base PCI RAID Disk Unit Controller
9745	2745	Base PCI 2-Line WAN IOA
9746	2746	Base PCI Twinaxial Workstation IOA
9748	2748	Base PCI Disk Unit Controller
9749	2849	Base PCI 100/10 Ethernet IOA
9751	6751	Base MFIOP with RAID
9752	2754	Base HSL Ports - 8 Copper
9753	6753	Base MFIOP
9754	6754	Base MFIOP with RAID
9755	2755	Base HSL Ports -16 Copper
9758	2758	Base HSL Ports - 2 Optical/6 Cop
9759	2759	Base HSL Ports-4 Optical/12 Cop
9767	2767	Base PCI Disk Unit Controller
9771	2771	Base PCI 2-Line WAN w/Modem
9774	2758	Base HSL Ports - 2 Optical/6 Cop
9777	2754	Base HSL Ports - 8 Copper
9778	2778	Base PCI RAID Disk Unit Controller

Feat. code	CCIN	Description
9785	2785	Base HSL-2 Ports - 2 Copper
9786	2786	Base HSL Ports - 2 Optical
9787	28B3	Base HSL-2 Ports - 2 Copper
9789	2789	Base HSL Ports - 4 Optical
9792	2892	Base PCI Integ xSeries Server
9793	2793	Base PCI 2-Line WAN w/Modem
9794	2793	Base PCI 2-Line WAN w/Modem
9800	2800	Internal Disk Unit (640 MB)
9801	2801	Internal Disk Unit (1 GB)
9802	2802	Standard 2.0 GB Int Disk Unit
9803	9803	2.5m DFCI cable
9814	9814	20-ft Antenna Cable Wireless
9815	9815	50-ft Antenna Cable Wireless
9820	9820	2nd Bus cable for Model 300
9835	9835	V.24 Cable 50-ft Enhanced
9836	9836	EIA232 Cable 50-ft
9838	9838	V.35 Cable 50-ft
9839	9839	X.21 Cable 50-ft
9844	2844	Base PCI IOP
9853	9853	20.0m optical bus cable
9854	9854	60m optical bus cable
9855	9865	100.0 M optical bus cable
9862	6152	EIA 232/V.24 1-Line 20E
9865	6152	EIA 232/V.24 1-Line 50E
9876	9876	Base Optical Bus Adapter
9877	9877	Base HSL-2 Bus Adapter
9879	9879	20-ft/6m V.35 Cable
9880	9880	80-ft/24.4m V.35 Cable
9882	9882	20-ft/6m V.36 Cable
9883	9883	80-ft/24.4m V.36 Cable
9884	9884	150-ft/45.7m V.36 Cable
9885	9885	20-ft/6m X.21 Cable
9886	2886	Base Optical Bus Adapter
9887	2887	Base HSL-2 Bus Adapter
9904	4104	4 MB Main Storage
9907	6607	Base 4.19 GB Disk Unit
9927	9927	Channel Box and cable
9928	9928	1.7m attach cable
9929	9929	6.6m attach cable
9930	9930	24.0m attach cable
9943	2843	Base PCI IOP
9980	9980	Serpentine Cable Connector



Software for the System i5, eServer i5, and iSeries models

This chapter covers i5/OS V5R4, V5R3 and earlier versions of OS/400 that support Reduced Instruction Set Computing (RISC)-based processors on the RISC, POWER4, POWER5, and POWER5+ processors.

Note 1: IBM i5/OS Version 5 Release 4 and Version 5 Release 3 are the releases currently supported for the System i5 and eServer i5, or iSeries servers. These i5/OS releases are required when using POWER5 or POWER5+ processors.

Note 2: RISC processor-based models of the iSeries and AS/400e servers are 800, 810, 820, 830, 840, 270, SB2, SB3, 250, 720, 730, 740, 150, 620, 630, 640, 50S, 53S, 500, 510, 530, 4x0, and Sx0. POWER4 is the chip technology used in the Model 825, 870, and 890. POWER5 is the chip technology used in the Models 520, 550, 570, and 595. And POWER5+ is the chip technology used in the Models 520, 550, and 570.

OS/400 software releases up to and including V3R2 run only on CISC models of the AS/400 system (Models Bx0, Cx0, Dx0, Exx, Fx0, P0x, 100, 135, 140, 2x0, and 3x0). For information about software supporting these CISC systems, refer to *AS/400 CISC System Builder*, REDP-0042. CISC model capacity summary tables are in: Chapter 12, "Summary of AS/400 CISC models" on page 389.

OS/400 software releases from V3R6 and V3R7 through V5R2 run on AS/400e systems (Models 150, 4xx, 5xx, and 6xx). For information about software supporting these RISC systems, refer to *IBM eServer AS/400e RISC System Builder Version 3 Release 6 - Version 5 Release 2*, REDP-0342. RISC model capacity summary tables are in: Chapter 13, "Summary of AS/400e RISC models" on page 407.

10.1 Minimum i5/OS and OS/400 software level requirements for System i5, eServer i5, and iSeries hardware

The following tables identify the minimum operating system software release required for IBM System i5, IBM eServer i5, and iSeries models. The i5 550 models, for example, have a minimum release of i5/OS of V5R3.

Features supported in these processors might be supported by earlier releases of i5/OS or OS/400 than the processor itself. Many of the feature codes that are supported in these processors are also represented in this chapter.

OS/400 V5R1	OS/400 V5R2
9406-270 #2431, #2432, #2434 Processors 9406-270 #2452, #2454 DSD Processors 9406-820 #0150, #0151, #0152, #2435, #2436, #2437, #2438 Processors 9406-820 #2456, #2457, #2458 DSD Processors 9406-830 #0153, #2349, #2351 Processors 9406-840 #0158, #0159, #2461 Processors 9406-8x0 #235x CUoD #037x LC-SC Adapter Kit #1422 PDU Line Cord #147X Optical HSL Cable #1548 Interactive Capacity Card #2739 Optical Bus Adapter #275x HSL Ports #2760 PCI 1 Gbps Ethernet UTP Adapter #2765 PCI Fibre Channel Tape Controller #2766 PCI Fibre Channel Disk Controller #2772 PCI Dual WAN/Modem IOA #2773 PCI Dual WAN/Modem IOA (ANSI) #2777 HSL Ports - 8 Copper - 8 Copper #2778 PCI RAID Disk Unit Controller #2799 PCI Integrated xSeries Server #2805 PCI Quad Modem IOA #2806 PCI Quad Modem (CIM) #2817 PCI 155 Mbps MMF ATM IOA #2899 PCI Integrated xSeries Server #3007 1 GB main storage #3009 128 MB main storage #3027 1 GB main storage #3029 128 MB main storage #3032 256 MB main storage #3033 512 MB main storage #3034 1 GB main storage #3067 1 GB main storage #4319 35.16 GB 10k RPM Disk Unit #4585 80 GB VXA-2 Tape Device #4487 50 GB ¼-inch Cartridge Tape Device #4587 50 GB ¼-inch Cartridge Tape Device #4685 80 GB VXA-2 Tape Device #4687 50 GB ¼-inch Cartridge Tape Device #4778 PCI RAID Disk Unit Controller #5078 PCI Expansion Unit #510x PCI Disk Expansion Unit #516x Power Dist Unit #9002 Dual Line Cord Enabler #9752 Base HSL Ports - 8 Copper #9755 Base HSL Ports - 16 Copper #9777 Base HSL Ports - 8 Copper #9778 Base PCI RAID Disk Unit Controller 7207-330 External SLR60 Tape Drive	9406-800 #2463, #2464 Processors 9406-810 #2465, #2466, #2467, #2469 Processors 9406-825 #2473, #2495 Processors 9406-870 #2486, #2489, #2496 Processors 9406-890 #0197, #0198, #2487, #2488, #2497, #2498, #2499 Processors #0595 PCI-X Expansion Unit in Rack #15xx Interactive Card #2742 Two-Line WAN IOA #2757 PCI-X Ultra RAID Disk Controller #2776 HSL-2 Ports - 8 Copper #2782 PCI-X RAID Disk Unit Controller #2785 HSL-2 Ports - 2 Copper #2786 HSL Ports - 2 Optical #2787 PCI-X Fibre Channel Disk Controller #2788 HSL Ports - 8 Optical #2792 PCI Integrated xSeries Server #2793/#9793 Two-Line WAN IOA with Modem #2794/#9794 Two-Line IOA with Modem #2844 PCI IOP #2849 10/100 Mbps Ethernet Adapter #2892 PCI Integrated xSeries Server #2886 Optical Bus Adapter #3015 8 GB main storage #3016 8 GB main storage #3017 32 GB main storage #3018 32 GB main storage #3020 4 GB main storage #3021 4 GB main storage #3035 16 GB main storage #3036 16 GB main storage #3042 256 MB main storage #3043 512 MB main storage #3044 1024 MB main storage #3046 2048 MB main storage #3092 256 MB main storage #3093 512 MB main storage #3094 1024 MB main storage #3096 2048 MB main storage #4326 35.16 GB 15k RPM Disk Unit #4327 70.56 GB 15k RPM Disk Unit #4531 DVD-ROM #4631 DVD-ROM #4710 PCI Integrated xSeries Server #4805 PCI Cryptographic Accelerator #4810 PCI Integrated xSeries Server #5088 PCI-X Expansion Unit #5094 PCI-X Expansion Tower #5095 PCI-X Expansion Tower #5108 PCI-X Expansion Unit #5115 Dual Line Cords Tower #5116 Dual Line Cords #5294 Tower #5138 Redundant Power and Cooling #5294 1.8m I/O Tower #5580 - #2780 Controller with Auxiliary Write Cache #5581 - #2757 Controller with Auxiliary Write Cache #5700 PCI 1 Gbps Ethernet IOAI #5701 PCI 1 Gbps Ethernet UTP IOA

OS/400 V5R1	OS/400 V5R2
	(cont.) #5702 PCI-X Ultra Tape Controller #5703 PCI-X RAID Disk Unit Controller #5704 PCI-X Fibre Channel Tape Controller #5705 PCI-X Tape/DASD Controller #7116 System Unit Expansion #7124 DASD Expansion Unit - 5 slot #7136 DASD Expansion Unit - 6 slot #7137 DASD Concurrent Maintenance #8094 Optional 1.8 m I/O Rack #9094 Base PCI I/O Enclosure #9492 Base PCI Integrated xSeries Server #9710 Base PCI Integrated xSeries Server #9746 Base PCI Twinaxial IOA #9749 Base PCI 100/10 Ethernet IOA #9792 Base PCI Integrated xSeries Server #9844 Base PCI IOP

i5/OS V5R3 with V5R3M5 LIC	i5/OS V5R4
#9406-520 #8325, #8327, #8330 Processors #0906 1-way Server Feature #2888 RIO-G Ports - 2 Copper #4400 1GB DDR2 Main Storage #4474 2GB DDR2 Main Storage #4475 4GB DDR2 Main Storage #4477 8GB DDR2 Main Storage #5159 850 Watt Power Supply #5553 System Console Ethernet w/o IOP #5776 PCI-X Disk Controller 90MB without IOP #6803 PCI WAN for ECS #6804 PCI WAN for ECS (CIM) #7256 520 Enterprise Enablement #7320 520 One Processor Activation #7350 Value Edition for #0975 #7352 Value Edition for #0975 #7355 Accelerator for System i5 #7357 Accelerator for System i5 #7366 Solution Edition for #0906 #7373 High Availability Edition for #0906 #7374 High Availability Edition for #0906 #7620 520 On/Off Processor Enablement #7622 520 Reserve Capacity Prepaid #7734 Enterprise Edition for #0906 #7735 Enterprise Edition for #0906 #7736 Enterprise Edition for #0906 #7784 Standard Edition for #0906 #7785 Standard Edition for #0906 #8410 520 Base Processor Activation #9299 Base Enterprise Enablement for 520	#0047 Device Parity RAID-6 All #0532 i5/OS V5R4, V5R4M0 LIC #5557 System Console Ethernet w/o IOP#0047 Device Parity RAID-6 All, #6800 PCI 1Gbps Ethernet IOA #6801 PCI 1Gbps Ethernet UTP IOA #6803 PCI WAN for ECS #6804 PCI WAN for ECS (CIM)

Note: You can verify this information by using the Offering Information (OITool), IBMLink™, or other online tools. You can find the OITool on the Web at:

<http://w3-3.ibm.com/sales/ssi/>

10.2 i5/OS and OS/400 general availability and support

The following table shows the availability, withdrawal, and end of support dates for each release of the operating system. Note that i5/OS V5R4, V5R3, and OS/400 V5R2 are the supported levels of operating system for the System i models. All earlier releases of OS/400 are withdrawn from IBM marketing and support.

Release	General availability	Withdrawn from marketing	End of program support
R7.5 SSP	08 March 1996	09 February 1999	31 May 2000
V3R0.5	03 June 1994	11 February 1997	31 May 1997
V3R1	30 June 1995	11 February 1997	31 October 1998
V3R2	21 June 1996	10 February 1998	31 May 2000
V3R6	29 September 1995	19 August 1997	31 October 1998
V3R7	09 November 1996	01 September 1998	30 June 1999
V4R1	29 August 1997	09 February 1999	31 May 2000
V4R2	27 February 1998	09 February 1999	31 May 2000
V4R3	11 September 1998	15 February 2000	31 January 2001
V4R4	21 May 1999	31 May 2001	31 May 2001
V4R5	28 July 2000	2 July 2002	31 December 2002
V5R1	25 May 2001	21 November 2003	30 September 2005
V5R2	30 August 2002	01 October 2005	30 April 2007
V5R3	28 May 2004	---	---
V5R4	14 February 2006	---	---

10.3 i5/OS and OS/400 upgrade paths

The following table shows the valid upgrade paths for i5/OS and OS/400.

To: From:	V4R2 **	V4R3 **	V4R4 **	V4R5 **	V5R1 **	V5R2	i5/OS V5R3	i5/OS V5R4
V4R1	X	X	X	X	-	-	-	-
V4R2	-	X	X	X	-	-	-	-
V4R3	-	-	X	X	-	-	-	-
V4R4	-	-	-	X	X	-	-	-
V4R5	-	-	-	-	X	X	-	-
V5R1	-	-	-	-	-	X	X	-
V5R2	-	-	-	-	-	-	X	X
V5R3	-	-	-	-	-	-	-	X

* OS/400 V4R5 is the last release to offer single-step CISC-to-RISC upgrade capabilities from V3R2.
 ** Withdrawn from IBM support.

Refer to the appropriate software installation manual for instructions to upgrade software. Single step RISC-to-RISC upgrades are supported as normal upgrade procedures.

10.4 Current-release to previous-release support for i5/OS and OS/400

The Target Release (TGTRLS) parameter specifies the valid i5/OS or OS/400 release of the operating system on which you intend to restore and use the object.

Values for TGTRLS parameter			
Current i5/OS or OS/400 release	*CURRENT	*PRV	Other valid values
V5R4	V5R4	V5R3	V5R2
V5R3	V5R3	V5R2	V5R1
V5R2	V5R2	V5R1	V4R5
V5R1	V5R1	V4R5	V4R4
V4R5	V4R5	V4R4	V4R3 V4R2 V3R2

10.5 Software ordering terminology

This section explains the standard terminology for software. The terms used for all software versions are:

- ▶ **Product identifier:** All IBM Licensed Programs including i5/OS and OS/400 have a product identifier. The format is 57xx-yyy. For example, i5/OS V5R4 is 5722-SS1.
- ▶ **HIPO:** New, preload orders of Version 5 are defined with HIPO numbers associated with the hardware product order. For example, HIPO feature 5372-IS5 is for new orders of Version 5. The 5372-IS5 contains features, each feature indicating the software product to be loaded. For example, #1002 indicates BRMS (5722-BR1). It serves as an (administrative) software preload ordering vehicle. The term HIPO is not an acronym.
- ▶ **Additional feature:** Additional features are product and associated HIPO features that relate to an optional feature of a licensed program. The additional feature provides the delivery mechanism for the licensed program.
- ▶ **Skip ship:** For Version 5, some products have a “skip ship” from a previous release. They retain their original product identifiers, but can still be ordered.

10.6 i5/OS V5R4 software

The following tables show the V5R4 i5/OS-based software products that are most commonly ordered. It is not a definitive list of all iSeries software products now available.

See 10.10, “Notes for Version 5 software tables” on page 366, for Version 5 software group information.

Operating system and base products	Skip ship ²	Product identifier	HIPO feature (5372-IS5) ²	Keyed stamped media ⁹	Software Maintenance Delivery ⁸
Operating System/400® ^{6,7}	---	5722-SS1	1000	5050	S
Media and Storage Extensions	---	5722-SS1 Option 18	1500	5103	S
OptiConnect for OS/400	---	5722-SS1 Option 23	1515		S

DB2® Symmetric Multiprocessing	---	5722-SS1 Option 26	1517		S
DB2 MultiSystem	---	5722-SS1 Option 27	1518		S
Print Services Facility™ (PSF/400) 1-45 IPM 1-100 IPM Any speed	---	5722-SS1 Option 36 Option 37 Option 38	1501 1502 1503	5112 5113 5114	S
High Availability Switchable Resource	---	5722-SS1 Option 41	1505	5116	S
High Availability Journal Performance	---	5722-SS1 Option 42	1545	5117	S
S/38 Utilities for AS/400 ⁶	✓	5722-DB1	1021		S
HTTP Server for iSeries	---	5722-DG1	---		S
IBM Toolbox for Java™	---	5722-JC1	---		S
IBM Developer Kit for Java	---	5722-JV1	---		S
DB2 Query Manager and SQL Development Kit for iSeries ^{6, 7}	---	5722-ST1	1011	5050	S
iSeries Access for Windows	---	5722-XE1	---		S

OS/400 complementary database software	Skip ship ²	Product identifier	HIPO feature (5372-IS5) ²	Keyed stamped media ⁹	Software Maintenance Delivery ⁸
DB2 OLAP Server™ for iSeries V8.1 ¹⁰	---	5724-B78	---		
DB2 UDB Warehouse Manager Standard Edition V8	✓	5724-E66			
DB2 Universal Database™ Extenders for iSeries V7.2	---	5722-DE1	1004	5050	S
DB2 DataPropagator™ for iSeries Version 8.1	✓	5722-DP4	1035	5050	S
DB2 QMF™ Distributed Edition V8.1 for Multiplatforms	---	5724-E86			
i5/OS Integration for Linux on xSeries	---	5722-LSV	---		
Query for iSeries ^{6, 7}	---	5722-QU1	1009	5050	S
System Openness Includes	---	5722-SS1 Option 13	---		S
NetWare Enhanced Integration	---	5722-SS1 Option 25	---		S
Portable Application Solution Environment	---	5722-SS1 Option 33	---		S
TCP/IP Connectivity Utilities for iSeries	---	5722-TC1	---		S
iSeries Access for Linux	✓	5722-XL1			
iSeries Access for Web	---	5722-XH2			
iSeries Access for Wireless	---	5722-XP1			S
iSeries Access Family ^{6,7}	---	5722-XW1	1012 Client Processor - 1013 Client User	5050	S

Networking products	Skip ship ²	Product identifier	HIPO feature ² (5372-IS5)	Keyed stamped media ⁹	Software subscription or maintenance ⁸
Host On-Demand Version 6.0	P	5733-A59	---		M
WebSphere® MQ Version 5.3 ⁶	P	5733-B41	---	-	M
Communications Utilities for iSeries ⁶	---	5722-CM1	1003	5050	S
Cryptographic Support for AS/400 ⁶	✓	5722-CR1	1020		S
iSeries Cryptographic Device Manager		5733-CY1			
Communications Server for Windows NT Version 6.1	P	5639-F25	---		---
Network Authentication Enablement for i5/OS		5722-NAE			
NetView® FTP		5798-TBG			
* Ordering ID					

WebSphere and on demand business products	Skip ship ²	Product identifier	HIPO features ²	Keyed stamped media ⁹	Software subscription or maintenance ⁸
IBM Business Solutions	✓	5722-BZ1			M
WebSphere Application Server Version 6.0 Developer Edition for iSeries		5724-H89			M
WebSphere Application Server Express V5.1 iSeries	✓	5722-E51	6007		M
WebSphere Commerce for iSeries V5.6, Business Edition, Professional Edition, and Express		5724-I38 5724-I40 5724-I36	---		M
Software Integration Assistant for iSeries		5722-IA1			
WebSphere Application Server Version 5.1 for iSeries		5733-W51			M
WebSphere Application Server 6.0		5733-W60			
WebSphere Enablement	✓	5733-WE2			M

Systems management products	Skip ship ²	Product identifier	HIPO feature ²	Keyed stamped media ⁹	Software subscription or maintenance ⁸
Backup Recovery and Media Services for iSeries ⁶ Network Feature Advanced Feature	---	5722-BR1	1002 1506 1507	5050 5101 5102	S
Director with VE Console for i5/OS V5.10	New	5733-DR1			Product Code
VE Enterprise Workload Manager for i5/OS V2.1	New	5733-EWA			Product Code
PATROL for iSeries – Predict	---	5620-FIF	---		S
Tivoli® Storage Manager Enterprise Edition V5.1	---	5698-ISE	---		---
Tivoli Storage Manager V5.1	---	5698-ISM	---		---
Advanced Job Scheduler for iSeries ⁶	---	5722-JS1	1007	5050	S
Tivoli Management Agent	---	1TME-LCF	---		---

Managed System Services for iSeries ⁶	---	5722-MG1	1030		S
Performance Tools for iSeries ^{6,7} Manager Feature Agent Feature	---	5722-PT1 Option 1 Option2	1008 1508 1509	5050 5101 5102	S
Content Manager OnDemand for iSeries ⁶ PDF Indexer Feature Web Enablement Kit Feature	---	5722-RD1 Option 12 Option 11	1010 1510 1511		M
VE Resource Dependency Service V2.1	New	5733-RDS			Product Code
System Manager for iSeries ⁶	---	5722-SM1	1032		S

Application development products	Skip ship ²	Product identifier	HIPO feature ²	Keyed stamped media ⁹	Software subscription or maintenance ⁸
CICS® Transaction Server for iSeries ⁶	---	5722-DFH	1025		S
WebSphere Application Server Version 6.0 Developer Edition for iSeries		5724-H89			M
Portable Utilities		5733-SC1			
WebSphere Development Studio (Toolset)	---	5722-WDS	1015	5050	S
XML Toolkit for iSeries	✓	5733-XT1	---		S

Office support and printing products	Skip ship ²	Product identifier	HIPO feature ²	Keyed stamped media ⁹	Software subscription or maintenance ⁸
Advanced Function Printing™ Utilities for AS/400 ⁶	✓	5722-AF1	1001	5050	S
Advanced DBCS Printer Support for AS/400 ⁶	✓	5722-AP1	1014	5050	S
AFP™ Font Collection for Workstation and OS/400	✓	5648-B45	---		
Business Graphics Utility for AS/400 ⁶	✓	5722-DS1	1027		S
Facsimile Support for iSeries	✓	5798-FAX	---		S
Advanced Function Printing Fonts for AS/400 ⁶ Font Options	✓	5769-FNT Options 1-15	--- 1520-1534		S
Advanced Function Printing DBCS Fonts for AS/400 ^{6†} Font Options	✓	5769-FN1	--- 1535-1539		S
Domino Fax for iSeries	✓	5733-FXD	---		S
Infoprint® Fonts for Multiplatform	✓	5648-E77			
Infoprint Designer for iSeries	✓	5733-ID1	6003		S
Infoprint Server for iSeries	---	5722-IP1	1006	5050	S
Lotus® Domino for iSeries Version 6.0	P	5733-LD7	---		M
Lotus Domino 6.5 for iSeries	P	5733--L65	---		M
QuickPlace® for iSeries Version 2.0	P	5733-LQP	---		M
Content Manager for iSeries	P	5722-VI1	1034		M

Object Server		Option 1	---		
Advanced Workflow		Option 4	---		

Additional and packaged products	Skip ship ²	Product identifier	HIPO feature ²	Keyed stamped media ⁹	Software subscription or maintenance ⁸
Host Access Client Package for iSeries, Version 5.0 Personal Communications V5.8 WebSphere Host On-Demand V9.0		5724-I21	---		
Host Access Client Package for Multiplatforms, Version 5.0 Personal Communications V5.8 WebSphere Host On-Demand V9.0		5724-I20	---		
ValuPak for V5R3: 5722-SS1: 1-45 ipm feature 5722-XW1: iSeries Access 5722-QU1: Query 400 5722-ST1: DB2/400 Query Manager and SQL Development Kit 5722-PT1: Performance Tools (Manager feature)		5722-VP1	---		

10.7 i5/OS V5R3 software

The following tables show the V5R3 i5/OS-based software products that are most commonly ordered. It is not a definitive list of all iSeries software products now available.

See 10.10, “Notes for Version 5 software tables” on page 366, for Version 5 software group information.

Operating system and base products	Skip ship ²	Product identifier	HIPO feature (5372-IS5) ²	Keyed stamped media ⁹	Software subscription or maintenance ⁸
Operating System/400 ^{6,7}	---	5722-SS1	1000	5050	S
Media and Storage Extensions	---	5722-SS1 Option 18	1500	5103	S
OptiConnect for OS/400	---	5722-SS1 Option 23	1515		S
DB2 Symmetric Multiprocessing	---	5722-SS1 Option 26	1517		S
DB2 MultiSystem	---	5722-SS1 Option 27	1518		S
Print Services Facility (PSF/400) 1-45 IPM 1-100 IPM Any speed	---	5722-SS1 Option 36 Option 37 Option 38	1501 1502 1503	5112 5113 5114	S
High Availability Switchable Resource	---	5722-SS1 Option 41	1505	5116	S
High Availability Journal Performance	---	5722-SS1 Option 42	1545	5117	S

IBM Business Solutions	New	5722-BZ1			M
HTTP Server for iSeries	---	5722-DG1	---		S
iSeries Enterprise Edition Installation Edition	---	5733-ED1			-
Software Integration Assistant for iSeries	✓	5722-IA1			S
IBM Toolbox for Java	---	5722-JC1	---		S
IBM Developer Kit for Java	✓	5722-JV1	---		S
Tivoli Management Agent	---	1TME-LCF	---		---
TCP/IP Connectivity Utilities for iSeries	---	5722-TC1	---		S
iSeries Access for Windows	---	5722-XE1	---		S
iSeries Integration for Windows Server	---	5722-WSV	---		S

OS/400 complementary database software	Skip ship ²	Product identifier	HIPO feature (5372-IS5) ²	Keyed stamped media ⁹	Software subscription or maintenance ⁸
DB2 Warehouse Manager V8	P	5724-B08			
DB2 Universal Database Extenders for iSeries V7.2	---	5722-DE1	1004	5050	S
DB2 DataPropagator for iSeries Version 8.1	✓	5722-DP4	1035	5050	S
DB2 QMF Distributed Edition V8.1 for Multiplatforms	New	5724-E86			
DB2 Table Editor for iSeries Version 4.3	P	5697-G84	---		S
DB2 Web Query Tool for iSeries Version 1.3	P	5697-G85	---		S
DB2 OLAP Server for iSeries V8.1 ¹⁰	---	5724-B78	---		
DB2 Spatial Extender Version 8	New	5765-F40			
DB2 UDB Workgroup Server Edition	New	5733-LD1			
Query for iSeries ^{6, 7}	---	5722-QU1	1009	5050	S
System Openness Includes	---	5722-SS1 Option 13	---		S
NetWare Enhanced Integration	---	5722-SS1 Option 25	---		S
Portable Application Solution Environment	---	5722-SS1 Option 33	---		S
iSeries Access for Web	---	5722-XH2			S
iSeries Access for Linux	New	5722-XL1			-
iSeries Access for Wireless	New	5722-XP1			S
iSeries Access Family ^{6,7}	---	5722-XW1	1012 Client Processor - 1013 Client User	5050	S

Networking products	Skip ship ²	Product identifier	HIPO feature ² (5372-IS5)	Keyed stamped media ⁹	Software subscription or maintenance ⁸
Cryptographic Access Provider 128-bit ⁶	---	5722-AC3	1017		S
MQSeries® for iSeries Version 5.3 ⁶	P	5724-B41	---	-	M
iSeries Client Encryption (128-bit) ⁶	---	5722-CE3	1019		S
Communications Utilities for iSeries ⁶	---	5722-CM1	1003	5050	S
Cryptographic Support for AS/400 ⁶	✓	5722-CR1	1020		S
iSeries Cryptographic Device Manager	New	5733-CY1			Y
Portable Utilities for i5/OS	New	5733-SC1	---		---
Communications Server for Windows NT Version 6.1	P	5639-F25	---		---
NetView FTP	✓	5798-TBG			---

WebSphere and on demand business products	Skip ship ²	Product identifier	HIPO features ²	Keyed stamped media ⁹	Software subscription or maintenance ⁸
Connect for iSeries V2 ¹⁰	P	5733-CO2	---		S
WebSphere Application Server Version 5.1 Developer Edition for iSeries ¹⁰	P	5724-D18			M
WebSphere Application Server - Express V5.1 for iSeries	P	5722-E51			M
Grid Toolbox V3 for OS/400	New	5733-GT1			M
WebSphere Commerce Payments for iSeries V5.5	---	5733-PYS			S
WebSphere Application Server - Express V5.0 for iSeries and Express V5.1 for iSeries	P	5722-IWE 5722-E51	6007		M
WebSphere Advanced Edition V4.0.1 ⁶	P	5733-WA4			M
WebSphere Commerce for iSeries V5.5	P	5733-WC5			M
WebSphere Advanced Edition Single Server V4.0.1	P	5733-WS4			M
WebSphere Application Server Version 5.0 for iSeries	P	5733-WS5			M
WebSphere Application Server Version 5.1 for iSeries	P	5733-W51			M
WebSphere Application Server Version 6	P	5733-W60			M
WebSphere Enablement	New	5733-WE1	6007		M
Web Enablement for i5/OS	New	5733-WE2			M

Systems management products	Skip ship ²	Product identifier	HIPO feature ²	Keyed stamped media ⁹	Software subscription or maintenance ⁸
Backup Recovery and Media Services for iSeries ⁶ Network Feature Advanced Feature	---	5722-BR1	1002 1506 1507	5050 5102	S

Director with VE Console for i5/OS V5.10	New	5733-DR1			M
VE Enterprise Workload Manager for i5/OS V2.1	New	5733-EWA			M
PATROL for iSeries – Predict	---	5620-FIF	---		S
Tivoli Storage Manager Enterprise Edition V5.1	P	5698-ISE	---		---
Tivoli Storage Manager V5.1	---	5698-ISM	---		---
Advanced Job Scheduler for iSeries ⁶	---	5722-JS1	1007	5050	S
Managed System Services for iSeries ⁶	---	5722-MG1	1030		S
Performance Tools for iSeries ^{6,7} Manager Feature Agent Feature	---	5722-PT1 Option 1 Option2	1008 1508 1509	5050 5101 5102	S
Content Manager OnDemand for iSeries ⁶ PDF Indexer Feature Web Enablement Kit Feature	---	5722-RD1 Option 12 Option 11	1010 1510 1511		M
VE Resource Dependency Service V2.1	New	5722-RDS			M
System Manager for iSeries ⁶	---	5722-SM1	1032		S

Application development products	Skip ship ²	Product identifier	HIPO feature ²	Keyed stamped media ⁹	Software subscription or maintenance ⁸
WebSphere Commerce for iSeries V5.6, Business Edition, Professional Edition, and Express		5724-I38 5724-I40 5724-I36	---		M
S/38 Utilities for AS/400 ⁶	---	5722-DB1	1021		S
CICS Transaction Server for iSeries ⁶	---	5722-DFH	1025		S
Application Program Driver	✓	5722-PD1	1031		S
DB2 Query Manager and SQL Development Kit for iSeries ^{6,7}	---	5722-ST1	1011	5050	S
Visualage Generator Server for iSeries	✓	5769-VG1	1033		S
WebSphere Development Studio (Toolset)	---	5722-WDS	1015	5050	S
XML Toolkit for iSeries	---	5733-XT1	---		S

Office support and printing products	Skip ship ²	Product identifier	HIPO feature ²	Keyed stamped media ⁹	Software subscription or maintenance ⁸
Advanced Function Printing Utilities for AS/400 ⁶	✓	5722-AF1	1001	5050	S
Advanced DBCS Printer Support for AS/400 ⁶	---	5722-AP1	1014	5050	S
AFP Font Collection for Workstation and OS/400	✓	5648-B45	---		
Business Graphics Utility for AS/400 ⁶	---	5722-DS1	1027		S
InfoPrint Fonts for Multiplatforms ⁵	New	5648-E77			-
Content Manager for iSeries V8.2	---	5724-F73			M
Facsimile Support for iSeries	✓	5798-FAX	---		S
Advanced Function Printing Fonts for AS/400 ⁶	✓	5769-FNT	---		S

Font Options		Options 1-15	1520-1534		
Advanced Function Printing DBCS Fonts for AS/400 ^{6†} Font Options	✓	5769-FN1	---		S
			1535-1539		
Domino Fax for iSeries	✓	5733-FXD	---		S
Infoprint Designer for iSeries	✓	5733-ID1	6003		S
Infoprint Server for iSeries	---	5722-IP1	1006	5050	S
Content Manager for iSeries	P	5722-VI1	1034		M
Object Server		Option 1	---		
Advanced Workflow		Option 4	---		

Additional and packaged products	Skip ship ²	Product identifier	HIPO feature ²	Keyed stamped media ⁹	Software subscription or maintenance ⁸
Host Access Client Package for iSeries, Version 4.0 Personal Communications V5.7 WebSphere Host On-Demand V8.0		5724-F68	---		
Host Access Client Package for multiplatforms, Version 4.0 Personal Communications V5.7 WebSphere Host On-Demand V8.0		5724-F69	---		
Lotus Domino 7		5733-LD7			M
Lotus Enterprise Integrator® for iSeries ⁶	---	5769-LNP	---		M
ValuPak for V5R3: 5722-SS1: OS/400 5722-SS1: 1-45 ipm feature 5722-XW1: Client Access Family/iSeries Access 5722-QU1: Query 400 5722-ST1: DB2/400 Query Manager and SQL Development Kit 5722-PT1: Performance Tools (Manager feature)		5722-VP1	---		

10.8 OS/400 V5R2 software

The following tables show the V5R2 OS/400-based software products that are most commonly ordered. It is not a definitive list of all iSeries software products now available.

See 10.10, “Notes for Version 5 software tables” on page 366, for Version 5 software group information.

Operating system and base products	Skip ship ²	Product identifier	HIPO feature (5372-IS5) ²	Keyed stamped media ⁹	Software subscription or maintenance ⁸
Operating System/400 ^{6,7}	---	5722-SS1	1000	5050	S
Media and Storage Extensions	---	5722-SS1 Option 18	1500	5103	S
OptiConnect for OS/400	---	5722-SS1 Option 23	1515		S

Operating system and base products	Skip ship ²	Product identifier	HIPO feature (5372-IS5) ²	Keyed stamped media ⁹	Software subscription or maintenance ⁸
DB2 Symmetric Multiprocessing	---	5722-SS1 Option 26	1517		S
DB2 MultiSystem	---	5722-SS1 Option 27	1518		S
Print Services Facility (PSF/400) 1-45 IPM 1-100 IPM Any speed	---	5722-SS1 Option 36 Option 37 Option 38	1501 1502 1503	5112 5113 5114	S
High Availability Switchable Resource	---	5722-SS1 Option 41	1505	5116	S
High Availability Journal Performance	---	5722-SS1 Option 42	1545	5117	S
S/38 Utilities for AS/400 ⁶	---	5722-DB1	1021		S
HTTP Server for iSeries	---	5722-DG1	---		S
IBM Toolbox for Java	---	5722-JC1	---		S
IBM Developer Kit for Java	---	5722-JV1	---		S
DB2 Query Manager and SQL Development Kit for iSeries ^{6, 7}	---	5722-ST1	1011	5050	S
iSeries Integration for Windows Server	---	5722-WSV	---		S

OS/400 complementary database software	Skip ship ²	Product identifier	HIPO feature (5372-IS5) ²	Keyed stamped media ⁹	Software subscription or maintenance ⁸
Warehouse Manager for iSeries	P	5724-B08			
DCE Base Services	P	5769-DC1	1023		S
DCE DES Library Routines	P	5769-DC3	1024		S
DB2 Universal Database Extenders for iSeries V7.2	---	5722-DE1	1004	5050	S
DB2 DataPropagator for iSeries Version 8.1	New	5722-DP4	1035	5050	S
DB2 QMF Distributed Edition V8.1 for Multiplatforms	New	5724-E86			
QMF for Windows for iSeries Version 7.2	P	5697-G24	---		S
DB2 Table Editor for iSeries Version 4.3	P	5697-G84	---		S
DB2 Web Query Tool for iSeries Version 1.3	P	5697-G85	---		S
DB2 Intelligent Miner™ for Data V6.1	P	5733-IM3	---		M
iSeries ODBC Driver for Linux	---	5733-LO1	---		S
DB2 OLAP Server for iSeries V7.1	---	5686-OLP	---		
Query for iSeries ^{6, 7}	---	5722-QU1	1009	5050	S
Electronic Service Agent™ for iSeries	---	5798-RZG	---		S
System Openness Includes	---	5722-SS1 Option 13	---		S

OS/400 complementary database software	Skip ship ²	Product identifier	HIPO feature (5372-IS5) ²	Keyed stamped media ⁹	Software subscription or maintenance ⁸
NetWare Enhanced Integration	---	5722-SS1 Option 25	---		S
Portable Application Solution Environment	---	5722-SS1 Option 33	---		S
TCP/IP Connectivity Utilities for iSeries	---	5722-TC1	---		S
Client Access Express - Windows/iSeries Access for Windows	---	5722-XE1	---		S
iSeries Access for Web	New	5722-XH2			
iSeries Access for Wireless	New	5722-XP1			S
iSeries Access Family ^{6,7}	---	5722-XW1	1012 Client Processor - 1013 Client User	5050	S

Networking products	Skip ship ²	Product identifier	HIPO feature ² (5372-IS5)	Keyed stamped media ⁹	Software subscription or maintenance ⁸
Cryptographic Access Provider 128-bit ⁶	---	5722-AC3	1017		S
MQSeries for iSeries Version 5.2 ⁶	P	5733-A38	---	-	M
Host On-Demand Version 6.0	P	5733-A59	---		M
iSeries Client Encryption (128-bit) ⁶	---	5722-CE3	1019		S
Communications Utilities for iSeries ⁶	---	5722-CM1	1003	5050	S
Cryptographic Support for AS/400 ⁶	---	5722-CR1	1020		S
DCE Base Services for AS/400 ⁶	P	5769-DC1	1023		S
DCE DES Library Routines for AS/400 ⁶	P	5769-DC3	1024		S
Communications Server for Windows NT Version 6.1	P	5639-F25	---		---
Personal Communications for Windows Version 5.5	P	5639-I70 5733-A59*			M
iSeries Access for Windows	---	5722-XE1	---		S
iSeries Access for Web	New	5722-XH2 5722-XP1	---		S S
* ordering ID					

WebSphere and on demand business products	Skip ship ²	Product identifier	HIPO features ²	Keyed stamped media ⁹	Software subscription or maintenance ⁸
WebSphere V4.0.1 for iSeries ⁶	P	5722-AS4	---		S
Connect for iSeries V2 ¹⁰		5733-CO2	---		S
WebSphere Application Server - Express for iSeries		5722-IWE	6007		
WebSphere Advanced Edition V4.0.1 ⁶	P	5733-WA4	6000		M
WebSphere Advanced Edition Single Server V4.0.1	P	5733-WS4	6005		M
WebSphere Application Server		5733-WS5	6006		M

Systems management products	Skip ship ²	Product identifier	HIPO feature ²	Keyed stamped media ⁹	Software subscription or maintenance ⁶
Intelligent Communications Trace Analyzer for iSeries, Version 1.0	New	5733-AZ1			
Backup Recovery and Media Services for iSeries ⁶ Network Feature Advanced Feature	---	5722-BR1	1002 1507	5050 5101 5102	S
PATROL for iSeries – Predict	New	5620-FIF	---		S
Tivoli Storage Manager Enterprise Edition V5.1	---	5698-ISE	---		---
Tivoli Storage Manager V5.1	---	5698-ISM	---		---
Advanced Job Scheduler for iSeries ⁶	---	5722-JS1	1007	5050	S
Tivoli Management Agent	---	1TME-LCF	---		---
Managed System Services for iSeries ⁶	---	5722-MG1	1030		S
Performance Tools for iSeries ^{6,7} Manager Feature Agent Feature	---	5722-PT1 Option 1 Option2	1008 1508 1509	5050 5101 5102	S
Content Manager OnDemand for iSeries ⁶ PDF Indexer Feature Web Enablement Kit Feature	---	5722-RD1 Option 12 Option 11	1010 1510 1511		M
System Manager for iSeries ⁶	---	5722-SM1	1032		S
Software Subscription for iSeries 1-year	New	5733-SU1			
Software Subscription for iSeries 3-year	New	5733-SU3			
Software Technical Support for iSeries 1-year, renewable	New	5733-SX1			---
Software Technical Support for iSeries 3-year, renewable	New	5733-SX3			---

Application development products	Skip ship ²	Product identifier	HIPO feature ²	Keyed stamped media ⁹	Software subscription or maintenance ⁸
WebSphere Commerce Product V5.5		5724-A18	---		M
Screen Customizer Version 2.0.60	P	5648-D76	---		M
CICS Transaction Server for iSeries ⁶	---	5722-DFH	1025		S
ILC C Compiler		5799-GPC	6004		
Lotus Domino for iSeries Version 6.0	P	5733-LD6	---		M
Lotus Domino for iSeries Version 5.0	P	5769-LNT	---		M
QuickPlace for iSeries Version 2.0	P	5733-LQP	---		
Application Program Driver	P	5722-PD1	1031		S
Visualage Generator Server for iSeries	P	5769-VG1	1033		S
WebSphere Development Studio (Toolset)	---	5722-WDS	1015	5050	S
Application Development ToolSet ⁶	---	Option 21			
Application Development Manager	---	Option 22	1543		
Application Dictionary Services	---	Option 23	1544		

Application development products	Skip ship ²	Product identifier	HIPO feature ²	Keyed stamped media ⁹	Software subscription or maintenance ⁸
ILE RPG for iSeries ⁶	---	Options 31-35			
ILE COBOL for iSeries ⁶	---	Options 41-45			
ILE C++ for AS/400	---	Options 52, 54			
ILE C for AS/400 ⁶	---	Options 51, 53			
XML Toolkit for iSeries	P	5733-XT1	---		S

Office support and printing products	Skip ship ²	Product identifier	HIPO feature ²	Keyed stamped media ⁹	Software subscription or maintenance ⁸
Advanced Function Printing Utilities for AS/400 ⁶	---	5722-AF1	1001	5050	S
AFP PrintSuite for AS/400 ⁶ APU Advanced Print Utility PPFA Page Printer Formatting Aid AF3 SAP R3 AFP Print	P	5798-AF3 Option 1	- 1514	5101	S
Advanced DBCS Printer Support for AS/400 ⁶	---	5722-AP1	1014	5050	S
AFP Font Collection for Workstation and OS/400		5648-B45	---		
Dictionaries and Linguistic Tools for iSeries ⁶	P	5769-DL1	1026		M
Business Graphics Utility for AS/400 ⁶	---	5722-DS1	1027		S
Facsimile Support for iSeries	---	5798-FAX	---		S
Advanced Function Printing Fonts for AS/400 ⁶ Font Options	P	5769-FNT Options 1-15	--- ---		S
Advanced Function Printing DBCS Fonts for AS/400 ^{6†} Font Options	P	5769-FN1	--- 1535-1539		S
Domino Fax for iSeries		5733-FXD	---		S
Infoprint Designer for iSeries	P	5733-ID1	6003		S
Infoprint Server for iSeries	---	5722-IP1	1006	5050	S
Content Manager for iSeries Object Server Advanced Workflow	P	5722-VI1 Option 1 Option 4	1034 --- ---		M

Additional and packaged products	Skip ship ²	Product identifier	HIPO feature ²	Keyed stamped media ⁹	Software subscription or maintenance ⁸
Host Access Client Package for iSeries, Version 3.0 Personal Communications V5.6 Screen Customizer Version 1.0.70 WebSphere Host On-Demand V7.0		5733-A78	---		
Host Access Client Package for multiplatforms, Version 3.0 Personal Communications V5.6 Screen Customizer V2.0.70 WebSphere Host On-Demand V7.0		5648-E81	---		
Lotus Enterprise Integrator for iSeries ⁶	---	5769-LNP	---		M
Lotus Domino Enterprise Server for iSeries	P	5769-LNT	6001		M
CISC to RISC Upgrade Kit		5798-TBU	---		
ValuPak for V5R2: 5722-SS1: OS/400 5722-SS1: 1-45 ipm feature 5722-XW1: Client Access Family/iSeries Access 5722-QU1: Query 400 5722-ST1: DB2/400 Query Manager and SQL Development Kit 5722-PT1: Performance Tools (Manager feature)		5722-VP1	---		

10.9 OS/400 V5R1 software

The following tables show the V5R1 OS/400-based software products that are most commonly installed. It is not a definitive list of all possible IBM software products for the iSeries or AS/400e. See 10.10, "Notes for Version 5 software tables" on page 366, for Version 5 software group information.

Operating system and base products	Skip ship ²	Product identifier	HIPO feature (5372-IS5) ² V5R1	Keyed stamped media ⁹	Software subscription or maintenance ⁸
Operating System/400 ^{6,7}	---	5722-SS1	1000	5050	S
Media and Storage Extensions	---	5722-SS1 Option 18	1500	5103	S
OptiConnect for OS/400	---	5722-SS1 Option 23	1515		S
DB2 Symmetric Multiprocessing	---	5722-SS1 Option 26	1517		S
DB2 MultiSystem	---	5722-SS1 Option 27	1518		S
Print Services Facility (PSF/400) 1-45 IPM 1-100 IPM Any speed	---	5722-SS1 Option 36 Option 37 Option 38	--- --- 1503	5112 5113 5114	S
S/38 Utilities for AS/400 ⁶	---	5722-DB1	1521		S
HTTP Server for iSeries	---	5722-DG1	---		S
IBM Toolbox for Java	---	5722-JC1	---		S

Operating system and base products	Skip ship ²	Product identifier	HIPO feature (5372-IS5) ² V5R1	Keyed stamped media ⁹	Software subscription or maintenance ⁸
IBM Developer Kit for Java	---	5722-JV1	---		S
DB2 Query Manager and SQL Development Kit for iSeries ^{6, 7}	---	5722-ST1	1011	5050	S
iSeries Integration for Windows Server	---	5722-WSV	---		S

OS/400 complementary database software	Skip ship ²	Product identifier	HIPO feature (5372-IS5) ²	Keyed stamped media ⁹	Software subscription or maintenance ⁸
DCE Base Services		5769-DC1	1023		S
DCE DES Library Routines		5769-DC3	1024		S
DB2 Universal Database Extenders for iSeries V7.2	---	5722-DE1	---	5050	S
DB2 DataPropagator for iSeries Version 7.1 ⁶ (V5R1)	P	5769-DP3	1005	5050	S
QMF for Windows for iSeries	V5R1	5697-G24	---		S
DB2 Table Editor for iSeries	V5R1	5697-G84	---		S
DB2 Web Query Tool	V5R1	5697-G85	---		S
DB2 Intelligent Miner for Data V6.1	V5R1	5733-IM3	---		S
iSeries ODBC Driver for Linux	---	5733-LO1	---		
DB2 OLAP Server for iSeries V7.1	---	5686-OLP	---		
Query for iSeries ^{6, 7}	---	5722-QU1	1009	5050	S
Electronic Service Agent for iSeries		5798-RZG	---		
System Openness Includes	---	5722-SS1 Option 13	---		S
NetWare Enhanced Integration	---	5722-SS1 Option 25	---		S
Portable Application Solution Environment	---	5722-SS1 Option 33	1519		S
TCP/IP Connectivity Utilities for iSeries	---	5722-TC1	---		S
Client Access Express - Windows/iSeries Access for Windows	---	5722-XE1	---		S
iSeries Access Family ^{6,7}	---	5722-XW1	1012	5050	S

Networking products	Skip ship ²	Product identifier	HIPO feature ² (5372-IS5)	Keyed stamped media ⁹	Software subscription or maintenance ⁸
Cryptographic Access Provider 56-bit ⁶ (V5R1)	---	5722-AC2	1016		S
Cryptographic Access Provider 128-bit ⁶	---	5722-AC3	1017		S
MQSeries for iSeries (V5.2) ⁶	P	5733-A38	---	-	S
iSeries Client Encryption (56-bit) ⁶ (V5R1)	---	5722-CE2	1018		S
iSeries Client Encryption (128-bit) ⁶	---	5722-CE3	1019		S
Communications Utilities for iSeries ⁶	---	5722-CM1	1003	5050	S
Cryptographic Support for AS/400 ⁶	---	5722-CR1	1520		S
DCE Base Services for AS/400 ⁶	P	5769-DC1	1023		S
DCE DES Library Routines for AS/400 ⁶	P	5769-DC3	1024		S
Communications Server for Windows NT	V5R1	5639-F25	---		
MQSeries Integrator for iSeries (V5R1)	---	5697-F49	---		S
iSeries Access for Windows	---	5722-XE1	---		S

WebSphere and on demand business products	Skip ship ²	Product identifier	HIPO features ²	Keyed stamped media ⁹	Software subscription or maintenance ⁸
WebSphere Standard Edition ⁶ (V5R1)	P	5733-AS3	---		S
Connect for iSeries (V5R1)	P	5733-B2B	---		S
WebSphere Advanced Edition V3.5 ⁶	P	5733-WA3	6002		S
WebSphere Advanced Edition V4.0.1 ⁶	---	5733-WA4	6000		S
WebSphere Advanced Edition Single Server V4.0.1	---	5733-WS4	---		S

Systems management products	Skip ship ²	Product identifier	HIPO feature ²	Keyed stamped media ⁹	Software subscription or maintenance ⁸
Backup Recovery and Media Services for iSeries ⁶	---	5722-BR1	1002	5050	S
Network Feature	---		1506	5101	
Advanced Feature	---		1507	5102	
Advanced Job Scheduler for iSeries ⁶	---	5722-JS1	1007	5050	S
Tivoli Management Agent		1TME-LCF	---		---
Managed System Services for iSeries ⁶	---	5722-MG1	1030		S
Performance Tools for iSeries ^{6,7}	---	5722-PT1	1008	5050	S
Manager Feature		Option 1	1508	5101	
Agent Feature		Option2	1509	5102	
Content Manager OnDemand for iSeries ⁶	---	5722-RD1	1010		S
PDF Indexer Feature		Option 12	1510		
Web Enablement Kit Feature		Option 11	1511		
System Manager for iSeries ⁶	---	5722-SM1	1032		S

Application development products	Skip ship ²	Product identifier	HIPO feature ²	Keyed stamped media ⁹	Software subscription or maintenance ⁸
CICS Transaction Server for iSeries ⁶	---	5722-DFH	1025		S
Lotus Domino for iSeries		5733-LD6	---		S
Lotus Domino for iSeries		5769-LNT	---		S
QuickPlace for iSeries		5733-LQP	---		
Application Program Driver	P	5722-PD1	1031		S
WebSphere Payment Manager for iSeries (V5R1)	P	5733-PY2	---		S
Visualage Generator Server for iSeries	P	5769-VG1	1033		S
WebSphere Commerce Suite, Pro Edition for AS/400, Version 4.1	P	5798-WC4	-		S
WebSphere Commerce Suite, Pro Edition for iSeries, Version 5.1	P	5798-WC5	---		S
WebSphere Development Studio (Toolset)	---	5722-WDS	1015	5050	S
ILE COBOL for iSeries ⁶	---	Options 41-45			
ILE RPG for iSeries ⁶	---	Options 31-35			
ILE C++ for AS/400	---	Options 52, 54			
ILE C for AS/400 ⁶	---	Options 51, 53			
Application Development ToolSet ⁶	---	Option 21			
Application Development Manager	---	Option 22	1543		
Application Dictionary Services	---	Option 23	1544		
XML Toolkit for iSeries		5733-XT1	---		S

Office support and printing products	Skip ship ²	Product identifier	HIPO feature ²	Keyed stamped media ⁹	Software subscription or maintenance ⁸
Advanced Function Printing Utilities for AS/400 ⁶	---	5722-AF1	1001	5050	S
AFP PrintSuite for AS/400 ⁶ APU Advanced Print Utility PPFA Page Printer Formatting Aid AF3 SAP R3 AFP Print	P	5798-AF3 Option 1	- ---	5101	M
Advanced DBCS Printer Support for AS/400 ⁶	---	5722-AP1	1014	5050	S
AFP Font Collection for Workstation and OS/400		5648-B45	---		
Dictionaries and Linguistic Tools for iSeries ⁶	P	5769-DL1	1026		S
Business Graphics Utility for AS/400 ⁶	---	5722-DS1	1027		S
Facsimile Support for iSeries	---	5798-FAX	-		S
Advanced Function Printing Fonts for AS/400 ⁶	P	5769-FNT	-		S

Office support and printing products	Skip ship ²	Product identifier	HIPO feature ²	Keyed stamped media ⁹	Software subscription or maintenance ⁸
Font Options		Options 1-15	1520-1534		
Advanced Function Printing DBCS Fonts for AS/400 ^{6†} Font Options	P	5769-FN1	- 1535-1539		S
Domino Fax for iSeries		5733-FXD	---		S
Infoprint Designer for iSeries	---	5733-ID1	6003		S
Infoprint Server for iSeries	---	5722-IP1	1006	5050	S
Content Manager for iSeries	P	5722-VI1	1034		S
Object Server		Option 1	--		
Advanced Workflow		Option 4	--		

Additional and packaged products	Skip ship ²	Product identifier	HIPO feature ²	Keyed stamped media ⁹	Software subscription or maintenance ⁸
Lotus Enterprise Integrator for iSeries ⁶	P	5769-LNP	---		S
Lotus Domino Enterprise Server for iSeries	P	5769-LNT	6001		S
CISC to RISC Upgrade Kit		5798-TBU	---		
ValuPak for V5R1: 5722-SS1: OS/400 5722-SS1: 1-45 ipm feature 5722-XW1: Client Access Family/iSeries Access 5722-QU1: Query 400 5722-ST1: DB2/400 Query Manager and SQL Development Kit 5722-PT1: Performance Tools (Manager feature)		5722-VP1	---		

10.10 Notes for Version 5 software tables

Note 1	<p>V5 is supported on the following AS/400e RISC models <i>only</i>. See the overview table in the model chapters for the <i>minimum</i> OS/400 release to support each model.</p> <ul style="list-style-type: none"> ▶ 9401-150 (V5R1 does not support 5649-<i>nnn</i> products. 5722-<i>nnn</i> programs in group P05 support the 9401-150.) ▶ 9402/4-4xx (V5R1 only) ▶ 9404/6-5xx (V5R1 only) ▶ 9402/4/6-620, 630, 640, S20, S30, S40 ▶ 9406-170 ▶ 9402/4/6-720, 730, 740 ▶ 9406-250 ▶ 9402/4/6-270 ▶ 9402/4/6-800, 810, 820, 825, 830, 840, 870, 890 ▶ 9406-SB2/SB3 ▶ 9405-520 ▶ 9406-520, 550, 570, 595 <p>V5 <i>is not</i> supported on any AS/400 CISC models.</p>
---------------	---

<p>Note 2</p>	<p>Products marked with a “✓” in the Skip ship column are unchanged from a previous version or release and are referred to as being “skip shipped”. These products retain their original product identifiers.</p> <p>The HIPO feature column provides the feature codes that are included in the HIPO (5732-IS5) when a specific product or feature is ordered to be preloaded in the factory. If you order a software upgrade, or if the initial order does not include the #5000 software preload code, the order does not include the HIPO (5732-IS5).</p> <p>With the introduction of Keyed Stamped Media in V4R4, all products the client ordered are no longer “stacked” on a single set of CDs. The client receives a grouping of CDs. With V5R2, this includes:</p> <ul style="list-style-type: none"> ▶ Licensed Internal Code (I_Base_01) ▶ OS/400 Base Operating System CD (B29xx_01) ▶ OS/400 No Charge Options (B29xx_02 to B29xx_06) ▶ No charge License Programs (B29xx_07 to B29xx_09) ▶ Set of Keyed Stamped Media CDs (L29xx_01 to L29xx_02) ▶ Individual CD for each product ordered that is not part of Keyed Stamped Media (F29xx_01 and higher) ▶ Cumulative PTF CDs (Cyddvrm_01) ▶ Secondary Languages if ordered (N29xx_01) ▶ iSeries Information Center (SK3T-4091) 																																																						
<p>Note 4</p>	<p>Alternate IPL Device Feature Codes:</p> <p>The following feature codes are hardware features. They are used to specify which storage device is to be used as an alternate IPL device. They are not required when ordering Models 800, 810, 825, 870, and 890.</p> <ul style="list-style-type: none"> ▶ #5502 840 MB Mini ¼-inch Cartridge Tape Unit (not 250, 270, 520, 550, 570, 595, 720, 730, 740, 800, 810, 820, 825, 830, 840, 870, 890) ▶ #5503 9347 Tape Unit (not 250, 270, 520, 550, 570, 595, 800, 810, 820, 825, 830, 840, 870, 890) ▶ #5504 3490 E01/E11 Tape Units * ▶ #5505 2440 Tape Unit (not 250, 270, 520, 550, 570, 595, 800, 810, 820, 825, 830, 840, 870, 890) ▶ #5506 4 GB ¼-inch Cartridge Tape Unit * ▶ #5507 9348 Tape Unit * ▶ #5508 3422 Tape Subsystem (not 250, 270, 520, 550, 570, 595, 800, 810, 820, 825, 830, 840, 870, 890) ▶ #5509 3430 Tape Subsystem (not 250, 270, 520, 550, 570, 595, 800, 810, 820, 825, 830, 840, 870, 890) ▶ #5511 3480 Tape Subsystem * ▶ #5512 3490 C10/C11/C22 Tape Unit * ▶ #5513 3490 Tape Subsystem * ▶ #5514 7208 8 mm Tape Drive and Internal 8 mm Tape Unit * ▶ #5515 3570 Tape Subsystem * ▶ #5516 1.2 GB ¼-inch Cartridge Tape Unit ▶ #5517 2.5 GB ¼-inch Cartridge Tape Unit * ▶ #5518 13 GB ¼-inch Cartridge Tape Unit ▶ #5519 3590 Tape System * ▶ #5521 * ▶ #5531 16 GB or 30 GB ¼-inch Cartridge Tape Unit * ▶ #5536 25 GB or 50 GB ¼-inch Cartridge Tape Unit * ▶ #5537 358x Ultrium * ▶ #5538 DVD-RAM * ▶ #5599 No Save/Restore Device * <p>Refer to Chapter 7, “Storage and media for IBM System i5, eServer i5, and iSeries models” on page 291, and the internal tape unit sections of each processor’s chapter to see which tapes are supported for that model.</p> <p>Features #5504, #5506, #5507, #5511, #5512, #5513, #5514, #5515, #5517, #5519, #5521, #5531, #5536, #5537, #5538, and #5599 were withdrawn from marketing as of 1 December 2005.</p>																																																						
<p>Note 5</p>	<p>Maximum number of chargeable users by product</p> <table border="1" style="width: 100%; border-collapse: collapse;"> <thead> <tr> <th colspan="2"></th> <th colspan="7" style="text-align: center;">Maximum number of users</th> </tr> <tr> <th colspan="2"></th> <th>P05</th> <th>P10</th> <th>P20</th> <th>P30</th> <th>P40</th> <th>P50</th> <th>P60</th> </tr> </thead> <tbody> <tr> <td>5722-DFH</td> <td>CICS for iSeries</td> <td>450</td> <td>450</td> <td>450</td> <td>450</td> <td>450</td> <td>450</td> <td>450</td> </tr> <tr> <td>5722-RD1</td> <td>OnDemand for iSeries - concurrent user</td> <td>--</td> <td>--</td> <td colspan="2">No maximum limit</td> <td>--</td> <td>--</td> <td>--</td> </tr> <tr> <td>5769-V11</td> <td>Content Manager for iSeries</td> <td>--</td> <td>--</td> <td colspan="2">No maximum limit</td> <td>--</td> <td>--</td> <td>--</td> </tr> </tbody> </table> <p>The number of individual user licenses that, when priced, equates the tier (based on processor) pricing and is the maximum that can be used in a conversion for user based to tier (processor) pricing in that tier:</p> <table border="1" style="width: 100%; border-collapse: collapse;"> <tbody> <tr> <td>5722-XW1</td> <td>iSeries Access Family</td> <td>10</td> <td>40</td> <td>100</td> <td>150</td> <td>200</td> <td>250</td> <td>300</td> </tr> </tbody> </table>			Maximum number of users									P05	P10	P20	P30	P40	P50	P60	5722-DFH	CICS for iSeries	450	450	450	450	450	450	450	5722-RD1	OnDemand for iSeries - concurrent user	--	--	No maximum limit		--	--	--	5769-V11	Content Manager for iSeries	--	--	No maximum limit		--	--	--	5722-XW1	iSeries Access Family	10	40	100	150	200	250	300
		Maximum number of users																																																					
		P05	P10	P20	P30	P40	P50	P60																																															
5722-DFH	CICS for iSeries	450	450	450	450	450	450	450																																															
5722-RD1	OnDemand for iSeries - concurrent user	--	--	No maximum limit		--	--	--																																															
5769-V11	Content Manager for iSeries	--	--	No maximum limit		--	--	--																																															
5722-XW1	iSeries Access Family	10	40	100	150	200	250	300																																															

Note 6	<p>These products are licensed using the International Program License Agreement (IPLA). The remaining V4 licensed programs are licensed under the International Customer Agreement (ICA) or IBM Agreement for Programs (IAP) terms.</p> <p>Three documents, <i>Proof of Entitlement (POE)</i>, <i>License Information Document (LID)</i>, and <i>International Program License Agreement</i>, are provided with IPLA software as proof of a valid license. IPLA software can be sold to another party. You must notify the purchaser of the program's terms and provide the POE, LID, and IPLA documents to the purchaser. IBM licenses the purchaser when that party accepts the program's license terms by initial use of the program. The seller's license is terminated at this time.</p> <p>When ordering upgrades to software licensed under the IPLA, such as OS/400, a copy of the POE should be provided by the client to validate the license to the software.</p>																		
Note 7	<p>The following products are also offered in software packages:</p> <p>5722-VP1 ValuPak for OS/400 (not available on OS/400 V4R5) includes:</p> <table border="0"> <tr> <td>5722-SS1</td> <td>Operating System/400</td> <td></td> </tr> <tr> <td>5722-PSF</td> <td>1-45 ipm Option 36 of OS/400</td> <td>Provides this number of users</td> </tr> <tr> <td>5722-XW1</td> <td>iSeries Access Family for Windows XW1:</td> <td>P05/10 P10/20 P20/50 P30/70 P40/125 P50/150</td> </tr> <tr> <td>5722-QU1</td> <td>Query/400</td> <td>P60/175</td> </tr> <tr> <td>5722-ST1</td> <td>DB2/400 Query Manager and SQL Development Kit</td> <td></td> </tr> <tr> <td>57xx-PT1</td> <td>Performance Tools (Option 1 Manager feature)</td> <td></td> </tr> </table>	5722-SS1	Operating System/400		5722-PSF	1-45 ipm Option 36 of OS/400	Provides this number of users	5722-XW1	iSeries Access Family for Windows XW1:	P05/10 P10/20 P20/50 P30/70 P40/125 P50/150	5722-QU1	Query/400	P60/175	5722-ST1	DB2/400 Query Manager and SQL Development Kit		57xx-PT1	Performance Tools (Option 1 Manager feature)	
5722-SS1	Operating System/400																		
5722-PSF	1-45 ipm Option 36 of OS/400	Provides this number of users																	
5722-XW1	iSeries Access Family for Windows XW1:	P05/10 P10/20 P20/50 P30/70 P40/125 P50/150																	
5722-QU1	Query/400	P60/175																	
5722-ST1	DB2/400 Query Manager and SQL Development Kit																		
57xx-PT1	Performance Tools (Option 1 Manager feature)																		
Note 8	<p>SWMA = iSeries Software Maintenance PA = Passport Advantage® Software Maintenance Product Code = Separate Maintenance by individual product codes New versions and updates to these products are covered by one of these three methods.</p> <p>“SWMA” indicates that the product is on the Eligible Products List for Software Subscription. Clients must purchase Software Maintenance Subscription when they move to Version 4 or higher to upgrade to new versions or releases. Software Subscription is available at prepaid options of one or three years.</p> <p>Software Maintenance for some products is covered by Passport Advantage. Products must be registered via the Passport Advantage Web site. For further information view: http://www-142.ibm.com/software/sw-lotus/services/cwpassport.nsf/wdocs/softwaremaintenance</p> <p>The third method is by purchasing an individual product code that covers an individual product. For example, clients purchasing VE Enterprise Workload Manager for i5/OS V2.1 (5733-EWA) would need to purchase 5662-EWA to have a 3-Year Registration for the product.</p> <p>The price of Software Subscription is the same regardless of whether the software has been licensed to a system. Most iSeries software delivered by HIPO is covered by Software Subscription. Clients who do not have a valid Software Maintenance are not entitled to new Versions or Releases and must either re-license the software or purchase the After License For iSeries license to join if they want to upgrade to a new version or release. You can find a current list of program products covered by Software Subscription on the Web at: http://www-1.ibm.com/servers/eserver/series/sftsol/subscript2.htm</p> <p>Software Subscription is ordered as a unique product/model combination depending upon the method of payment:</p> <ul style="list-style-type: none"> ▶ 5733-SW1 Software Subscription for AS/400 1-Year Prepay. <i>Withdrawn from marketing.</i> ▶ 5733-SW3 Software Subscription for AS/400 3-Year Prepay. <i>Withdrawn from marketing.</i> ▶ 5733-CA1 After License for iSeries <p>For the prepayment options and the Subscription After License, specify the corresponding processor-based feature for 5733-SWx.</p> <p>“M” indicates Software Maintenance, which differs from Software Subscription. It requires maintenance to be purchased separately based on individual product. Some products that were covered by Software Subscription are now covered by Software Maintenance. Clients that have these products covered under an existing Software Subscription are still eligible for upgrades under Software Subscription, but need to carefully plan their requirements when that Software Subscription expires. You can find a list of program products covered by Software Maintenance and their Maintenance product codes on the Web at the same site listed earlier in this note.</p>																		

Note 9	<p>A number (representing the Installation ID of the product) in the Keyed Stamped Media column indicates that the product is one of those provided in V5R1 on iSeries Keyed Stamped Media and shipped with OS/400. This is to provide on demand delivery of these products and features and allows a 70-day evaluation period for any of the provided products or features. To use the software distributed on the keyed stamped media after the 70-day evaluation period, order a Software License Key. New Software License Keys are also required when the version, release, or modification level of the software changes. If the software is transferred to a different system, a new software key is required. Some software is keyed based on the Software group, and a new software key must be obtained when the Software group changes.</p> <p>When a Software License Key is ordered, retain the <i>Software License Key Sheet</i> that IBM provides.</p> <p>If a Keyed Stamped Media product or feature is to be upgraded, the current Software License Key Sheet for the product must be provided as proof of license.</p>
Note 10	<p>DB2 OLAP Server for iSeries V8.1 (5724-B78) is withdrawn from IBM marketing as of 09 November 2005. Connect for iSeries V2 (5733-CO2) is withdrawn from IBM marketing as of 13 December 2005. WebSphere Application Server Version 5.1 Developer Edition for iSeries (5724-D18) is withdrawn from IBM marketing as of 14 September 2005. The replacement product is WebSphere Application Server Version 6.0 Developer Edition for iSeries (5724-H89).</p>

10.11 i5/OS and OS/400 software pricing groups

OS/400 software is priced by software groups. This section shows the software group for each iSeries and AS/400e processor for Version 5 and Version 4. Use the Work with License Information (WRKLICINF) command to display the software group of the installed AS/400e or iSeries server.

For information about software groups for earlier systems, refer to *IBM eServer AS/400e RISC System Builder Version 3 Release 6 - Version 5 Release 2*, REDP-0342.

10.11.1 i5/OS and OS/400 Version 5 software groups

The following table shows the software group for each IBM System i5, IBM eServer i5, iSeries, and AS/400e processor supported by i5/OS Version 5 Release 4 or Release 3, or OS/400 Version 5 Release 2 or Release 1.

Hardware models	Processor feature	Interactive feature or Server/Edition feature	Version 5 group
520	#8325	#0970 / #7140, #7141, #7142	P05
	#8325	#0975 / #7350	P05
	#8327	#0906 / #7366, #7373, #7374, #7734, #7735, #7784	P10
	#8327	#0970 / #7143, #7144, #7148, #7152	P10
	#8327	#0975 / #7352	P10
	#8330	#0906 / #7375, #7736, #7785	P20
	#8950	#0900 / #7450, #7390, #7391, #7393	P05
	#8951	#0901 / #7392, #7394, #7451	P10
	#8952	#0902 / #7458, #7459, #7541, #7552	P10
	#8953	#0903 / #7452, #7453, #7553	P10
	#8954	#0904 / #7454, #7455, #7553	P20
	#8955	#0905 / #7456, #7457, #7455	P20
	#8972	#8972 / #7395, #7396	P10
550	#8958	#0915 / #7462, #7463, #7530, #7531, #7532, #7533, #7534, #7558	P20
	#8312	#0910 / #7154, #7155, #7551, #7629, #7630, #7631, #7632, #7640, #7641	P20

Hardware models	Processor feature	Interactive feature or Server/Edition feature	Version 5 group
570	#8961	#0919 / #7488, #7489	P30
	#8961	#0920 / #7469, #7470	P30
	#8971	#0921 / #7494, #7495, #7560	P30
	#8971	#0922 / #7471, #7472, #7561	P40
	#8971	#0924 / #7473, #7474, #7562	P40
	#8971	#0926 / #7475, #7476, #7563	P40
	#8971	#0928 / #7570	P30
	#8971	#0930 / #7490, #7491, #7559	P30
	#8338	#0934 / #7747, #7757, #7763	P30
	#8338	#0935 / #7748, #7758, #7764	P40
	#8338	#0936 / #7749, #7759, #7765	P40
595	#8981	#0946 / #7496, #7497	P50
	#8981	#0947 / #7498, #7499	P50
	#8981	#0952 / #7984, #7985	P60
	#8966	#0940 / #7480, #7481, #7580	P50
	#8966	#0941 / #7482, #7483, #7581	P50
	#8966	#0943 / #7486, #7487, #7583	P60
	#8966	#0944 / #7590	P50
720	#2061	#1500	P10
		#1501, #1502	P20
	#2062	#1500	P10
		#1501, #1502, #1503	P20
	#2063	#1500	P20
		#1502, #1503, #1504	P30
#2064	#1500	P20	
		#1502, #1503, #1504, #1505	P30
730	#2065	#1506	P20
		#1507, #1508, #1509	P30
	#2066	#1506	P20
		#1507, #1508, #1509, #1510	P30
	#2067	#1506	P30
		#1508, #1509, #1510, #1511	P40
	#2068	#1506	P30
		#1508, #1509, #1510, #1511	P40
740	#2069	#1510, #1511, #1512	P50
		#1514	P40
	#2070	#1510, #1511, #1512, #1513	P50
		#1514	P40
800	#2463	#7400	P05
	#2464	#7408	P10
810	#2465	#7404, #7406	P10
	#2466	#7407, #7408, #7409	P10
	#2467	#7410, #7411, #7412	P10
	#2469	#7428, #7429, #7430	P20

Hardware models	Processor feature	Interactive feature or Server/Edition feature	Version 5 group
820	#0150, #0151	-	P20
	#0152	-	P30
	#2395	#1521	P10
		#1522, #1523, #1524	P20
	#2396	#1522, #1523, #1524, #1525	P30
	#2397	#1521	P20
		#1522, #1523, #1524, #1525, #1526	P30
	#2398	#1521	P30
		#1522, #1523, #1524, #1525, #1526, #1527	P40
	#2425	-	P05
	#2426, #2427	-	P10
	#2435	#1521	P10
		#1522, #1523, #1524	P20
	#2436	#1521	P20
		#1522, #1523, #1524	P30
	#2437	#1521	P20
		#1522, #1523, #1524, #1526, #1527	P30
	#2438	#1521	P30
#1522, #1523, #1524, #1525, #1526, #1527		P40	
#2456	-	P05	
#2457, #2458	-	P10	
825	#2473, #2495	#7416, #7418, #7434, #7439	P30
830	#0153	-	P30
	#2349	#1531	P30
		#1532, #1533, #1534, #1535, #1536, #1537	P40
	#2400	#1531	P20
		#1532, #1533, #1534, #1535	P30
	#2402	#1531	P30
		#1532, #1533, #1534, #1535, #1536	P40
#2403	#1531	P40	
	#1532, #1533, #1534, #1535, #1536, #1537	P50	

Hardware models	Processor feature	Interactive feature or Server/Edition feature	Version 5 group
840	#0158, #0159	-	P40
	#2352	#1540	P40
		#1541, #1542, #1543, #1544, #1545, #1546	P50
	#2353	#1540	P40
		#1541, #1542, #1543, #1544, #1545, #1546, #1547	P50
	#2354	#1540	P40
		#1541, #1542, #1543, #1544, #1545, #1546, #1547, #1548	P50
	#2416	#1540	P40
		#1541, #1542, #1543, #1544, #1545, #1546	P40
	#2417	#1540	P40
		#1541, #1542, #1543, #1544, #1545, #1546	P50
	#2418	#1540	P40
		#1541, #1542, #1543, #1544, #1545, #1546	P50
	#2419	#1540	P40
		#1541, #1542, #1543, #1544, #1545, #1546, #1547	P50
	#2420	#1540	P40
#2420	#1541, #1542, #1543, #1544, #1545, #1546, #1547	P50	
#2461	#1540	P40	
	#1541, #1542, #1543, #1544, #1545, #1546, #1547, #1548	P50	
870	#2486	#7419, #7421, #7436	P40
	#2489	#7431, #7433, #7435	P40
	#2496	#7440	P40
890	#0197, #0198	-	P50
	#2487	#1576	P50
	#2487	#1577, #1578, #1579, #1581, #1583, #1585, #1587, #1588	P60
	#2488	#1576	P50
		#1577, #1578, #1579, #1581, #1583, #1585, #1587, #1588, #1591	P60
#2497, #2498, #2499	#7422, #7424 #7425, #7427, #7437, #7438, #7441	P50	
9411-100	9117-570	-	P30
	9119-595	-	P30

10.11.2 OS/400 Version 4 software groups

The following table shows the software group for each iSeries and AS/400e processor supported by OS/400 Version 4.

Hardware model	Processor feature	Interactive feature	Version 4 group
250	#2295, #2296	-	PPS

Hardware model	Processor feature	Interactive feature	Version 4 group
270	#2248	#1517	P05
	#2250	#1516, #1518	P10
	#2252	#1516, #1519	P10
	#2253	#1516, #1520	P20
	#2422, #2423	-	P05
	#2424	-	P10
	#2431	#1518	P10
	#2432	#1516, #1519	P10
	#2434	#1516, #1520	P20
	#2452, #2454	-	P05
720	#2061	#1500	P10
		#1501, #1502	P20
	#2062	#1500	P10
		#1501, #1502, #1503	P20
	#2063	#1500	P20
		#1502, #1503, #1504	P30
	#2064	#1500	P20
		#1502, #1503, #1504, #1505	P30
730	#2065	#1506	P20
		#1507, #1508, #1509	P30
	#2066	#1506	P20
		#1507, #1508, #1509, #1510	P30
	#2067	#1506	P30
		#1508, #1509, #1510, #1511	P40
	#2068	#1506	P30
		#1508, #1509, #1510, #1511	P40
740	#2069	#1510, #1511, #1512	P50
		#1514	P40
	#2070	#1510, #1511, #1512, #1513	P50
		#1514	P40
820	#2395	#1521	P10
		#1522, #1523, #1524	P20
	#2396	#1521	P20
		#1522, #1523, #1524, #1525	P30
	#2397	#1521	P20
		#1522, #1523, #1524, #1525, #1526	P30
	#2398	#1521	P30
		#1522, #1523, #1524, #1525, #1526, #1527	P30 or P40
#2425	---	P05	
#2426, #2427	---	P10	
830	#2400	#1531	P20
		#1532, #1533, #1534, #1535, #1536, #1537	P30
	#2402	#1531	P30
		#1532, #1533, #1534, #1535, #1536	P40
	#2403	#1531	P40
		#1532, #1533, #1534, #1535, #1536, #1537	P50

Hardware model	Processor feature	Interactive feature	Version 4 group	
840	#2416	#1540	P40	
		#1541, #1542, #1543, #1544, #1545, #1546, #1547	P50	
	#2417	#1540	P40	
		#1541, #1542, #1543, #1544, #1545, #1546, #1547	P50	
	#2418	#1540	P40	
		#1541, #1542, #1543, #1544, #1545, #1546, #1547	P50	
	#2419	#1540	P40	
		#1541, #1542, #1543, #1544, #1545, #1546, #1547	P50	
	#2420	#1540	P40	
		#1541, #1542, #1543, #1544, #1545, #1546, #1547	P50	
	SB2	#2315	-	P30
	SB3	#2316, #2318	-	P40

10.12 Release-to-release software product mapping

The following table shows a list of System i software products, with the product number associated with each i5/OS and OS/400 release level. Use this information to understand how a particular software product is offered for a given i5/OS or OS/400 installed release.

The products are listed in sequential order by the software product's model number in the right-most column (the latest release of i5/OS). For example, 5722-SS1 is listed prior to 5722-TC1 and after 5733-CO2. V5R2 is the column used as a sorting reference.

An asterisk (*) in the column indicates the product is skip-shipped for that release. The dashes (--) indicate that the product was not offered for that release. The letters N/A indicate that the product is not supported for that release.

Refer to *IBM eServer AS/400e RISC System Builder Version 3 Release 6 - Version 5 Release 2*, REDP-0342, for a software product map for releases prior to OS/400 V4R2.

For a list of withdrawn software products and their recommended replacements, and further information, refer to the iSeries Planning Web site at:

<http://www.ibm.com/servers/eserver/series/support/planning>

V4R2	V4R3	V4R4	V4R5	V5R1	V5R2	V5R3	V5R4
---	---	---	---	---	5724-A18	*	N/A
5769-MQ2	*	*	5733-A38	*	*	P/N	P/N
---	---	---	5733-A47	*	N/A	N/A	N/A
---	---	5648-DO1	5648-DO1	5733-A61	5733-A78	5724-F68	5724-I20
---	---	5748-C54	*	5733-A61	5733-A78	5724-F68	5724-I20
---	5769-AC2	*	*	5722-AC2	N/A	N/A	N/A
---	5769-AC1	*	*	5722-AC3	5722-AC3	5722-AC3	N/A
5769-AF1	*	*	*	5722-AF1	5722-AF1	*	*
5798-AF3	*	*	*	*	*	N/A	N/A
5769-AP1	*	*	*	5722-AP1	5722-AP1	5722-AP1	*
---	---	5769-AS1	*	5733-AS3	5724-D06	5722-WE2	5722-WE2
---	---	---	---	---	5733-AZ1		
5769-BR1	*	*	*	5722-BR1	5722-BR1	5722-BR1	5722-BR1
---	---	---	---	---	5724-B08	5724-E66	N/A
---	---	---	---	---	5648-B45	*	*
---	---	---	5733-B2B	*	5733-CO2	*	N/A
5716-CP2*	5769-CP4	*	5648-C69	*	N/A	N/A	N/A
---	---	5769-CE1	*	N/A	N/A	N/A	N/A
---	---	5769-CE2	*	5722-CE2	N/A	N/A	N/A
---	---	5769-CE3	*	5722-CE3	5722-CE3	5722-CE3	N/A
5769-CF1	*	5769-CF1	*	N/A	N/A	N/A	N/A
5769-CM1	*	5769-CM1	*	5722-CM1	5722-CM1	5722-CM1	5722-CM1
5769-CP4	*	*	N/A	N/A	N/A	N/A	N/A
5769-CR1	*	5769-CR1	*	5722-CR1	5722-CR1	*	*
---	---	---	---	---	---	5733-CY1	5733-CY1
5769-DB1	*	5769-DB1	*	5722-DB1	5769-DB1	5769-DB1	5722-DB1
---	5769-DC1	*	*	*	*	N/A	N/A
---	5769-DC3	*	*	*	*	N/A	N/A
---	---	---	---	---	---	5733-DIR	5733-DIR
---	---	---	---	---	---	5733-DR1	5733-DR1
---	---	---	---	5722-DE1	5722-DE1	5722-DE1	5722-DE1
5769-DFH	5769-DFH	5769-DFH	*	5722-DFH	5722-DFH	5722-DFH	5722-DFH
5716-DCT*	*	*	5769-DL1	*	*	N/A	N/A
5769-DP1	5769-DP2	*	5769-DP3	*	5722-DP4	*	*
5769-DS1	*	*	*	5722-DS1	5722-DS1	5722-DS1	5722-DS1
---	---	---	---	---	---	5648-E77	5648-E77
---	---	---	5648-E09	5733-A57	5733-E81	5724-F69	5724-I20
---	---	---	---	---	---	5733-EWA	5733-EWA
---	---	---	---	---	---	5733-EWM	5733-EWM
5798-TBY	*	*	*	5798-FAX	5798-FAX	*	*
---	---	---	---	---	5620-FIF	*	*
5769-FN1	*	*	*	*	*	*	*
5769-FNT	*	*	*	*	*	*	*
5769-FW1	*	5769-FW1	5769-FW1	N/A	N/A	N/A	N/A
---	---	5733-FXD	*	*	*	*	*
---	---	---	---	5639-F25	5639-F25	*	*
---	---	---	---	5697-G14	N/A	N/A	N/A
---	---	---	---	5697-G23	N/A	N/A	N/A
---	---	---	---	5697-G24	*	5724-E86	5724-E86

V4R2	V4R3	V4R4	V4R5	V5R1	V5R2	V5R3	V5R4
---	---	---	---	5697-G84	*	*	N/A
---	---	---	---	---	5697-G85	*	N/A
---	---	---	---	5733-ID1	*	*	*
---	---	---	---	5733-IM3	*	N/A	N/A
---	---	---	---	---	5698-ISE	*	N/A
---	---	---	---	5722-IP1	5722-IP1	5722-IP1	*
---	---	---	---	---	5722-IWE	N/A	N/A
---	---	5798-JC1	*	*	*	N/A	N/A
5769-JS1	5769-JS1	*	5769-JS1	5722-JS1	5722-JS1	5722-JS1	5722-JS1
---	---	---	---	---	1TME-LCF	*	*
---	---	---	---	---	5733-LD6	N/A	N/A
---	---	---	---	---	5733-LE1		N/A
---	---	5769-LNP	*	*	P/N	P/N	P/N
---	---	5769-LNT	*	*	P/N	P/N	P/N
5769-MG1	*	*	*	5722-MG1	5722-MG1	5722-MG1	5722-MG1
5769-PD1	*	*	*	5722-PD1	*	*	N/A
5769-PT1	*	5769-PT1	5769-PT1	5722-PT1	5722-PT1	5722-PT1	5722-PT1
---	---	5733-PY1	5733-PY2	*	5733-PY3	N/A	N/A
5716-QU1	5769-QU1	5769-QU1	5769-QU1	5722-QU1	5722-QU1	5722-QU1	5722-QU1
5769-RD1	*	5769-RD1	5769-RD1	5722-RD1	5722-RD1	P/N	P/N
N/A	N/A	N/A	N/A	N/A	N/A	5733-RDS	5733-RDS
5716-SM1	5769-SM1	5769-SM1	5769-SM1	5722-SM1	5722-SM1	5722-SM1	5722-SM1
5716-PM1	---	5769-PM1	*	5722-SS1	*	*	*
5769-SS1	*	*	*	5722-SS1	5722-SS1	5722-SS1	5722-SS1
5716-ST1	5769-ST1	5769-ST1	5769-ST1	5722-ST1	5722-ST1	5722-ST1	5722-ST1
5716-SV2	5769-SV3	*	*	N/A	N/A	N/A	N/A
---	5798-TBG	*	*	*	*	*	*
5716-VG1	*	*	5769-VG1	*	*	*	N/A
---	---	5733-A18	5769-VI1	5722-VI1	5722-VI1	P/N	P/N
---	5733-WA2	*	*	N/A	N/A	N/A	N/A
---	5733-WA3	*	*	*	5733-WA4	*	N/A
---	---	5798-WC4	*	*	N/A	N/A	N/A
---	---	5798-NC3	5798-WC5	*	N/A	N/A	N/A
5769-PW1	*	5769-PW1	5769-WDS	5722-WDS	5722-WDS	5722-WDS	5722-WDS
5769-CL3	*	5769-CL3	5769-WDS	5722-WDS	5722-WDS	5722-WDS	5722-WDS
5769-CX2	5769-CX2	5769-CX2	5769-WDS	5722-WDS	5722-WDS	5722-WDS	5722-WDS
5716-CX4*	*	*		Windows and CX5	5722-WDS	5722-WDS	5722-WDS
5769-CB1	*	*	5769-WDS	5722-WDS	5722-WDS	5722-WDS	5722-WDS
5716-CX5*	*	5769-CX5	5769-WDS	5722-WDS	5722-WDS	5722-WDS	5722-WDS
		5769-PW1	5769-WDS	5722-WDS	5722-WDS	5722-WDS	5722-WDS
5769-RG1	*	*	5769-WDS	5722-WDS	5722-WDS	5722-WDS	5722-WDS
---	---	---	---	---	5733-WS5	*	N/A
---	---	---	---	---	5733-XT1	5733-XT1	5733-XT1
5769-XW1	5769-XW1	5769-XW1	5769-XW1	5722-XW1	5722-XW1	5722-XW1	5722-XW1



HSL, SPCN, line cord, and communication cables for IBM System i5, eServer i5, and iSeries systems

This chapter has feature code descriptions for the HSL, SPCN (power), dual line cords, and communication cables used with the System i5, eServer i5, and iSeries servers.

11.1 HSL cables

Use the following tables as a reference for the HSL cables supported on the System i5, eServer i5, and iSeries servers. For more information use the following resources.

http://publib.boulder.ibm.com/infocenter/eserver/v1r2s/en_US/index.htm

http://www-1.ibm.com/servers/eserver/series/ha/pdf/HSL_rules_V5R3.pdf

Refer to the following publications for an explanation of HSL configuration rules and placement considerations:

- ▶ *IBM eServer iSeries Migration: A Guide to Upgrades and Migrations to POWER Technology, SG24-7200*

This redbook also contains configuration rules for eServer i5 Models and towers.

- ▶ *IBM eServer iSeries Migration: System Migration and Upgrades at V5R1 and V5R2, SG24-6055*

This redbook also contains configuration rules for iSeries models and towers.

- ▶ *IBM eServer i5 and iSeries System Handbook i5/OS Version 5 Release 3 October 2005 - Draft, GA19-5486*

- ▶ *High-speed Link Loop Architecture for the IBM eServer iSeries Server: OS/400 Version 5 Release 2, REDP-3652*

Cable feature	520	550	570	595	800 810	825	870/890
Copper							
#1307 1.75m Copper HSL-2 Cable	X ⁵	X	X	X		X	X
#1308 2.5m Copper HSL-2 Cable	X	X	X	X		X	X
#1460 3m Copper HSL Cable					X		
#1461 6m Copper HSL Cable					X		
#1474 6m HSL to HSL-2 Cable	X	X	X	X	X	X	X
#1475 10m HSL to HSL-2 Cable	X	X	X	X		X	X
#1481 1m HSL-2 Cable	X ⁵	X ⁵	X	X		X	
#1482 3.5m HSL-2 Cable	X	X	X	X	X ⁷	X	X
#1483 10m HSL-2 Cable	X	X	X	X		X	X
#1485 15m HSL-2 Cable ⁶	X	X	X	X		X	X
Fiber optic¹							
#1470 6m Optical HSL Cable		X	X	X		X	X
#1471 30m Optical HSL Cable		X	X	X		X	X
#1472 100m Optical HSL Cable		X	X	X		X	X
#1473 250m Optical HSL Cable		X	X	X		X	X
SPCN³							
#0369 100m Optical SPCN Cable ⁸		X	X	X		X	X
#1463 2m SPCN Cable	X	X	X	X	X	X	X
#1464 6m SPCN Cable	X	X	X	X	X	X	X

Cable feature	520	550	570	595	800 810	825	870/890
#1465 15m SPCN Cable	X	X	X	X	X	X	X
#1466 30m SPCN Cable	X	X	X	X	X	X	X
#1468 250m Optical SPCN Cable ⁹		X	X	X		X	X
#6001 Power Control Cable - 2M			X ⁴				
#6006 SPCN Power Cable 3m	X	X	X	X			
#6007 Power Control Cable - 15M	X	X	X	X			
#6008 Power Control Cable - 6M	X	X	X	X			
#6029 Power Control Cable - 30M	X	X	X	X			

¹ A fiber optic cable requires a base or feature optical HSL port card in the system.
³ Fiber optic SPCN cables include two copper to fiber adapter, p/n 90H6827.
⁴ Cannot be plugged into a rack mounted model 520.
⁵ Cannot be plugged into rack mounted Model 520 system unit.
⁶ Use when greater distance is required. Performance can be degraded.
⁷ Maximum of one when in a cluster environment
⁸ Cannot be directly attached to an SPCN port on a model 550 or 570 system unit. Can be attached to SPCN ports of I/O tower/drawers.
⁹ Cannot be directly attached to an SPCN port on a model 550, 570, or 595 system unit. Can be attached to SPCN ports of I/O tower/drawers.

Cable feature	#5074	#5079 #8079	IXA card	#5094 #9094	#5095 #0595	#5088 #0588	#5294 #8094	#5790
Copper								
#1307 1.75m Copper HSL-2 Cable				X	X ³	X ³	X	X
#1308 2.5m Copper HSL-2 Cable				X	X	X	X	X
#1460 3m Copper HSL Cable	X	X	X					
#1461 6m Copper HSL Cable	X	X	X					
#1462 15m Copper HSL Cable	X	X	X					
#1474 6m HSL to HSL-2 Cable	X	X	X	X	X	X	X	X
#1475 10m HSL to HSL-2 Cable	X	X	X	X	X	X	X	X
#1481 - 1 m HSL-2 Cable				X	X	X	X	X
#1482 3.5m HSL-2 Cable				X	X	X	X	X
#1483 10m HSL-2 Cable				X	X	X	X	X
#1485 15m HSL-2 Cable				X	X	X	X	X
Fiber optic¹								
#1470 6m Optical HSL Cable	X	X		X	X	X	X	
#1471 30m Optical HSL Cable	X	X		X	X	X	X	
#1472 100m Optical HSL Cable	X	X		X	X	X	X	
#1473 250m Optical HSL Cable	X	X		X	X	X	X	
SPCN^{2,4}								
#1463 2m SPCN Cable	X	X	X	X	X	X	X	X

Cable feature	#5074	#5079 #8079	IXA card	#5094 #9094	#5095 #0595	#5088 #0588	#5294 #8094	#5790
#1464 6m SPCN Cable	X	X	X	X	X	X	X	X
#1465 15m SPCN Cable	X	X	X	X	X	X	X	X
#1466 30m SPCN Cable	X	X	X	X	X	X	X	X
#1468 250m Optical SPCN Cable	X	X		X	X	X	X	
#0369 100m Optical SPCN Cable	X	X		X	X	X	X	
#6001 Power Control Cable - 2M	X	X	X	X ³	X ³	X ³	X	
#6006 SPCN Power Cable 3m	X	X	X	X	X	X	X	X
#6007 Power Control Cable - 15M	X	X	X	X	X	X	X	X
#6008 Power Control Cable - 6M	X	X	X	X	X	X	X	X
#6029 Power Control Cable - 30M	X	X	X	X	X	X	X	X

1. Optical cable requires a base or feature optical HSL port card in the tower.
2. Fiber optic SPCN cables include two copper to fiber adapter, p/n 90H6827.
3. Cannot be used on rack mounted towers.
4. On Models 520, 550, 570, and 595, SPCN cabling must be a single closed loop across all I/O towers/drawers.
5. Cannot be plugged into rack mounted Model 520 system unit.
6. Use when greater distance is required. Performance can be degraded.

11.1.1 HSL cable feature descriptions

HSL cables	
#1307	<p>#1307 - 1.75m Copper HSL-2 Cable The #1307 - 1.75m Copper HSL-2 Cable is used to connect HSL-2/RIO-G ports in towers and system units.</p> <p>Supported on Models 520, 550, 570, and 590 Not supported in rack-mounted 520 or 550 system units Minimum operating system level: i5/OS V5R3 The #1307 is a Customer Install Feature.</p>
#1308	<p>#1308 - 2.5m Copper HSL-2 Cable The #1308 - 2.5m Copper HSL-2 Cable is used to connect HSL-2/RIO-G ports in towers and system units.</p> <p>Supported on Models 520, 550, 570, and 595 Minimum operating system level: i5/OS V5R3 The #1308 is a Customer Install Feature.</p>
#1460	<p>#1460 - 3.0m Copper HSL Cable The #1460 - 3.0m HSL Cable is used to connect HSL ports in towers and system units.</p> <p>Some restrictions apply. On the Models 520, 550, 570, 595, 825, 870 and 890 this cable cannot be attached directly to any system port, (HSL-2) it can, however be used in between I/O expansion towers (HSL) which are attached to those systems via an HSL to HSL-2 adapter cable.</p> <p>Supported on Models 270, 520, 550, 570, 595, 800, 810, 825, 820, 830, 840, 870 and 890 Minimum operating system level: OS/400 V4R5 The #1460 is a Customer Install Feature.</p>

#1461	<p>#1461 - 6.0m Copper HSL Cable The #1461 - 6.0m HSL Cable is used to connect HSL ports in towers and system units.</p> <p>Some restrictions apply. On Models 520, 550, 570, 595, 825, 870 and 890 this cable cannot be attached directly to any system port, (HSL-2) it can, however be used in between I/O expansion towers (HSL) which are attached to those systems via an HSL to HSL-2 adapter cable.</p> <p>Supported on Models 270, 520, 550, 570, 595, 800, 810, 820, 830, 840 Minimum operating system level: OS/400 V4R5 The #1461 is a Customer Install Feature.</p>
#1462	<p>#1462 - 15.0m Copper HSL Cable The #1462 - 15.0m HSL Cable is used to connect HSL ports in towers and system units.</p> <p>Some restrictions apply. The #1462 cable cannot be attached to system port A1 of a Model 820 unless only a migration tower is connected. On the Models 270, 800, 810, the #1462 cable cannot be attached directly to any system port. It can be used to connect I/O expansion towers which are attached to those systems. On the models 520, 550, 570, 595, 825, 870 and 890, the #1462 cable cannot be attached directly to any system port. It can be used to connect I/O expansion towers (HSL) which are attached to those systems via an HSL to HSL-2 adapter cable.</p> <p>Supported on Models 270, 520, 550, 570, 595, 800, 810, 820, 830, 840 Minimum operating system level: OS/400 V4R5 The #1462 is a Customer Install Feature.</p>
#1470	<p>#1470 - 6.0m Optical HSL Cable The #1470 - 6.0m HSL cable is used to connect optical HSL ports in towers and system units.</p> <p>Supported on Models 550, 570, 595, 825, 830, 840, 870, 890 Minimum operating system level: OS/400 V5R1 The #1470 is a Customer Install Feature.</p>
#1471	<p>#1471 - 30.0m Optical HSL Cable The #1471 - 30.0m HSL cable is used to connect optical HSL ports in towers and system units.</p> <p>Supported on Models 550, 570, 595, 825, 830, 840, 870, 890 Minimum operating system level: OS/400 V5R1 The #1471 is a Customer Install Feature.</p>
#1472	<p>#1472 - 100.0m Optical HSL Cable The #1472 - 100.0m HSL cable is used to connect optical HSL ports in towers and system units.</p> <p>Supported on Models 550, 570, 595, 825, 830, 840, 870, 890 Minimum operating system level: OS/400 V5R1 The #1472 is a Customer Install Feature.</p>
#1473	<p>#1473 - 250.0m Optical HSL Cable The #1473 - 250.0m HSL cable is used to connect optical HSL ports in towers and system units.</p> <p>Supported on Models 550, 570, 595, 825, 830, 840, 870, 890 Minimum operating system level: OS/400 V5R1 The #1473 is a Customer Install Feature.</p>
#1474	<p>#1474 - 6m HSL to HSL-2 Cable The #1474 - 6m HSL to HSL-2 Cable is used to connect HSL and HSL-2/RIO-G ports in towers and system units.</p> <p>Supported on Models 520, 550, 570, 595, 800, 810, 820, 825, 830, 840, 870, and 890 Minimum operating system level: i5/OS V5R3 The #1474 is a Customer Install Feature.</p>
#1475	<p>#1475 - 10m HSL to HSL-2 Cable The #1475 - 10m HSL to HSL-2 Cable is used to connect HSL and HSL-2/RIO-G ports in towers and system units.</p> <p>Supported on Models 520, 550, 570, 595, 800, 810, 820, 825, 830, 840, 870, and 890 Minimum operating system level: i5/OS V5R3 The #1475 is a Customer Install Feature.</p>

#1481	<p>#1481 - 1.2m HSL-2 Cable The #1481 - 1.2m HSL-2 Cable is used to connect HSL-2/RIO-G ports in towers and system units.</p> <p>Supported on Models 520, 550, 570, and 595 Minimum operating system level: i5/OS V5R3 The #1481 is a Customer Install Feature.</p>
#1482	<p>#1482 - 3.5m HSL-2 Cable The #1482 - 3.5m HSL-2 Cable is used to connect HSL-2/RIO-G ports in towers and system units.</p> <p>Supported on Models 520, 550, 570, 595, 800, 810, 820, 825, 830, 840, 870, and 890 Minimum operating system level: i5/OS V5R3 The #1482 is a Customer Install Feature.</p>
#1483	<p>#1483 - 10m HSL-2 Cable The #1483 - 10m HSL-2 Cable is used to connect HSL-2/RIO-G ports in towers and system units.</p> <p>Supported on Models 520, 550, 570, 595, 800, 810, 820, 825, 830, 840, 870, and 890 Minimum operating system level: i5/OS V5R3 The #1483 is a Customer Install Feature.</p>
#1485	<p>#1485 - 15.0m Copper HSL-2 Cable The #1485 - 15m HSL-2 Cable is used to connect HSL-2/RIO-G ports in towers and system units.</p> <p>Some restrictions apply. On the models 800, 810 this cable cannot be attached directly to any system port, it can however be used in between I/O Expansion towers which are attached to those systems.</p> <p>Supported on Models 520, 550, 570, 595, 800, 810, 820, 825, 830, 840, 870, and 890 Minimum operating system level: i5/OS V5R3 The #1485 is a Customer Install Feature.</p>
#1487	<p>#1487 - 3m HSL to HSL-2 Cable The #1487 - 3m HSL/RIO to HSL-2/RIO-G Cable is used to connect a tower and system unit with an HSL/RIO port to a tower and system unit with an HSL-2/RIO-G port.</p> <p>Supported on Models 520, 550, 570, 595, 800, 810, 825, 870, and 890 Minimum operating system level: i5/OS V5R3 The #1487 is a Customer Install Feature.</p>

11.2 SPCN (power) cables

Use the following table as a reference for the power cords supported on System i5, eServer i5, iSeries and AS/400e systems. For more information use the following online resource.

http://publib.boulder.ibm.com/infocenter/eserver/v1r2s/en_US/index.htm

SPCN cables	
#6001	<p>#6001 Power Control Cable - 2M The #6001 is a 2m SPCN Power Control Cable. The #6001 cannot be connected to a rack mounted Model 520, 550, or 595. The #6001 is a Customer Install Feature.</p>
#6006	<p>#6006 Power Control Cable - 3M The #6006 is a 3m SPCN Power Control Cable. The #6006 is a Customer Install Feature.</p>
#6007	<p>#6007 Power Control Cable - 15M The #6007 is a 15m SPCN Power Control Cable. The #6007 is a Customer Install Feature.</p>
#6008	<p>#6008 Power Control Cable - 6M The #6008 is a 6m SPCN Power Control Cable. The #6008 is a Customer Install Feature.</p>

#6029	<p>#6029 Power Control Cable - 30M The #6029 is a 30m SPCN Power Control Cable. The #6029 is a Customer Install Feature.</p>
Special Power and Control Cables	
#1422	<p>#1422 PDU Line Cord The #1422 PDU Line Cord is used from a rack-mounted device to a #5160/#5161/#5162/#5163/#7188 Power Distribution Unit in that same rack.</p> <p>Supported on Models 520, 550, 570, 595, 800, 810, 820, 825, 830, 840, 870, 890, and #0578, #0595, #7104 and #7188 expansion units Minimum operating system level: OS/400 V5R1 The #1422 is a Customer Install Feature.</p>
#1827	<p>#1827 Serial-UPS Conversion Cable The #1827 is a 0.14M adapter cable with a female 9-pin D-shell connector on each end. The #1827 converts the system unit system port 2 to a SPCN/UPS port, providing an additional port for uninterruptible power supply control. The mode of the port cannot be changed during runtime. A re-IPL is required to change the mode when the adapter cable is connected or disconnected.</p> <p>An #1827 Serial-UPS Conversion Cable is required to provide uninterruptible power supply control and feedback information for the Models 520, 550, and 570. This does not impact the ability of the uninterruptible power supply to provide power in case of an outage. Its presence enables the uninterruptible power supply for alerting the Model 520, 550, and 570 that it is under uninterruptible power supply power and advising the server of the amount of remaining uninterruptible power supply battery power.</p> <p>The eServer i5 servers use a different physical port to attach the uninterruptible power supply communications control cable. It is not the J14 port, which was used by previous iSeries servers. This applies to any uninterruptible power supply which needs to provide control information to the eServer i5 port.</p> <p>The #1827 Serial-UPS conversion cable attaches to one of the system ports on the back of Models 520, 550, and 570 and to the previously existing control cable provided with the uninterruptible power supply.</p> <p>Supported on Models 520, 550, and 570 Minimum operating system level: The latest level of Model 520, 550, and 570 Licensed Internal Code (LIC) is required for full uninterruptible power supply communications capability.</p>
#6458	<p>#6458 PDU Power Cord (250V/10a 3m) The #6458 PDU Power Cord is used from a rack-mounted device to a #5160, #5161, #5162, #5163 or #7188 PDUs in the same rack. Supported with Models 520, 550, 570 and 595 and the 7310-CR2 rack mounted HMC Minimum operating system level: i5/OS V5R3</p>

11.3 Dual line cords

Use the following table as a reference for the dual line cords supported on System i5, eServer i5, or iSeries systems. For more Information use the following online resource:

http://publib.boulder.ibm.com/infocenter/eserver/v1r2s/en_US/index.htm

Dual line cords	
#5105	<p>#5105 Dual Line Cords - I/O Tower The #5105 Dual Line Cords - I/O Tower provides dual line cord capability for a #5079 and top unit in an #8079 Optional Base 1.8 M I/O Rack or #8093 Optional 1.8 M I/O Rack. Two #14xx line cords must be ordered for each #5074 PCI Expansion Tower with a #5105 when a #5105 is ordered on an initial order of a #5074. When ordering a #5105 as an MES, against an existing #5074, one additional #14xx line cord is required to be ordered (for a total of two line cords for a #5074).</p> <p>A #5074 mounted in a #0551 iSeries Rack is supported with the #5105. Convert any #5101 30 Disk Unit Expansion features installed in the #5074 to #5111 30 Disk Expansion with Dual Line Cords features. No parts are shipped. Supported on standalone #5074 or the top unit in a #8079 Minimum operating system level: OS/400 V5R1</p>

#5106	<p>#5106 Dual Line Cords - #5079 Tower The #5106 Dual Line Cords - #5079 Tower provides dual line cord capability for a single unit in a #5079 1.8 M I/O Tower. Two #14xx line cords must be ordered for each #5106 present, when a #5106 is ordered on an initial order of a #5079. When ordering a #5106 as an MES, against an existing #5079, one additional #14xx line cord is required to be ordered for each #5106 ordered. The IBM marketing configurator defaults a quantity of two #5106s, for each #5079 ordered, on a system that has dual line cords on the system unit. Convert any #5101 30 Disk Unit Expansion features installed in the #5079 to #5111 30 Disk Expansion with Dual Line Cords features. No parts are shipped. Minimum operating system level: OS/400 V5R1</p>
#5114	<p>#5114 Dual Line Cords Tower The #5114 Dual Line Cords Tower provides dual line cord capability for the #9094 Base PCI I/O Enclosure and the lower unit in an #8093 Optional 1.8 M I/O Rack/#8094 Optional 1.8 M I/O Rack. Two #14xx line cords must be ordered on an initial order or a model upgrade into an 890 from a non-890 model. When ordering a #5114 as an MES, one additional #14x line cord is required to be ordered. One 840W power supply is shipped. The #5114 has country-specific or region-specific usage. Minimum operating system level: OS/400 V5R2</p>
#5115	<p>#5115 Dual Line Cords Tower The #5115 Dual Line Cords Tower is a dual line cord enabler for the upper unit in an #8094 Optional 1.8 M I/O Rack and for the #5094 PCI-X Expansion Tower. One 840W power supply is shipped. A second line cord must be ordered for each tower installing a #5115. Maximum: One #5115 per #5094 PCI-X Expansion Tower and one per top unit of an #8094 Optional 1.8 M I/O Rack Minimum operating system level: OS/400 V5R2</p>
#5116	<p>#5116 Dual Line Cords - #5294 The #5116 Dual Line Cords - #5294 provides dual line cord capability for a single unit in a #5294 1.8m I/O Tower. Two line cords are required for each #5116 present. One 840W power supply is shipped. The IBM marketing configurator defaults a quantity of two #5116s for each #5294 ordered on a system that has dual line cords on the system unit. Minimum operating system level: OS/400 V5R2</p>
#5164	<p>#5164 Dual Power Cords - #8294/#9194 The #5164 provides dual line cord capability for the #9194 Base PCI-X Expansion Tower and the lower enclosure in the #8294 Optional Base 1.8m Rack. An additional line cord must be specified if #5164 is ordered on the #9194/#8294. When ordering a #5164 for an installed #9194/#8294, an additional line cord must also be ordered. The configurator defaults to a #5164 if the #9194/#8294 is ordered on a system that has dual line cords on the system unit. Plugging in the second line cord, even if to the same outlet, enables the AC power modules to be redundant. A #9194 Base PCI-X Expansion Tower or #8294 Optional Base 1.8m Rack is required. Initial order or MES supported Supported on Model 595 attached towers Minimum operating system level: i5/OS V5R3 The #5164 is an IBM Service Representative setup feature.</p>
#5165	<p>#5165 Dual Power Cords - #8294 The #5165 provides dual line cord capability for the upper enclosure in the #8294 Optional Base 1.8m Rack. An additional line cord must be specified if #5165 is ordered on the #8294. When ordering a #5165 for an installed #8294, an additional line cord must also be ordered. The configurator defaults to a #5165 if the #8294 is ordered on a system that has dual line cords on the system unit. Plugging in the second line cord, even if to the same outlet, enables the AC power modules to be redundant. A #8294 Optional Base 1.8m Rack is required. Initial order or MES Supported on Model 595 attached towers Minimum operating system level: i5/OS V5R3 The #5165 is an IBM Service Representative setup feature.</p>

11.4 Communication cables

Use the following part numbers to order cables for the System i5, eServer i5, and iSeries models. The following part numbers might not be available in all countries or regions, or on all models and can change.

Description	Length	Part number	Feature code
SPD communication cables non-enhanced			
RS232 Cable	6.1m (20 ft)	22F0149	#9022
RS232 Cable - Germany	6.1m (20 ft)	22F0150	#9022
RS232 Cable - Japan	6.1m (20 ft)	22F0151	#9022
RS232 Cable	15.2m (50 ft)	22F9348	#9836
RS232 Cable - Germany	15.2m (50 ft)	21F9953	#9836
RS232 Cable - Japan	15.2m (50 ft)	21F9349	#9836
RS366 Cable	6.1m (20 ft)	72X5643	#9840
RS366 Cable - Japan	6.1m (20 ft)	21F4415	#9840
SPD communication cables enhanced			
V.24 Cable	6.1m (20 ft)	22F0152	#9023
V.24 Cable - Germany	6.1m (20 ft)	22F0153	#9023
V.24 Cable - Japan	6.1m (20 ft)	22F0154	#9023
V.24 Cable	15.2m (50 ft)	21F9350	#9835
V.24 Cable - Germany	15.2m (50 ft)	21F9352	#9835
V.24 Cable - Japan	15.2m (50 ft)	21F9351	#9835
V.24 Cable	24.2m (80 ft)	74F1837	#9869
Other SPD communication cables			
V.35 Cable	6.1m (20 ft)	72X5641	#9020
V.35 Cable	15.2m (50 ft)	21F9357	#9838
V.35 Cable	24.4m (80 ft)	74F1839	#9870
X.21 Cable	6.1m (20 ft)	72X5640	#9021
X.21 Cable	15.2m (50 ft)	21F9356	#9839
2 Port Communication Cable	3m (10 ft)	21F9345	#9843
#2666 High-Speed Communications Adapter (SPD)			
RS449 Cable	6.1m (20 ft)	17G4000	#9882
RS449 Cable	24.4m (80 ft)	17G4001	#9883
RS449 Cable	45.7m (150 ft)	17G4002	#9884
V.35 Cable	6.1m (20 ft)	17G3991	#9879
V.35 Cable	24.4m (80 ft)	17G3992	#9880
X.21 Cable	6.1m (20 ft)	17G3987	#9885
PCI/SPD miscellaneous server cables			
BBU Cable	2.4m (8 ft)	86G7712	#5144
Diskette Cable	2.4m (8 ft)	46G3658	#9886
Diskette/Twinaxial Cable	2.4m (8 ft)	46G3585	#9887
Ethernet Cable	3.0m (10 ft)	86G7691	#9025
Token Ring Cable	2.4m (8 ft)	6339098	#9024

PCI Communication Cables for Models 150, 600, S10, 620, S20, 720, 250, 270, 820, 830, SB2, 840, SB3, and 890			
RS232 Cable	6.1m (20 ft)	44H7480	#0348
RS232 Cable - Germany	6.1m (20 ft)	44H7482	#0348
RS232 Cable - Japan	6.1m (20 ft)	44H7484	#0348
V.24 Cable	6.1m (20 ft)	44H7486	#0350
V.24 Cable	6.1m (20 ft)	44H7489	#0350
V.24 Cable	6.1m (20 ft)	44H7492	#0350
V.35 Cable	6.1m (20 ft)	44H7495	#0353
V.36 Cable	6.1m (20 ft)	44H7498	#0356
X.21 Cable	6.1m (20 ft)	44H7501	#0359
Client Access Console Cable	6.1m (20 ft)	44H7504	#0362
Operations Console Cable	6.1m (20 ft)	97H7557	#0367
Remote Control Panel Cable	6.1m (20 ft)	97H7591	#0381
PCI Communication Cables for Models 170, 600, S10, 620, S20, 720, 250, 270, 820, 830, SB2, 840, SB3, and 890			
RS232 Cable	15.2m (50 ft)	44H7481	#0349
RS232 Cable - Germany	15.2m (50 ft)	44H7483	#0349
RS232 Cable - Japan	15.2m (50 ft)	44H7485	#0349
V.24 Cable	15.2m (50 ft)	44H7487	#0351
V.24 Cable - Germany	15.2m (50 ft)	44H7490	#0351
V.24 Cable - Japan	15.2m (50 ft)	44H7493	#0351
V.24 Cable	24.4m (80 ft)	44H7488	#0352
V.24 Cable - Germany	24.4m (80 ft)	44H7491	#0352
V.24 Cable - Japan	24.4m (80 ft)	44H7494	#0352
V.24 Cable	24.4m (80 ft)	97H7386	#0365
V.24 Cable - Germany	24.4m (80 ft)	97H7387	#0365
V.24 Cable - Japan	24.4m (80 ft)	97H7388	#0365
V.35 Cable	15.2m (50 ft)	44H7496	#0354
V.35 Cable	24.4m (80 ft)	44H7497	#0355
V.36 Cable	15.2m (50 ft)	44H7499	#0357
V.36 Cable	45.7m (150 ft)	44H7500	#0358
X.21 Cable	15.2m (50 ft)	44H7502	#0360

SPD Communication Cables for Models 600, 620, 640, 650, S10, S20, S30, S40 and SB1			
RS232 Cable	6.1m (20 ft)	21H3764	#0330
RS232 Cable - Germany	6.1m (20 ft)	21H3765	#0330
RS232 Cable - Japan	6.1m (20 ft)	21H3766	#0330
RS232 Cable	15.2m (50 ft)	21H3767	#0331
RS232 Cable - Germany	15.2m (50 ft)	21H3768	#0331
RS232 Cable - Japan	15.2m (50 ft)	21H3769	#0331
V.24 Cable	6.1m (20 ft)	21H3770	#0332
V.24 Cable - Germany	6.1m (20 ft)	21H3771	#0332
V.24 Cable - Japan	6.1m (20 ft)	21H3772	#0332
V.24 Cable	15.2m (50 ft)	21H3773	#0333
V.24 Cable - Germany	15.2m (50 ft)	21H3774	#0333
V.24 Cable - Japan	15.2m (50 ft)	21H3775	#0333
V.24 Cable	24.4m (80 ft)	21H3776	#0334
V.24 Cable - Germany	24.4m (80 ft)	21H3777	#0334
V.24 Cable - Japan	24.4m (80 ft)	21H3778	#0334
V.35 Cable	6.1m (20 ft)	21H3787	#0335
V.35 Cable	15.2m (50 ft)	21H3788	#0336
V.35 Cable	45.7m (150 ft)	21H3789	#0337
V.36 Cable	6.1m (20 ft)	21H3783	#0341
V.36 Cable	6.1m (20 ft)	21H3792	#0338
V.36 Cable	15.2m (50 ft)	21H3785	#0339
X.21 Cable	24.4m (80 ft)	21H3786	#0340
X.21 Cable	15.2m (50 ft)	21H3779	#0342
Client Access Console Cable	6.1m (20 ft)	21H3782	#0344
Operations Console Cable	6.1m (20 ft)	97H7556	#0328
Remote Control Panel Cable	6.1m (20 ft)	97H7584	#0380
Client Access Console Cable	6m (20 ft)	46G0450	#9026
Client Access Console Cable	2.5m (8 ft)	46G0479	#9027

Modem (telephone) Cables for #9771 Base PCI Two-Line WAN with integrated modem, #2761 Integrated Analog Modem, and #4761 PCI Integrated Analog Modems			
Modem Cable - Africa	9.1m (30 ft)	21H4904	#1012
Modem Cable - Australia	9.1m (30 ft)	75G3807	#1019
Modem Cable - Austria	9.1m (30 ft)	21H4902	#1010
Modem Cable - Belgium	9.1m (30 ft)	21H4903	#1011
Modem Cable - Denmark	9.1m (30 ft)	75G3812	#1024
Modem Cable - Finland/Norway	9.1m (30 ft)	75G3809	#1021
Modem Cable - France	9.1m (30 ft)	75G3803	#1015
Modem Cable - Germany	9.1m (30 ft)	75G3804	#1016
Modem Cable - China (Hong Kong S.A.R.)/New Zealand	9.1m (30 ft)	75G3808	#1020
Modem Cable - Iceland/Sweden	9.1m (30 ft)	87G6236	#1018
Modem Cable - Israel	9.1m (30 ft)	21H4905	#1013
Modem Cable - Italy	9.1m (30 ft)	75G3802	#1014
Modem Cable - Netherlands	9.1m (30 ft)	75G3810	#1022
Modem Cable - Switzerland	9.1m (30 ft)	75G3811	#1023
Modem Cable - United Kingdom	9.1m (30 ft)	75G3805	#1017
Modem Cable - U.S./Canada	9.1m (30 ft)	787G623	#1025

For a complete list of System i cables, see the iSeries Information Center at:

<http://publib.boulder.ibm.com/series/>

After you reach the Information Center, on the left panel, click the **IBM Systems Hardware Information** option. Then on the left panel click the **IBM Systems Hardware Information** option again. Then under Planning click the **Plan for cables** page, scroll down and click the **All cables** link.

Archived

Summary of AS/400 CISC models

This chapter provides the capacity charts that indicate the minimum and maximum configurations of CISC models of the AS/400.

For detailed information about CISC features and models, see *AS/400 CISC System Builder*, REDP-0042. You can find a summary of RISC models in Chapter 13, “Summary of AS/400e RISC models” on page 407, as well as in *IBM eServer AS/400e RISC System Builder Version 3 Release 6 - Version 5 Release 2*, REDP-0342.

Note: OS/400 V1R2 through V3R2 support CISC systems.

The following table represents the general availability and end-of-marketing dates for AS/400 CISC models.

Model	General availability	Withdrawn from marketing
Bxx	26 August 1988	03 December 1991
Cxx	23 February 1990	03 December 1991
Dxx	24 May 1991	19 August 1992
Exx	06 March 1992	03 May 1994
Fxx	05 March 1993	30 June 1996
2xx/3xx	03 June 1994	04 November 1997

Note: You can find footnotes for each of the table entries in 12.7, “Notes for all CISC system summary tables” on page 405.

12.1 AS/400 Model P02, P03, and 10S capacities

The 9401 Model P02, P03, and 10S systems minimum and maximum capacity tables are provided in the following sections.

12.1.1 Model P02 capacities

Feature	Processor	Minimum	Maximum
Relative system performance (RAMP-C) ²		2.5	2.5
Main storage (MB)		8	16
Disk storage (GB)		1.03	2.06
Twinaxial devices		1	7
Communication lines		1	1
Optional external tapes		1	1

12.1.2 Model P03 and 10S capacities

Model	P03								10S
	T01 (#0101)	T02 (#0102)	T03 (#0108)	T11 (#0124)	T12 (#0144)	L01 (#0103)	L02 (#0104)	L03 (#0109)	S01 (#0105)
Relative system performance (CPW) ¹	7.3	9.6	16.8	9.6	7.3	7.3	9.6	16.8	5.5/17.1 ⁵
Relative system performance (RAMP-C) ²	2.5	3.3	3.9	3.3	2.5	2.5	3.3	3.9	1.9/5.9 ⁵
Main storage (MB)	8-24	8-40	8-56	8-40	8-24	8-24	8-40	8-56	8-56
Disk storage (MB)	1.03-299	1.96-3.93	1.96-3.93	1.03-2.99	1.96-3.93	1.03-2.99	1.96-3.93	1.96-3.93	1.96-3.93
Communication lines	1	2	2	2	1	2 ¹²	2 ¹²	2 ¹²	2 ¹²
LAN adapters	-	-	-	-	-	1	1	1	1
Maximum workstations (one minimum)									
Twinaxial	7	14	14	14	7	-	-	-	-
LAN attached	-	-	-	-	-	16	16	16	16
840 MB ¼-inch crtrdg tape									
Internal	1	1	1	1	1	1	1	1	1
External	1	1	1	1	1	1	1	1	1
3450 ¼-inch cartridge	1	1	1	1	1	1	1	1	1

12.2 AS/400 Model Y10, 236, and 436 capacities

The 9402 Model Y10, 236 and 436 systems minimum and maximum capacities tables are provided in the following sections.

12.2.1 Model Y10 capacities

Feature	Processor	9402 Y10
Main storage (MB)		1-2
Disk storage (MB)		160-760
Diskette unit		1
Tape (¼-inch cartridge)		0-1
Communication lines		0-3
LAN adapters		0-1

12.2.2 Model 236 and 436 capacities

Feature	Processor	236			436 SSP only			436 SSP and OS/400		
		#2100	#2102	#2104	#2106	#2102	#2104	#2106		
Relative system performance (RAMP-C) ⁴		1.0	1.0	1.3	2.4	4.8	6.1	8.7		
Relative system performance (CPW V3R6) ¹		2	2	2	2	14.4	18.3	24.5		
Relative system performance (CPW V3R7/V4R1/V4R2/V4R3) ¹		2	2	2	2	16.3	20.6	27.4		
Main storage (MB)		32-96	32-224	32-224	32-256	64-224	64-224	64-256		

Disk storage (GB)			
SSP	1.03-4.1	1.03-4.12 ⁸	-
V3R6	2	-	1.96-236
V3R7 or higher	-	-	1.96-50.3
Feature card slots	6	6	6
Communication lines	1-8	1-8	1-20
LAN adapters ¹¹	0-2	0-2	0-2
ATM adapters	0	0	0-1
Maximum workstation controllers	2	4	7
Twinaxial	2	4	7
ASCII	0	0	6
LocalTalk	0	0	0
Maximum workstations (1 minimum)			
Twinaxial	80	160	280
ASCII	0	0	108
LocalTalk	0	0	0
¼-inch/8 mm cartridge tape (internal)	1	1	1-4
½-inch tape (external)			
9348	0-2	0-2	0-4
34xx/35xx	0	0	0-2
8 mm cartridge tape (external)	0	0	0-4
Tape libraries	0	0	0-2
Optical libraries	0	0	0-4
Diskette drives (5 ¼-inch or 8-inch)	0-1	0-1	0-2
Fax adapters	0	0	0-6
Cryptographic processors	0	0	0-1
System I/O buses	1	1	1

12.2.3 Model 436 package capacities

Feature	Package name	Entry #0114 ⁷	Growth #0115 ⁷	Large #0116 ⁷
Relative system performance (CPW V3R6) ¹		14.4-24.5	14.4-24.5	14.4-24.5
Relative system performance (CPW V3R7, V4R1, V4R2, or V4R3) ¹		16.3-27.4	16.3-27.4	16.3-27.4
Relative system performance (RAMP-C OS/400) ²		4.8-8.7	4.8-8.7	4.8-8.7
Relative system performance (RAMP-C SSP) ⁶		1.0-2.4	1.0-2.4	1.0-2.4
Main storage (MB)		32-256	32-256	64-256
Disk storage (GB) ⁹		1.03-23.6	1.96-23.6	3.93-23.6
Standard tape		¼-inch cartridge	¼-inch cartridge	¼-inch cartridge
Twinaxial devices		40-280	40-280	80-280
LAN adapters ¹¹		0-2	0-2	0-2
Communication lines		1-20	2-20	2-20

12.3 AS/400 Model C, D, E, and F capacities

The 9402 Model C, D, E, and F systems minimum and maximum capacity tables are provided in the following sections.

12.3.1 Model C and D capacities

Feature	Processor	C04	C06	D02	D04	D06
Relative system performance (CPW) ¹		3.1	3.6	3.8	4.4	5.5
Relative system performance (RAMP-C) ²		1.1	1.3	1.3	1.5	1.9
Main storage (MB)		8-12	8-16	8-16	8-16	8-20
Disk storage (MB)		640-1280	640-1280	800-1200	800-1600	800-1600
Maximum feature card slots		3	3	1	3	3
Communication lines		1-5	1-5	0-3	1-8	1-8
LAN adapters		0-1	0-1	0-1	0-1	0-1
Maximum workstation controllers		1	2	1	2	2
Twinaxial		1	2	1	2	2
ASCII		1	2	1	2	2
LocalTalk		0	0	1	1	1
Maximum workstations (one minimum)						
Twinaxial		14	54	14	28	54
ASCII		6	24	12	12	24
LocalTalk		0	0	31	31	31
¼-inch cartridge tape		1	1	1	1	1
½-inch reel tape		0-1	0-1	0	0-1	0-1
½-inch cartridge tape		0	0	0	0	0
8 mm cartridge tape		0	0	0	0-2	0-2
Tape libraries		0	0	0	0-1	0-1
Optical libraries		0	0	0	0-1	0-1
Diskette drives (5 ¼-inch or 8-inch)		0-1	0-1	0-1	0-1	0-1
Fax adapters		0	0	0	0-2	0-3
Cryptographic processors		0	0	0	0-1	0-1
System I/O buses		1	1	1	1	1

12.3.2 Model E and F capacities

Processor	E02	E04	E06	F02	F04	F06
Feature						
Relative system performance (CPW) ¹	4.5	5.5	7.3	5.5	7.3	9.6
Relative system performance (RAMP-C) ²	1.5	1.9	2.6	1.9	2.5	3.3
Main storage (MB)	8-24	8-24	8-40	8-24	8-24	8-40
Disk storage (MB)	988-2019	988-4081	988-4081	1031-2062	1031-4124	1031-8248
Maximum feature card slots	1	3	7	1	3	7
Communication lines	0-3	1-8	1-14	0-8	1-8	1-14
LAN adapters	0-1	0-1	0-2	0-1	0-1	0-2
Maximum workstation controllers	1	3	4	2	4	6
Twinaxial	1	2	2	2	2	3
ASCII	1	3	4	2	4	6
Local Talk	1	1	2	2	2	3
Maximum workstations (one minimum)						
Twinaxial	14	42	68	28	68	108
ASCII	12	48	66	18	66	102
LocalTalk	31	31	62	31	62	93
¼-inch cartridge tape	1	1	1-2	1	1	1-2
½-inch reel tape	0	0-1	0-2	0-1	0-1	0-2
½-inch cartridge tape	0	0	0	0	0	0
8 mm cartridge tape	0	0-2	0-4	0-2	0-2	0-4
Tape libraries	0	0-1	0-2	0-1	0-1	0-2
Optical libraries	0	0-1	0-2	0-1	0-1	0-2
Diskette drives (5¼-inch or 8-inch)	0-1	0-1	0-1	0-1	0-1	0-1
Fax adapters	0	0-2	0-3	0-1	0-2	0-3
Cryptographic processors	0	0-1	0-1	0-1	0-1	0-1
System I/O buses	1	1	2	1	1	2

12.4 AS/400 Model 200, 20S, 1xx, and 3xS capacities

The 9402 Model 200 and 20S, and the 9402, 9404 and 9406 Model 1xx, 20S and 3xS system minimum and maximum capacity tables are provided in the following sections.

12.4.1 Model 1xx, 20S, and 3xS capacities

Feature	Processor	9402 100	9404 135	9404 140	9402 20S	9406 30S	9406 30S
					#2010	#2411	#2412
Relative system performance (CPW) ¹							
Client/server environment		17.1	32.3	65.6	17.1	32.3	68.5
Interactive environment		5.5	9.6	11.6	5.5	9.6	11.6
Relative system performance (RAMP-C) ²							
Client/server environment		5.9	10.9	22.5	5.9	10.9	23.5
Interactive environment		1.9	3.3	4.0	1.9	3.3	4.0
Number of n-way multiprocessors		1	1	2	1	1	2
Main storage (MB)		16-56	32-384	64-512	16-128	32-384	64-832
Disk storage (GB)		1.03-8.2	1.03-27.5	1.03-86.5	1.03-23.6	1.03-86.5	1.03-86.5
Maximum feature card slot		6	6	21	5	64	114
Communication lines		1-8	1-14	1-20	1-20	1-33	1-33
LAN adapters		1-2	1-4	1-6	1-2	1-8	1-8
Maximum workstation controllers							
Twinaxial		1	1	1	1	1	1
ASCII		1	1	1	1	1	1
LocalTalk		1	2	2	1	2	2
Maximum workstations (one minimum)							
Twinaxial		7	7	7	7	7	7
ASCII		6	6	6	6	6	6
LocalTalk devices		31	62	62	31	62	62
¼-inch cartridge tape/8 mm cartridge tape (internal)		1-2	1-2	1-3	0-4	0-5	0-5
½-inch tape (external)							
9348/2440 (The 2440 is not supported by the Model 100 or 20S)		0-2	0-4	0-4	0-4	0-4	0-4
34xx/35xx		0	0-2	0-2	0-2	0-2	0-2
8 mm cartridge tape (external)		0-4	0-4	0-4	0-4	0-4	0-4
Tape libraries		0	0	0	0-2	0-2	0-2
Optical libraries		0-1	0-6	0-10	0-4	0-10	0-10
Diskette drives (5 ¼-inch or 8-inch)		0-1	0-2	0-2	0-2	0-2	0-2
Fax adapters		0-3	0-6	0-10	0-6	0-16	0-16
Cryptographic processors		0-1	0-1	0-1	0-1	0-1	0-1
System I/O buses		1-2	1-2	1-5	1	1-3	1-5

12.4.2 Model 200 capacities

Feature	Processor	200		
		#2030	#2031	#2032
Relative system performance (CPW) ¹		7.3	11.6	16.8
Relative system performance (RAMP-C) ²		2.5	4.0	6.2
Main storage (MB)		8-24	8-56	16-128
Disk storage (GB)			1.03-23.6	
(V3R1/R6)			1.03-50.3	
(V3R2/R7, V4R1/R2/R3)			6	
Maximum feature card slots			1-20	
Communication lines			0-2	
LAN adapters			0	
ATM adapters			7	
Maximum workstation controllers			7	
Twinaxial			7	
ASCII			7	
LocalTalk			7	
Maximum workstations			280	
Twinaxial			126	
ASCII			217	
LocalTalk			0-4	
¼-inch/8 mm cartridge tape (internal)			0-4	
½-inch tape (external)				
9348			0-4	
34xx/35xx			0-2	
8 mm cartridge tape (external)			0-4	
Tape libraries			0-2	
Optical libraries			0-4	
Diskette drives (5 ¼-inch or 8-inch)			0-2	
Fax adapters			0-6	
Cryptographic processors			0-1	
System I/O buses			1	

12.4.3 Model 20S package capacities

Feature	Package name	Twinaxial server 2FS	LAN server 2FS	Starter server 2SS	Growth server 2SG
Relative system performance (CPW) ¹					
Client/server environment		17.1	17.1	17.1	17.1
Interactive environment		5.5	5.5	5.5	5.5
Relative system performance (RAMP-C) ²					
Client/server environment		5.9	5.9	5.9	5.9
Interactive environment		1.9	1.9	1.9	1.9
Main disk storage (MB)		16-128	16-128	16-128	16-128
Disk storage (GB)		1.96-7.84	1.96-7.84	1.96-7.84	1.96-7.84
Standard tape		¼-inch cartridge	¼-inch cartridge	¼-inch cartridge	¼-inch cartridge
Twinaxial devices		7	0	0	0
LAN adapters		1-2	1-2	1	1
Communication lines ¹⁴		1-3	1-2	1-2	1-2

12.5 AS/400 Model B, C, D, E, and F capacities

The 9404 Model B, C, D, E, and F systems minimum and maximum capacity tables are provided in the following sections.

12.5.1 Model B and C capacities

Feature	Processor	B10	B20	C10	C20	C25
Relative system performance (CPW) ¹		2.9	5.1	3.9	5.3	6.1
Relative system performance (RAMP-C) ²		1.0	1.7	1.3	1.8	2.2
Main storage (MB)		4-16	4-28	8-20	8-32	8-40
Disk storage (MB)		630-2400	630-4800	640-2400	640-4800	640-6400
Maximum feature card slots		4	9	4	9	9
Communication lines		1-8	1-14	1-8	1-14	1-14
LAN adapters		0-1	0-2	0-1	0-2	0-2
Workstation controllers						
Twinaxial		1	2	1	2	2
ASCII		2	4	2	4	4
Maximum workstations (one minimum)						
Twinaxial		40	80	40	80	80
ASCII		36	72	36	72	72
½-inch cartridge tape		1	1-2	1	1-2	1-2
¼-inch reel tape		0-1	0-1	0-1	0-1	0-1
¼-inch cartridge tape		0-1	0-1	0-1	0-1	0-1
8 mm cartridge tape		0-2	0-2	0-2	0-4	0-4
Tape libraries		0-1	0-2	0-1	0-2	0-2
Optical libraries		0	0	0	0	0
Diskette drives (5 ¼-inch or 8-inch)		0-1	0-2	0-1	0-2	0-2
Fax adapters		0	0	0	0	0
Cryptographic processors		0	0	0	0	0
System I/O buses		1	1-2	1	1-2	1-2

12.5.2 Model D and E capacities

Feature	Processor	D10	D20	D25	E10	E20	E25
Relative system performance (CPW) ¹		5.3	6.8	9.7	7.6	9.7	11.8
Relative system performance (RAMP-C) ²		1.9	2.4	3.4	2.6	3.5	4.2
Main storage (MB)		8-32	8-40	16-64	8-40	8-72	16-80
Disk storage (MB)		800-9504	800-9504	800-15808	988-19670	988-19670	988-19670
Maximum feature card slots		9	9	9	9	9	9
Communication lines		1-14	1-14	1-14	1-14	1-20	1-26
LAN adapters		0-2	0-2	0-2	0-2	0-2	0-3
Maximum workstation controllers							
Twinaxial		2	2	4	4	4	6
ASCII		4	4	6	9	9	9
LocalTalk		2	2	4	4	4	6
Maximum workstations (one minimum)							
Twinaxial		80	80	160	160	160	240
ASCII		72	72	108	162	162	162
LocalTalk		62	62	124	124	124	186
½-inch cartridge tape		1-2	1-2	1-2	1-2	1-2	1-2
¼-inch reel tape		0-4	0-4	0-4	0-4	0-4	0-4
¼-inch cartridge tape		0-1	0-1	0-1	0-1	0-1	0-1
8 mm cartridge tape		0-4	0-4	0-4	0-4	0-4	0-4
Tape libraries		0-2	0-2	0-2	0-2	0-2	0-2
Optical libraries		0-2	0-2	0-2	0-2	0-2	0-2
Diskette drives (5 ¼-inch or 8-inch)		0-2	0-2	0-2	0-2	0-2	0-2
Fax adapters		0-8	0-8	0-8	0-8	0-8	0-8
Cryptographic processors		0-1	0-1	0-1	0-1	0-1	0-1
System I/O buses		1-2	1-2	1-2	1-2	1-2	1-2

12.5.3 Model F capacities

Feature	Processor	F10	F20	F25
Relative system performance (CPW) ¹		9.6	11.6	13.7
Relative system performance (RAMP-C) ²		3.4	4.2	4.8
Main storage (MB)		8-72	16-80	16-80
Disk storage (GB)		1.03-20.62	1.03-20.62	1.03-20.62
Maximum feature card slots		9	9	9
Communication lines		1-14	1-20	1-26
LAN adapters		0-2	0-4	0-4
Maximum workstation controllers				
Twinaxial		9	9	9
ASCII		9	9	9
LocalTalk		9	9	9
Maximum workstations (one minimum)				
Twinaxial		360	360	360
ASCII		162	162	162
LocalTalk		279	279	279
½-inch cartridge tape		1-2	1-2	1-2
¼-inch reel tape		0-4	0-4	0-4
¼-inch cartridge tape		0-2	0-2	0-2
8 mm cartridge tape		0-4	0-4	0-4
Tape libraries		0-2	0-2	0-2
Optical libraries		0-2	0-4	0-4
Diskette drives (5 ¼-inch or 8-inch)		0-2	0-2	0-2
Fax adapters		0-8	0-8	0-8
Cryptographic processors		0-1	0-1	0-1
System I/O buses		1-2	1-2	1-2

12.6 AS/400 Model B, D, E, F, and 3xx capacities

The 9406 Model B, D, E, and F, and the 3xx systems minimum and maximum capacity tables are provided in the following sections.

12.6.1 Model B capacities

Feature	Processor	B30	B35	B40	B45	B50	B60	B70
Relative system performance (CPW) ¹		3.8	4.6	5.2	6.5	9.3	15.1	20.0
Relative system performance (RAMP-C) ²		1.4	1.6	2.0	2.3	3.2	5.2	7.0
Main storage (MB)		4-36	8-40	8-40	8-40	16-48	32-96	32-192
Disk storage (GB)		0.6-13.7	0.6-13.7	0.6-13.7	0.6-13.7	0.6-27.4	0.6-54.8	0.6-54.8
Minimum feature card slots		5	5	5	5	10	13	13
Maximum feature card slots		14	14	24	24	39	71	71
Main storage feature card slots ¹⁰		2	2	2	2	2	4	4/5
Communication lines		2-16	2-16	2-32	2-32	2-32	2-32	2-48
LAN adapters		0-4	0-4	0-4	0-4	0-4	0-4	0-4
Maximum workstation controllers								
Twinaxial/ASCII		4	4	6	6	10	15	20
¼-inch cartridge tape		0-1	0-1	0-1	0-1	0-1	0-1	0-1
½-inch reel tape								
9347		0-2	0-2	0-2	0-2	0-2	0-2	0-2
9348/2440		0-2	0-2	0-2	0-2	0-4	0-4	0-4
3422/3430		0-1	0-1	0-1	0-1	0-2	0-2	0-2
½-inch cartridge tape								
3480/3490		0-1	0-1	0-1	0-1	0-2	0-2	0-2
8 mm cartridge tape		0-2	0-2	0-2	0-2	0-4	0-4	0-4
Tape libraries (9427 not supported)		0-1	0-1	0-1	0-1	0-2	0-2	0-2
Optical libraries		0	0	0	0	0	0	0
Diskette drives (5 ¼-inch or 8-inch)		0-4	0-4	0-6	0-6	0-10	0-15	0-20
Fax adapters		0	0	0	0	0	0	0
Cryptographic processors		0	0	0	0	0	0	0
System I/O buses		1	1	1	1	2	3	3

12.6.2 Model D capacities

Feature	Processor	D35	D45	D50	D60	D70	D80
Relative system performance (CPW) ¹		7.4	10.8	13.3	23.9	32.3	56.6
Relative system performance (RAMP-C) ²		2.6	3.7	4.8	8.3	11.2	19.8
Number of n-way multiprocessors		1	1	1	1	1	2
Main storage (MB)		8-72	16-80	32-128	64-192	64-256	64-384
Disk storage base (GB)		1.28	1.28	1.28	1.28	1.28	1.28
Maximum internal (GB)		4.1	4.1	4.1	4.1	4.1	4.1
Maximum external (GB)		63.0	63.0	94.3	141.7	141.7	251.8
Minimum feature card slots		11	11	18	18	18	18
Maximum feature card slots		55	55	84	140	140	196
Main storage feature card slots		2	2	5	5	5	5
Communication lines		1-17	1-33	1-33	1-33	1-49	1-64
LAN adapters		0-4	0-4	0-4	0-4	0-4	0-4
Maximum workstation controllers							
Twinaxial/ASCII/LocalTalk		6	10	15	20	30	50
Maximum workstations (one minimum)							
Twinaxial		240	400	600	800	1200	2000
ASCII		108	180	270	360	540	900
LocalTalk		186	310	465	620	930	1550
¼-inch cartridge tape		0-5	0-5	0-9	0-9	0-9	0-9
½-inch reel tape							
9347		0-2	0-2	0-2	0-2	0-2	0-2
2440/9348/3422/3430		0-2	0-2	0-4	0-4	0-4	0-4
½-inch cartridge tape							
3480/3490/3490E/3590/3570		0-2	0-2	0-4	0-4	0-4	0-4
8 mm cartridge tape		0-4	0-4	0-4	0-4	0-4	0-4
Tape libraries		0-2	0-2	0-4	0-4	0-4	0-4
Optical libraries		0-8	0-8	0-14	0-14	0-14	0-14
Diskette drives (5 ¼-inch or 8-inch)		0-2	0-2	0-2	0-2	0-2	0-2
Fax adapters		0-8	0-16	0-16	0-16	0-24	0-32
Cryptographic processors		0-1	0-1	0-1	0-1	0-1	0-1
System I/O buses		2	2	3	3-5	3-5	3-7

12.6.3 Model E capacities

Feature	Processor	E35	E45	E50	E60	E70	E80	E90	E95
Relative system performance (CPW) ¹		9.7	13.8	18.1	28.1	39.2	69.4	96.7	116.6
Relative system performance (RAMP-C) ²		3.4	4.8	6.4	10.2	14.2	25.2	34.4	42.1
Number of n-way multiprocessors		1	1	1	1	1	2	3	4
Main storage (MB)		8-72	16-80	32-128	64-192	64-256	64-512	64-1024	64-1152
Disk storage base (GB)		2.06	2.06	2.06	2.06	2.06	2.06	2.06	2.06
Maximum internal (GB)		4.1	4.1	4.1	4.1	4.1	4.1	4.1	4.1
Maximum external (GB)		63.0	63.0	94.3	141.7	141.7	251.8	251.8	251.8
Minimum feature card slots		11	11	18	18	18	18	18	18
Maximum feature card slots		55	55	84	140	140	196	196	196
Main storage feature card slots		2	2	5	5	5	5	5	5
Communication lines		1-20	1-33	1-33	1-33	1-49	1-64	1-64	1-64
LAN adapters		0-4	0-4	0-4	0-4	0-4	0-6	0-6	0-6
Maximum workstation controllers									
Twinaxial/ASCII/LocalTalk		9	12	18	25	35	60	60	60
Maximum workstations (one minimum)		360	480	720	1000	1400	2400	2400	2400
Twinaxial		162	216	324	450	630	1080	1080	1080
ASCII		279	372	558	775	1085	1860	1860	1860
LocalTalk		0-5	0-5	0-9	0-9	0-9	0-9	0-9	0-9
¼-inch cartridge tape									
½-inch reel tape									
9347		0-2	0-2	0-2	0-2	0-2	0-2	0-2	0-2
2440/9348/3422/3430		0-2	0-2	0-4	0-4	0-4	0-4	0-4	0-4
½-inch cartridge tape									
3480/3490/3490E/3590/3570		0-2	0-2	0-4	0-4	0-4	0-4	0-4	0-4
8 mm cartridge tape		0-4	0-4	0-4	0-4	0-4	0-4	0-4	0-4
Tape libraries		0-2	0-2	0-4	0-4	0-4	0-4	0-4	0-4
Optical libraries		0-8	0-8	0-14	0-14	0-14	0-14	0-14	0-14
Diskette drives (5 ¼-inch or 8-inch)		0-2	0-2	0-2	0-2	0-2	0-2	0-2	0-2
Fax adapters		0-10	0-16	0-16	0-16	0-24	0-32	0-32	0-32
Cryptographic processors		0-1	0-1	0-1	0-1	0-1	0-1	0-1	0-1
System I/O buses		2	2	3	3-5	3-5	3-7	3-7	3-7

12.6.4 Model F capacities

Processor	F35	F45	F50	F60	F70	F80	F90	F95	F97
Relative system performance (CPW) ¹	13.7	17.1	27.8	40.0	57.0	97.1	127.7	148.8	177.4
Relative system performance (RAMP-C) ²	4.8	6.0	10.2	14.7	21.0	36.5	50.5	59.0	71.5
Number of n-way multiprocessors	1	1	1	1	1	2	3	4	4
Main storage (MB)	16-80	16-80	64-192	128-384	128-512	128-768	128-1024	128-1280	128-1536
Disk storage base (GB)	2.06	2.06	2.06	2.06	2.06	2.06	2.06	2.06	2.06
Maximum internal (GB)	4.1	4.1	4.1	4.1	4.1	4.1	4.1	4.1	4.1
Maximum external (GB)	63.0	63.0	110.2	141.7	251.8	251.8	251.8	251.8	251.8
Minimum feature card slots	11	11	18	18	17	17	17	17	17
Maximum feature card slots	55	55	140	140	195	195	195	195	195
Main storage feature card slots	2	2	5	5	5	5	5	5	5
Communication lines	1-20	1-33	1-33	1-33	1-64	1-64	1-64	1-64	1-96
LAN adapters	0-4	0-4	0-4	0-4	0-6	0-6	0-6	0-6	0-8
Maximum workstation controllers									
Twinaxial/ASCII/LocalTalk	12	18	25	35	60	60	60	60	120
Maximum workstations (one minimum)									
Twinaxial	480	720	1000	1400	2400	2400	2400	2400	4800
ASCII	216	324	450	630	1080	1080	1080	1080	2160
LocalTalk	372	558	775	1085	1860	1860	1860	1860	3270
¼-inch cartridge tape									
120 MB	0-1	0-1	0-1	0-1	0-1	0-1	0-1	0-1	0-1
1.2 GB/2.5 GB	0-5	0-5	0-9	0-9	0-9	0-9	0-9	0-9	0-9
½-inch reel tape									
9347	0-2	0-2	0-2	0-2	0-2	0-2	0-2	0-2	0-2
2440/9348/3422/3430	0-2	0-2	0-4	0-4	0-4	0-4	0-4	0-4	0-4
½-inch cartridge tape									
3480/3490/3490E/3590/3570	0-2	0-2	0-4	0-4	0-4	0-4	0-4	0-4	0-4
8 mm cartridge tape	0-4	0-4	0-4	0-4	0-4	0-4	0-4	0-4	0-4
Tape libraries	0-2	0-2	0-4	0-4	0-4	0-4	0-4	0-4	0-4
Optical libraries	0-8	0-8	0-14	0-14	0-14	0-14	0-14	0-14	0-14
Diskette drives (5 ¼-inch or 8-inch)	0-2	0-2	0-2	0-2	0-2	0-2	0-2	0-2	0-2
Fax adapters	0-10	0-16	0-16	0-24	0-32	0-32	0-32	0-32	0-32
Cryptographic processors	0-1	0-1	0-1	0-1	0-1	0-1	0-1	0-1	0-1
System I/O buses	2	2	3-5	3-5	3-7	3-7	3-7	3-7	3-7

12.6.5 Model 300, 310, and 320 capacities

Model	300			310		320		
Processor	#2040	#2041	#2042	#2043	#2044	#2050	#2051	#2052
Feature								
Relative system performance (CPW) ¹	11.6	16.8	21.1	33.8	56.5	67.5	120.3	177.4
Relative system performance (RAMP-C) ³	4.2	6.0	7.5	12.0	20.2	25.7	45.8	71.5
Number of n-way multiprocessors	1	1	1	1	2	1	2	4
Main storage (MB)	8-72	16-80	32-160	64-832	64-832	128-1536	128-1536	128-1536
Disk storage base (GB)		1.03		1.03		1.03		
Maximum internal (GB)		117.44		159.38		259.52		
Maximum external (GB)		94.42		141.63		251.79		
Maximum combined (GB)		117.44		159.38		259.66		
External disk unit IOPS		0-6		0-16		0-28		
Minimum feature card slots		8		3		1		
Maximum feature card slots		45		115		151		
Feature main storage slots		2		3		5		
Communication lines		1-33		1-64		1-96		
LAN adapters ¹³		0-4		0-8		0-8		
Maximum workstation controllers								
Twinaxial/ASCII/LocalTalk		25		60		120		
Maximum workstations (1 minimum)								
Twinaxial		1000		2400		4800		
ASCII		450		1080		2160		
LocalTalk		775		1860		3720		
¼-inch/8 mm cartridge tape (internal)		0-5		0-9		0-9		
½-inch tape (external)								
9348/2440		0-4		0-4		0-4		
34xx/35xx		0-2		0-4		0-4		
8 mm cartridge tape (external)		0-4		0-4		0-4		
Tape libraries		0-2		0-4		0-4		
Optical libraries		0-8		0-14		0-2		
Diskette drives (5 ¼-inch or 8-inch)		0-2		0-2		0-32		
Fax adapters		0-16		0-32		0-1		
Cryptographic processors		0-1		0-1		1-7		
System I/O buses		1-2		1-5				
System expansion								
#5063		0-1						
#5062					0-4		0-6	
#5061					0-4		0-6	
Bus extension								
#5042					0-2		0-3	
#5040/#5060		0-2			0-5		0-6	
Storage expansion								
#5051		0-1			0-1		0	
#5052		0-2			0-5		0-6	

12.7 Notes for all CISC system summary tables

Note 1	Commercial Processing Workload (CPW) is used to measure the performance of all iSeries and AS/400e processors announced from September 1996 onward. The CPW value is measured on maximum configurations. The type and number of disk devices, the number of workstation controllers, the amount of memory, the system model, other factors, and the application running determine what performance is achievable.
Note 2	CPW figures are not available for systems running only SSP.
Note 3	Relative system performance ratios are estimated based on AS/400 environment RAMP-C workload. A measurement of 1.0 is set as the base to represent the performance of a 9404 B10 with 16 MB of main storage and 945 MB of disk storage. The ratios shown are estimated at maximum configurations running at 70% utilization. Relative system performance ratios might not be realized in all environments.
Note 4	The relative system performance for SSP is estimated based on running the System/36 version of RAMP-C with a maximum configured Model 236 equaling 1.0. For OS/400, the relative system performance ratios are estimated based on AS/400 environment RAMP-C workload, with a 9404 Model B10 with 16 MB of main storage and 945 MB of disk equaling 1.0. The ratios shown were estimated at maximum configurations running at 70% utilization. Relative system performance ratios might not be realized in all environments. The SSP relative performance ratings cannot be compared to the OS/400 relative performance ratings.
Note 5	First Figure = Interactive Environment; Second Figure = Client/Server Environment
Note 6	The relative system performance is estimated based on running the System/36 version of RAMP-C in SSP with maximum configured Model 236 equaling 1.0. The SSP relative performance ratings cannot be compared to the OS/400 relative performance ratings. Client results can vary.
Note 7	Some of the hardware on the Model 436 is not supported by SSP and requires OS/400 to support it. Additional hardware can be configured if supported as required.
Note 8	An additional direct access storage device (DASD) can be configured on the 436 with SSP only to support RAID and mirroring.
Note 9	As of February 1997 with V3R7, the maximum disk capacity is 50.3 GB.
Note 10	The number of available main storage features card slots for the Model B70 depends on whether 16 MB or 32 MB main storage cards are installed. When only 16 MB main storage cards are installed, the number of main storage feature card slots is four. When only 32 MB main storage cards are installed, the number of main storage feature card slots is five.
Note 11	The Model 400 and packages, the 40S and packages, the 40E, 41E, 40G, 41G, 40L and 41L packages and Model 436 support three local area network (LAN) adapters if running Firewall for AS/400 (5769-FW1). Package 4HS and 4SS have a base Ethernet or token ring adapter.
Note 12	On LAN and Server Packages, one line must be used to provide system console support.
Note 13	On Models 300 and 320, a one -port or two-port Integrated PC Server (formerly known as File Serving Input Output Processor (FSIOP)) counts as a single LAN. On Model 310, a two-port Integrated PC Server counts as two LANs.
Note 14	When Client Access Console is used, one communication line is reserved for this.

Archived

Summary of AS/400e RISC models

This chapter provides the capacity charts that indicate the minimum and maximum configurations of RISC models of the AS/400e.

For detailed information about RISC features and models, see *IBM eServer AS/400e RISC System Builder Version 3 Release 6 - Version 5 Release 2*, REDP-0342. You can find a summary of CISC models in Chapter 12, "Summary of AS/400 CISC models" on page 389, as well as in *AS/400 CISC System Builder*, REDP-0042.

Note: OS/400 V3R6 through V5R2 support RISC systems.

The following table represents the announcement or general availability and end-of-marketing dates for AS/400e RISC models.

Model and processor	Announce/general availability	Withdrawn from marketing
SB1 #2310, #2311	Announced 19 August 1997	29 December 2000
SB1 #2312, #2313	Announced 1 September 1998	29 December 2000
S10 #2118	19 August 1997	31 May 1999
S10 #2119	19 August 1997	31 May 2000
S20 #2161, #2163, #2165, #2166, #2177, #2178	19 August 1997	31 May 2000
S20 #2170	19 May 1998	31 May 1999
S30 #2257, #2258, #2259, #2260, #2320, #2321, #2322	19 August 1997	31 May 2000
S40 #2256	10 February 1998	31 May 2000
S40 #2261	19 August 1997	31 May 2000
S40 #2207, #2208, #2340, #2341	01 September 1998	31 May 2000

Model and processor	Announce/general availability	Withdrawn from marketing
150 #0181, #0182, #0183, #0184	01 October 1996	12 December 1997
150 #0191, #0192, #0193, #0194	19 August 1997	31 August 1998
150 #0291, #0292, #0293, #0294	10 February 1998	31 December 1999
150 #0391, #0392, #0393, #0394	01 September 1998	31 December 1999
150 #0591, #0592, #0593, #0594	09 February 1999	31 October 2000
40S #2109	20 February 1996	31 August 1998
40S #2110	20 February 1996	31 March 1999
40S #2111, #2112	01 September 1996	31 March 1999
400 #2109 4SS, 4SE, 4SG, 4SL, 4HS, 4HE, 4HG, 4HL	20 February 1996	31 August 1998
400 #2110	20 February 1996	31 March 1999
400 #2111, #2112 4TG and 4TL	1 September 1996	31 March 1999
400 #2130 40E, 40G, 42E, 42G, and 42L	21 June 1995	31 August 1998
400 #2131 41E, 41G, 40L, 41L #2132 41E, #2133 41E	21 June 1995	31 March 1999
Model 400	01 September 1995	30 June 1998
50S #2120	21 June 1995	31 August 1998
50S #2121	21 June 1995	31 March 1999
50S #2122	01 September 1996	31 March 1999
53S #2154	21 June 1995	30 October 1998
53S #2155	21 June 1995	31 March 1999
53S #2156	21 June 1995	01 July 1997
53S #2157	01 September 1996	31 March 1999
Model 5xx	01 September 1995	30 June 1998
600 #2129	19 August 1997	31 May 1999
600 #2134, #2135, #2136, #2179	19 August 1997	31 May 2000
600 #2175	28 October 1997	31 May 2000
620 #2180, #2181, #2182	19 August 1997	31 May 2000
640 #2237, #2238, #2239	19 August 1997	31 May 2000
650 #2240 and #2243	19 August 1997	31 May 2000
650 #2188 and #2189	01 September 1998	31 May 2000

Note: You can find footnotes for each of the table entries in 13.6, “Notes for all RISC system summary tables” on page 424.

13.1 AS/400e Model S10, S20, S30, and S40 capacities

The Model S10, S20, S30, and S40 system minimum and maximum capacities are provided in the following sections.

13.1.1 Model S10 capacities

Processor feature	Model S10	
	#2118	#2119
Relative system performance (CPW) ¹		
Client/server environment	45.4	73.1
Interactive environment	16.2	24.4
Number of n-way multiprocessors	1	1
Main storage (MB)	64-384	128-512
Disk storage base (GB)		4.19
Maximum internal (GB)		
V4R1		85.8
V4R2/V4R3		175.4
System I/O card slots		
SPD		0
PCI		8
Communication lines ⁴		1-10
LAN/ATM adapters		1-3
Maximum workstation controllers		
Twinaxial		1
ASCII		0
Maximum workstations		
Twinaxial (V4R1)		7
Twinaxial (V4R2/V4R3)		28
ASCII		0
¼-inch/8 mm cartridge tape (internal)		0-1
½-inch tape (external)		
Reel 9348		0-1
Reel 2440,9347		0
Cartridge 34xx, 35xx		0-1
8 mm cartridge (external)		0-1
Optical libraries		0-1
Diskettes (5 ¼-inch or 8-inch)		0
Fax adapters		0
Cryptographic processor		0
System I/O buses		1

13.1.2 Model S20 capacities

Processor feature	Model S20						
	#2161	#2163	#2165	#2166	#2170	#2177	#2178
Relative system performance ¹							
Client/server environment	113.8	210.0	464.3	759.0	464.3	759.0	759.0
Interactive environment	31.0	35.8	49.7	56.9	49.7	110.7	221.4
Number of n-way multiprocessors	1	1	2	4	1	4	4
Main storage (MB)	256-2048	256-2048	256-4096	256-4096	256-4096	256-4096	256-4096
Numbers are for all processor features	Base system	SUE #5064 PCI (#9329)¹⁵	SUE #5064 SPD (#9331)¹⁵	Expansion tower	#5065 Expansion Tower	System maximum	
Disk storage base (GB)	4.19	-	-	274.8		4.19	
Maximum internal (GB) (V4R2/V4R3)	263.2 ⁹	263.2	263.2	561.5		944.8	
Maximum external (GB) (V4R2/V4R3)	-	-	Note 8	Note 8		893.3	
Total maximum (GB) (V4R2/V4R3)						944.8	
Total maximum (GB) (V4R4)	263.2 ⁹	263.2	263.2	561.5	386.5	944.8	
Total maximum (GB) (V5R1)	263.2 ⁹	263.2	263.2	561.5	773.0	944.8	
External SPD bus	0	4	4	0		4	
Maximum card slots-SPD	0	0	6	13	0	58	
Maximum card slots-PCI	8	14	0	0	12	22	
Communication lines ⁴	1-10	0-18	0-30	0-78	0-36	96	
LAN/ATM adapters	1-3	0-5	0-6	0-13	3	16	
Maximum workstation controllers ¹⁷					12		
Twinaxial	1	1	1	1		1	
ASCII (V4R1)	0	0	1	1		1	
ASCII (V4R2/V4R3)	0	0	2	2		2	
Maximum workstations ¹⁷							
Twinaxial (V4R1)	7	7	7	7	28	7	
Twinaxial (V4R2/V4R3)	28	28	28	28	1	28	
Twinaxial (V4R4)	0	0	6	6		6	
ASCII (V4R1)	0	0	28	28		28	
ASCII (V4R2/V4R3)							
¼-inch/8 mm cartridge tape (internal)	0-1	0-3	0-3	0-4	0-2	0-17	
½-inch tape (external)							
Reel 9348	0-1	0-2	0-4	0-4		4	
Reel 2440	0	0	0-4	0-4		4	
Reel 9347	0	0	0	0		0	
Cartridge 34xx, 35xx	0-1	0-2	0-4	0-4	0-3	6	
8 mm cartridge (external)	0-1	0-2	0-4	0-4	0-3	4	
Tape libraries	0-1	0-2	0-4		0-3	4	
Optical libraries	0-1	0-2	0-12	0-14	3	14	
Diskettes (5 ¼-inch or 8-inch)	0	0	0-2	0-2		2	
Fax adapters	0	0	0-6	0-13		32	
Cryptographic processor	0	0	0-1	0-1	0-3	1	

13.1.3 Model S30 capacities

Processor feature	Model S30						
	#2257	#2258	#2259	#2260	#2320	#2321	#2322
Relative system performance (CPW) ¹							
Client/server environment	319.0	583.3	998.6	1794.0	998.6	1794.0	1794.0
Interactive environment	51.5	64.0	64.0	64.0	215.1	386.4	579.6
Number of n-way multiprocessors	1	2	4	8	4	8	8
Main storage (MB)							
Minimum	512	512	512	1024	512	1024	1024
Maximum (V4R1/V4R2)	12288	12288	12288	12288	12288	12288	12288
Maximum (V4R3)	16384	16384	16384	24576	16384	24576	24576
Disk storage base (GB)		4.19				4.19	
Maximum internal (GB) (V4R1)		927.7				927.7	
Maximum external (GB) (V4R1)		893.3				893.3	
Maximum combined (GB) (V4R1)		927.7				927.7	
Max internal (GB) (V4R2/V4R3)		1340.0				1340.0	
Maximum external (GB) (V4R2/V4R3)		1305.6				1305.6	
Maximum combined (GB) (V4R2/V4R3)		1340.0				1340.0	
Disk unit IOPs		1-37				1-37	
Minimum feature card slots		3				3	
Maximum feature card slots		235				235	
Communication lines		1-200				1-200	
LAN/ATM adapters ⁷		1-32				1-32	
Maximum workstation controllers							
Twinaxial		1				175	
ASCII (V4R1)		1				175	
ASCII (V4R2/V4R3)		2				175	
Maximum workstations							
Twinaxial (V4R1)		7				7000	
Twinaxial (V4R2/V4R3)		28				7000	
ASCII (V4R1)		6				3150	
ASCII (V4R2/V4R3)		28				3150	
¼-inch/8 mm cartridge tape (internal)		0-17				0-17	
½-inch tape (external)							
Reel 2440, 9348		0-4				0-4	
34xx, 35xx		0-8				0-8	
8 mm cartridge tape (external)		0-4				0-4	
Optical libraries		0-22				0-22	
Diskettes (5 ¼-inch or 8-inch)		0-2				0-2	
Fax adapters		0-32				0-32	
Cryptographic processor		0-1				0-1	
System I/O buses		1-19				1-19	
System expansion		0-18				0-18	
(#5072, #5073, #5082, #5083)							
Storage expansion (#5055/#5057)		0-1				0-1	
Storage expansion (#5052/#5058)		0-18				0-18	

RISC Models

13.1.4 Model S40 capacities

Processor feature	Model S40					
	#2256	#2261	#2207	#2208	#2340	#2341
Relative system performance (CPW) ¹						
Client/server environment	1794	2340	3660	4550	3660	4450
Interactive environment	64	64	120	120	1050	2050
Number of n-way multiprocessors	8	12	8	12	8	12
Main storage (MB)						
Minimum	1024	1024	1024	1024	1024	1024
Maximum (V4R1/V4R2)	20480	20480	-	-	-	-
Maximum (V4R3)	32768	32768	40960	40960	40960	40960
Disk storage base (GB)						
Minimum			4.19			4.19
V4R1						
Maximum internal			996.4			-
Maximum external			893.3			-
Maximum combined			996.4			-
V4R2						
Maximum internal			1546.1			-
Maximum external			1511.8			-
Maximum combined			1546.8			-
V4R3						
Maximum internal			2095.9			2095.9
Maximum external			2061.3			2061.3
Maximum combined			2095.9			2095.9
Disk unit IOPs			1-37			1-37
Minimum feature card slots			3			3
Maximum feature card slots			237			237
Communications lines						
V4R1/V4R2			1-250			-
V4R3			1-300			1-300
LAN/ATM adapters ⁷						
V4R1/V4R2			1-48			-
V4R3			1-72			1-72
Workstation controllers			1-3			1-175
Twinaxial			0-1			0-175
ASCII (V4R1)			0-1			-
ASCII (V4R2/V4R3)			0-2			0-175
Maximum workstations						
Twinaxial (V4R1)			7			-
Twinaxial (V4R2/V4R3)			28			7000
ASCII (V4R1)			6			-
ASCII (V4R2/V4R3)			28			3150
¼-inch/8 mm cartridge tape			0-17			0-17
½-inch tape (internal)						
½-inch Tape (external)						
Reel-to-reel (2440, 9348)			0-4			0-4
Cartridge (34xx, 35xx)			0-8			0-8
8 mm cartridge tape (external)			0-4			0-4
Optical libraries			0-22			0-22
Diskettes (5 ¼-inch or 8-inch)			0-2			0-2
Fax adapters			0-32			0-32
Cryptographic processor			0-1			0-1
System I/O buses			1-19			1-19
System expansion			0-18			0-18
(#5072, #5073, #5082, #5083)						
Storage expansion (#5057)			0-1			0-1
Storage expansion (#5052/#5058)			0-18			0-18

13.2 AS/400e Model 150 capacities

The Model 9406 150 system minimum and maximum capacities are provided in the following tables.

Package	Twinaxial Entry #0181	Twinaxial Growth #0182	Server Entry #0183	Server Growth #0184	Twinaxial Entry #0191	Twinaxial Growth #0192	Server Entry #0193	Server Growth #0194
Minimum software release	V3R7	V3R7	V3R7	V3R7	V4R1	V4R1	V4R1	V4R1
Relative system performance (CPW-V3R7)								
Constrained ^{1,2}	10.9/10.9	10.9/10.9	10.9/10.9	10.9/10.9	N/A	N/A	N/A	N/A
Unconstrained ^{1,2}	13.8/27.0	20.6/33.3	13.8/27.0	20.6/33.3	N/A	N/A	N/A	N/A
Relative system performance (CPW-V4R1, V4R2/V4R3)								
Constrained ^{1,2}	13.8/20.2	20.2/20.2	13.8/20.2	20.2/20.2	13.8/20.2	20.2/20.2	13.8/20.2	20.2/20.2
Unconstrained ^{1,2}	13.8/27.0	20.6/35.0	13.8/27.0	20.6/35.0	13.8/27.0	20.6/35.0	13.8/27.0	20.6/35.0
Main storage (V3R7) (MB)	32-96	64-96	32-96	64-96	N/A	N/A	N/A	N/A
Main storage (V4R1/R2/R3) (MB)	64-192	64-192	64-192	64-192	64-192	128-192	64-192	128-192
Disk storage (V3R7/V4R1) (GB)	4.19-16.77	4.19-16.77	4.19-16.77	4.19-16.77	4.19-16.77	4.19-16.77	4.19-16.77	4.19-16.77
Disk storage (V4R2/V4R3) (GB)	4.19-29.9	4.19-29.9	4.19-29.9	4.19-29.9	4.19-29.9	4.19-29.9	4.19-29.9	4.19-29.9
Maximum feature card slots ¹³	5	5	5	5	5	5	5	5
Communication lines	1-5	1-5	1-5	1-5	1-5	1-5	1-5 ²¹	1-5 ²¹
LAN IOAs	0-2	0-2	1-2	1-2	0-2	0-2	1-2	1-2
Integrated PC Server LANs	2	2	2	2	2	2	2	2
MFIOP LANs	1	1	1	1	1	1	1	1
Workstation controllers								
Twinaxial	1	1	0-1	0-1	1	1	0-1	0-1
ASCII	0	0	0	0	0	0	0	0
Workstations								
Twinaxial (V3R7, V4R1)	1-7	1-14	0-7	0-14	1-7	1-14	0-7	0-14
Twinaxial (V4R2, V4R3)	1-7	1-28	0-7	0-28	1-7	1-28	0-7	0-28
ASCII	0	0	0	0	0	0	0	0
¼-inch cartridge tape (2.5 GB)	1	1	1	1	1	1	1	1
½-inch reel tape	0	0	0	0	0	0	0	0
½-inch cartridge tape	0	0	0	0	0	0	0	0
8 mm cartridge tape	0	0	0	0	0	0	0	0
Tape libraries	0	0	0	0	0	0	0	0
Optical libraries	0	0	0	0	0	0	0	0
Diskettes	0	0	0	0	0	0	0	0
Fax adapters	0	0	0	0	0	0	0	0
Cryptographic processors	0	0	0	0	0	0	0	0
System I/O buses	0	0	0	0	0	0	0	0

Package	Twinaxial Entry #0291/#0391 #0591	Twinaxial Growth #0292/#0392 #0592	Server Entry #0293/#0393 #0593	Server Growth #0294/#0394 #0594
Minimum OS/400 release	V4R2/V4R3 V4R4	V4R2/V4R3 V4R4	V4R2/V4R3 V4R4	V4R2/V4R3 V4R4
Relative system performance (CPW) ^{1, 2}				
Constrained	13.8/20.2	20.2/20.2	13.8/20.2	20.2/20.2
Unconstrained	13.8/27.0	20.6/35.0	13.8/27.0	20.6/35.0
Main storage (MB)	64-192	128-192	64-192	128-192
Disk storage (GB)	4.19-29.9	4.19-29.9	4.19-29.9	4.19-29.9
Maximum feature card slots ^{14, 20}	5	5	5	5
Communication lines ²⁰	1-5	1-5	1-5 ²⁰	1-5 ²⁰
LAN IOAs	0-2	0-2	1-2	1-2
#2790 PCI Integrated Netfinity Server LANs	0-2	0-2	0-2	1-2
MFIO LANs	1	1	1	1
Workstation controllers				
Twinaxial	1	1	0-1	0-1
ASCII	0	0	0	0
LocalTalk	0	0	0	0
Workstations				
Twinaxial	1-7	1-28	0-7	0-28
ASCII	0	0	0	0
LocalTalk	0	0	0	0
¼-inch cartridge tape (4.0 GB)	1	1	1	1
½-inch reel tape	0	0	0	0
½-inch cartridge tape	0	0	0	0
8 mm cartridge tape	0	0	0	0
Tape libraries	0	0	0	0
Optical libraries	0	0	0	0
Diskettes	0	0	0	0
Fax adapters	0	0	0	0
Cryptographic processors	0	0	0	0
System I/O buses	0	0	0	0

13.3 AS/400e Model 4HS, 4HE, 4HG, 4HL, 42E, 42G, and 42L packages and Model 4SS, 4SE, 4SG, 4TG, 4SL, 4TL, 40E, 41E, 40G, 41G, 40L, 41L, 400, and 40S capacities

The 9406 Model 4HS, 4HE, 4HG, 4HL, 42E, 42G, and 42L packages and the 9406 Model 4SS, 4SE, 4SG, 4TG, 4SL, 4TL, 40E, 41E, 40G, 41G, 40L, 41L, 400, and 40S systems minimum and maximum capacities are provided in the following sections.

13.3.1 Model 4HS, 4HE, 4HG, and 4HL package capacities

Package name	Small Server 4HS	Entry Server 4HE	Growth Server 4HG	Large Server 4HL
Relative system performance (CPW-V3R6) ¹				
Client/server environment	24.5-77.3	24.5-52.9	24.5-52.9	24.5-52.9
Interactive environment	8.4-26.9	8.4-18.3	8.4-18.3	8.4-18.3
Relative system performance (CPW-V3R7) ¹				
Client/server environment	27.0-87.3	27.0-59.8	27.0-59.8	27.0-59.8
Interactive environment	9.4-30.7	9.4-20.6	9.4-20.6	9.4-20.6
Main storage (MB) ²²	32-224/64-512	32-224/64-512	64-224/128-512	96-224/128-512
Disk storage (GB) ¹¹	3.93-23.6	3.93-23.6	7.84-23.6	11.0-23.6
Standard tape cartridge	¼-inch	¼-inch	¼-inch	8 mm
Twinaxial devices (maximum)	7	7	7	7
LAN adapters ¹⁸	1-2	1-2	1-2	1-2
Communication lines	1-20	2-20	2-20	2-20

13.3.2 Model 42E, 42G, and 42L package capacities

Package name	Entry 42E	Growth 42G	Large 42L
Relative system performance (CPW-V3R6) ¹	12.3-30.6	12.3-30.6	12.3-30.6
Relative system performance (CPW-V3R7) ¹	13.8-33.3	13.8-33.3	13.8-33.3
Main storage (MB) ²³	64-160/64-224	96-160/96-224	160/160-224
Disk storage (GB) ¹¹	3.93-23.6	7.84-23.6	11.80-23.6
Standard tape cartridge	¼-inch	¼-inch	8 mm
Twinaxial devices	40-280	40-280	80-280
LAN adapters ¹⁸	0-2	0-2	0-2
Communications	1-20	2-20	2-20

13.3.3 Model 4SS, 4SE, 4SG, 4TG, 4SL, and 4TL capacities

Package name	Small Server 4SS	Entry Server 4SE	Growth Server 4SG	Growth Server 4TG	Large Server 4SL	Large Server 4TL
Relative system performance (CPW-V3R6) ¹						
Client/server environment	24.5-52.9	24.5-52.9	24.5-52.9	77.3	24.5-52.9	77.3
Interactive environment	8.4-18.3	8.4-18.3	8.4-18.3	26.9	8.4-18.3	26.9
Relative system performance (CPW-V3R7) ¹						
Client/server environment	27.0-59.8	27.0-59.8	27.0-59.8	87.3	27.0-59.8	87.3
Interactive environment	9.4-20.6	9.4-20.6	9.4-20.6	30.7	9.4-20.6	30.7
Main storage (MB) ²²	32-224/ 64-512	32-224/ 64-512	32-224/ 64-512	128-512	96-224/ 128-512	128-512
Disk storage (GB) ¹¹	3.93-23.6	3.93-23.6	7.86-23.6	7.86-23.6	11.0-23.6	11.80-23.6
Standard tape cartridge	¼-inch	¼-inch	¼-inch	¼-inch	8 mm	8 mm
Twinaxial devices	7	7	7	7	7	7
LAN adapters ¹⁸	1-2	1-2	1-2	1-2	1-2	1-2
Communication lines	2-20	2-20	2-20	2-20	2-20	2-20
Software Charge Group	P05	P05	P05	P10	P05	P10

13.3.4 Model 40E, 41E, 40G, 41G, 40L, and 41L capacities

Package name	Entry 40E	Entry 41E	Growth 40G	Growth 41G	Large 40L	Large 41L
Relative system performance (CPW-V3R6) ¹	12.3	18.3-30.6	12.3	12.3	12.3	12.3
Relative system performance (CPW-V3R7) ¹	13.8	20.6-33.3	13.8	20.6-33.3	13.8	20.6-33.3
Main storage (MB)	64-160	64-224	96-180	96-224	160	160-224
Disk storage (GB) ¹¹	3.93-23.6	3.93-23.6	7.86-23.6	7.86-23.6	11.80-23.6	11.80-23.6
Standard tape cartridge	¼-inch	¼-inch	¼-inch	¼-inch	8 mm	8 mm
Twinaxial devices	40-280	40-280	40-280	40-280	80-280	80-280
LAN adapters ¹⁸	0-2	0-2	0-2	0-2	0-2	0-2
Communication lines	1-20	1-20	2-20	2-20	2-20	2-20
Software Group	P05	P10	P05	P05	P05	P10

13.3.5 Model 400 capacities

Processor feature	400			
	#2130	#2131	#2132	#2133
Relative system performance (CPW-CISC or V3R6 RISC) ¹	12.3	18.3	24.5	30.6
Relative system performance (CPW - V3R7 RISC) ¹	13.8	20.6	27.0	33.3
Relative system performance (CPW - V4R1 RISC) ¹	13.8	20.6	27.0	35.0
Relative system performance (RAMP-C) ³	4.1	6.1	8.7	10.9
Main storage (MB)	32-160	32-224	32-224	32-224
Disk storage (GB) (V3R1/V3R6) (V3R2/V3R7, V4R1/V4R2/V4R3)		1.96-23.6 1.96-50.3		
Maximum feature card slots		6		
Communication lines		1-20		
LAN adapters ¹⁸		0-2		
ATM adapters		0-1		
Maximum workstation controllers		7		
Twinaxial		7		
ASCII		7		
LocalTalk		7		
Maximum workstations				
Twinaxial		280		
ASCII		126		
LocalTalk		217		
¼-inch/8 mm cartridge tape (internal)		0-4		
½-inch tape (external)				
9348		0-4		
34xx/35xx		0-2		
8 mm cartridge tape (external)		0-4		
Tape libraries		0-2		
Optical libraries		0-4		
Diskettes (5 ¼-inch or 8-inch)		0-2		
Fax adapters		0-6		
Cryptographic processors		0-1		
System I/O buses		1		

13.3.6 Model 40S capacities

Processor	9402 40S	9402 40S	9402 40S	9402 40S
Feature	#2109	#2110	#2111	#2112
Relative system performance (CPW-V3R6) ¹				
Client/server environment	24.5	30.6	52.9	77.3
Interactive environment	8.4	12.3	18.3	26.9
Relative system performance (CPW-V3R7) ¹				
Client/server environment	27.0	33.3	59.8	87.3
Interactive environment	9.4	13.8	20.6	30.7
Relative system performance (CPW-V4) ¹				
Client/server environment	27.0	35.0	63.0	91.0
Interactive environment	9.4	14.5	21.6	32.2
Relative system performance (RAMP-C) ³				
Client/server environment	8.3	10.6	† ¹⁰	† ¹⁰
Interactive environment	2.6	3.8	† ¹⁰	† ¹⁰
Number of n-way multiprocessors	1	1	1	1
Main storage (MB) ²²	32-224		64-512	
Disk storage (GB)				
V3R6			1.96-23.6	
V3R7			1.96-50.3	
V4			1.96-50.3	
Maximum feature card slots			5	
Communication lines			1-20	
LAN ports ¹⁸			1-2	
ATM ports			0-1	
Maximum workstation controllers				
Twinaxial			1	
ASCII			1	
LocalTalk			1	
Maximum workstations (1 minimum)				
Twinaxial			7	
ASCII			6	
LocalTalk devices			31	
¼-inch cartridge tape/8 mm			0-4	
Cartridge tape (internal)				
½-inch tape 9348/2440 (external)			0-4	
2440 is not supported on Model 40S				
34xx/35xx			0-2	
8 mm cartridge tape (external)			0-4	
Tape libraries			0-2	
Optical libraries			0-4	
Diskettes (5 ¼-inch or 8-inch)			0-2	
Fax adapters			0-5	
Cryptographic processors			0-1	
System I/O buses			1	

13.4 AS/400e Model 50S, 53S, 500, 510, and 530 capacities

The 9406 Model 50S, 53S, 500, 510, and 530 systems minimum and maximum capacities are provided in the following sections.

13.4.1 Model 50S, and 53S capacities

Processor	50S	50S	50S	53S	53S	53S	53S
Feature	#2120	#2121	#2122	#2154	#2155	#2156	#2157
Relative system performance (CPW-V3R6) ¹							
Client/server environment	66.7	85.0	106.8	132.5	198.7	299.0	349.8
Interactive environment	18.7	26.9	26.9	26.9	26.9	26.9	26.9
Relative system performance (CPW-V3R7) ¹							
Client/server environment	77.7	104.2	130.7	162.7	278.8	459.3	509.9
Interactive environment	21.4	30.7	30.7	30.7	30.7	30.7	30.7
Relative system performance (CPW-V4) ¹							
Client/server environment	81.6	111.5	138.0	188.2	319.0	598.0	650.0
Interactive environment	22.5	32.8	32.8	32.8	32.8	32.8	32.8
Relative system performance (RAMP-C) ³							
Client/server environment	19.7	26.6	† ¹⁰	43.4	66.6	101.4	† ¹⁰
Interactive environment	5.7	8.3	† ¹⁰	8.3	8.3	8.3	† ¹⁰
Number of n-way multiprocessors	1	1	1	1	2	4	4
Main storage (MB)	64-1024			256-4096			512-4096
Disk storage (GB)							
V3R6	1.96-318.7			1.96-520.0			
V3R7	1.96-318.7			1.96-520.0			
V4	4.19-652.8			4.19-996.4			
Maximum feature card slots	82			237			
Communication lines	1-96			1-200			
LAN ports ¹⁸	1-16			1-32			
ATM ports	0-8			0-16			
Maximum workstation controllers							
Twinaxial	1			1			
ASCII	1			1			
LocalTalk	2			4			
Maximum workstations (1 minimum)							
Twinaxial	7			7			
ASCII	6			6			
LocalTalk devices	62			124			
¼-inch cartridge tape/8 mm	17			0-17			
Cartridge tape (internal)							
½-inch tape 9348/2440 (external)	0-4			0-4			
2440 is not supported on Model 40S							
34xx/35xx	0-4			0-4			
8 mm cartridge tape (external)	0-4			0-4			
Tape libraries	0-2			0-2			
Optical libraries	0-14			0-22			
Diskettes (5 ¼-inch or 8-inch)	0-2			0-2			
Fax adapters	0-32			0-32			
Cryptographic processors	0-1			0-1			
System I/O buses	1-7			0-19			

13.4.2 Model 500, 510, and 530 capacities

Model	500			510		530				
	#2140	#2141	#2142	#2143	#2144	#2150	#2151	#2152	#2153	#2162
Relative system performance (CPW-V3R6) ¹	18.7	26.9	38.3	66.7	85.0	107.1	132.5	198.7	299.0	349.8
Relative system performance (CPW-V3R7) ¹	21.4	30.7	43.9	77.7	104.2	131.1	162.7	278.8	459.3	509.9
Relative system performance (CPW-V4) ¹	21.4	30.7	43.9	81.6	111.5	148.0	188.2	319.0	598.0	650.0
Relative system performance (RAMP-C) ³	6.4	9.3	12.6	21.6	28.5	37.4	48.9	74.0	119.2	Note 1
Number of n-way multiprocessors	1	1	1	1	1	1	1	2	4	4
Main storage (MB)	64-76 8	64-76 8	64-102 4	256-10 24	256-10 24	512-40 96	512-40 96	512-40 96	512-40 96	512-40 96
Disk storage base (GB)										
V3R6/R7		1.96			1.96			1.96		
V4		4.19			4.19			4.19		
Maximum internal-GB										
V3R6/R7		150.99			318.76			520.09		
V4		652.80			652.80			996.40		
Maximum external-GB										
V3R6/R7		134.21			301.98			503.31		
V4		618.40			618.40			962.00		
Maximum combined-GB										
V3R6/R7		150.99			318.76			520.09		
V4		652.80			652.80			996.40		
Disk unit IOPS										
Internal		0-13			0-13					
External		0-16			0-28					
Minimum feature card slots		6			6			4		
Maximum feature card slots		83			83			238		
Communication lines		1-33			1-96			1-200		
LAN ports		0-16			0-16			0-32		
ATM ports		0-8			0-8			0-16		
Maximum workstation controllers										
Twinaxial/ASCII/LocalTalk		35			60			175		
Maximum workstations - Min. of 1										
Twinaxial		1400			2400			7000		
ASCII		630			1080			3150		
LocalTalk		1085			1860			5425		
¼-inch/8 mm cartridge tape (internal)		0-9			0-17			0-17		
½-inch tape (external)										
9348/2440		0-4			0-4			0-4		
34xx/35xx		0-4			0-4			0-4		
8 mm cartridge tape (external)		0-4			0-4			0-4		
Tape libraries		0-2			0-2			0-2		
Optical libraries		0-14			0-14			0-22		
Diskettes (5¼-inch or 8-inch)		0-2			0-2			0-2		
Fax adapters		0-16			0-32			0-32		
Cryptographic processors		0-1			0-1			0-1		
System I/O buses		1-7			1-7			1-19		
System expansion										
#507x/#508x		0-6			0-6			0-18		
Bus extension										
#5044		0-3			0-3			0-9		
Storage expansion										
#5051		0-1			0-1					
#5052/#5058		0-7			0-7			0-18		
#8052/#9051								1		

13.5 AS/400e Model 600, 620, 640, and 650 capacities

The 9406 Model 600, 620, 640, and 650 systems minimum and maximum capacities are provided in the following sections.

13.5.1 Model 600 capacities

Processor feature	Model 600			
	#2129	#2134	#2135	#2136
Relative system performance (CPW) ¹	22.7	32.5	45.4	73.1
Number of n-way multiprocessors	1	1	1	1
Main storage (MB)	64-384	64-384	64-384	128-512
Disk storage base (GB)				
Maximum internal (GB)			4.19	
V4R1			85.8	
V4R2 and later			175.4	
System I/O card slots				
SPD			0	
PCI			8	
Communication lines ⁵			1-18	
LAN/ATM adapters			0-3	
Maximum workstation controllers				
Twinaxial			5	
ASCII			0	
Maximum workstations				
Twinaxial			188	
ASCII			0	
¼-inch/8 mm cartridge tape (internal)			0-1	
½-inch tape (external)				
Reel 9348			0-1	
Reel 2440, 9347			0	
Cartridge 34xx, 35xx			0-1	
8 mm cartridge (external)			0-1	
Optical libraries			0-1	
Diskettes (5 ¼-inch or 8-inch)			0	
Fax adapters			0	
Cryptographic processor			1	
System I/O buses			1	

13.5.2 Model 620 capacities

Processor feature	Model 620					
	#2175	#2179	#2180		#2181	#2182
Relative system performance (CPW) ¹	50.0	85.6	113.8		210.0	464.3
Number of n-way multiprocessors	1	1	1		1	2
Main storage (MB)	64-1856 ¹⁶	256-2048	256-2048		256-2048	256-4096
Numbers are for all processor features	Base system	SUE #9364 PCI (#9329) (#9330)¹²	SUE #9364 SPD (#9331)¹²	#5065 Strg/PCI Expansion Tower	Expansion tower	System maximum
Disk storage base (GB)	4.19	-	-		-	4.19
V4R1						
Maximum internal (GB)	128.8 ⁹	128.8	128.8 ⁸		274.8 ⁸	704.3
Maximum external (GB)	-	-	-		-	652.8
Total maximum (GB)						704.3
V4R2/V4R3						
Maximum internal (GB)	263.2 ⁹	263.2	263.2 ⁸		561.5 ⁸	944.8
Maximum external (GB)	-	-	-		-	893.3
Total maximum (GB)						944.8
V4R4						
Maximum internal (GB)	263.2 ⁹	263.2	263.2 ⁸	386.5	561.5 ⁸	944.8
Maximum external (GB)	-	-	-		-	893.3
Total maximum (GB)						944.8
V5R1						
Maximum internal (GB)	263.2 ⁹	263.2	263.2 ⁸	773.0	561.5 ⁸	944.8
Maximum external (GB)	-	-	-		-	893.3
Total maximum (GB)						944.8
External SPD bus	0	4	4		0	4
Maximum card slots - SPD	0	0	6	0	13	58
Maximum card slots - PCI	8	14	0	12	0	22
Communication lines ⁵	1-18	0-40	0-36	0-42	0-78	96
LAN/ATM adapters	0-3	0-5	0-6	0-6	0-13	16
Maximum workstation controllers						
Twinaxial	5	9	18	12	39	60
ASCII	0	0	6	0	13	58
Maximum workstations						
Twinaxial	188	360	720	240	1560	2388
ASCII	0	0	108	0	234	1044
¼-inch/8 mm cartridge tape (internal)	0-1	0-3	0-3	0-2	0-4	17
½-inch tape (external)						
Reel 9348	0-1	0-2	0-4	0-3	0-4	4
Reel 2440	0	0	0-4	0	0-4	4
Reel 9347	0	0	0-2	0	0-2	2
Cartridge 34xx, 35xx	0-1	0-2	0-4	0-3	0-4	6
8 mm cartridge (external)	0-1	0-2	0-4	3	0-4	4
Optical libraries	0-1	0-2	0-12	3	0-14	14
Diskettes (5 ¼-inch or 8-inch)	0	0	0-2	0	0-2	2
Fax adapters	0	0	0-6	0	0-13	32
Cryptographic processor	0	0	0-1	3	0-1	3

13.5.3 Model 640 and 650 capacities

Processor feature	Model 640			Model 650			
	#2237	#2238	#2239	#2240	#2243	#2188	#2189
Relative system performance (CPW) ¹	319.0	583.3	998.6	1794.0	2340.0	3660.0	4550.0
Number of n-way multiprocessors	1	2	4	8	12	8	12
Main storage (MB)							
V4R2	512-12288	512-12288	512-12288	1024-20480	1024-20480	-	-
V4R3	512-16384	512-16384	512-16384	1024-32758	1024-32758	1024-40960	1024-40960
Disk storage base (GB)	4.19			4.19			
V4R1							
Maximum internal (GB)	927.7			996.4			
Maximum external (GB)	893.3			962.0			
Maximum combined (GB)	927.7			996.4			
V4R2							
Maximum internal (GB)	1340.0			1546.1			
Maximum external (GB)	1305.6			1511.8			
Maximum combined (GB)	1340.0			1546.1			
V4R3/V4R4							
Maximum internal (GB)	1340.0			2095.9			
Maximum external (GB)	1305.6			2061.3			
Maximum combined (GB)	1340.0			2095.9			
Disk unit IOPs	1-37			1-37			
Minimum feature card slots	3			3			
Maximum feature card slots-SPD	235			237			
Maximum feature card slots-PCI	216			216			
Communications lines (V4R1/V4R2)	1-200			1-250			
Communications lines (V4R3/V4R4)	1-200			1-300			
LAN/ATM adapters ⁷	0-32			0-48			
V4R1/V4R2/V4R3	0-32			0-72			
Maximum workstation controllers							
Twinaxial / ASCII	175			175			
Maximum workstations							
Twinaxial	7000			7000			
ASCII	3150			3150			
¼-inch/8 mm cartridge tape (internal)	0-17			0-17			
½-inch tape (external)							
Reel 2440, 9348	0-4			0-4			
34xx, 35xx	0-8			0-8			
9347	0-2			0-2			
8 mm cartridge tape (external)	0-4			0-4			
Optical libraries	0-22			0-22			
Diskettes (5 ¼-inch or 8-inch)	0-2			0-2			
Fax adapters	0-32			0-32			
Cryptographic processor	0-3			0-3			
System I/O buses	1-19			1-19			
System expansion							
#5065, #5072, #5073, #5082, #5083	0-18			0-18			
Bus expansion (#5044)	0-9			0-9			
Storage expansion							
#5055/#5057	0-1			0-1			
#5052/#5058	0-18			0-18			

13.6 Notes for all RISC system summary tables

Note 1	Commercial Processing Workload (CPW) is used to measure the performance of all iSeries and AS/400e processors announced from September 1996 onward. The CPW value is measured on maximum configurations. The type and number of disk devices, the number of workstation controllers, the amount of memory, the system model, other factors, and the application running determine what performance is achievable.
Note 2	The constrained figures are for the 9401 Model 150 with its maximum configuration. The unconstrained figures show what the performance would be if the processor was not limited by the maximum main storage and direct access storage device (DASD) of the Model 150. In each case, the figure is for interactive workload, and the second is for client/server.
Note 3	Relative system performance ratios are estimated based on AS/400 environment RAMP-C workload. A measurement of 1.0 is set as the base to represent the performance of a 9404 B10 with 16 MB of main storage and 945 MB of disk storage. The ratios shown are estimated at maximum configurations running at 70% utilization. Relative system performance ratios might not be realized in all environments.
Note 4	One line is used for Operations Console or Client Access if selected. The maximum is nine if Twinaxial Console is selected.
Note 5	Seventeen lines in the base system if Client Access Operations Console is chosen.
Note 7	Can include up to 16 Integrated PC Servers
Note 8	External DASD can be attached via an SPD card in the expansion unit.
Note 9	Maximum is 85.8 GB (V4R1) or 175.4 GB (V4R2/V4R3/V4R4) on the #2161 processor
Note 10	Information not available.
Note 11	As of February 1997 with V3R7, the maximum disk capacity is 50.3 GB.
Note 12	The #9364 must be configured with #9329/#9330 (PCI) or #9331 (SPD). Therefore, these columns are mutually exclusive.
Note 13	Two of these slots are reserved for the Integrated PC Server. Three are driven by the MFIOP.
Note 14	Three are driven by the MFIOP. Two of these slots are reserved for the Integrated PC Server.
Note 15	The #5064 must be configured with #9329 (PCI) or #9331 (SPD). Therefore, these columns are mutually exclusive.
Note 16	The #0004 specify code indicates that the Model 620 #2175 processor shipped with base memory of 256 MB. These systems have a maximum memory of 2048 MB.
Note 17	The S20 processors #2170, #2177, and #2178 support a maximum of 60 twinaxial and 58 ASCII Workstations Controllers and 2392 twinaxial and 1044 ASCII Workstations
Note 18	The Model 400 and packages, the 40S and packages, the 40E, 41E, 40G, 41G, 40L and 41L packages and Model 436 support three LAN adapters if running Firewall for AS/400 (5769-FW1). Package 4HS and 4SS have a base Ethernet or token-ring adapter.
Note 20	Six lines are supported, but one is dedicated to Client Access Console (#029x Packages) or Operations Console (#039x and 059x packages).
Note 21	Six lines are supported, but one is dedicated to Client Access Console.
Note 22	The #2109 and #2110 processor support 32 to 224 MB main storage. The #2111 and #2112 processor support 64 to 512 MB main storage.
Note 23	The #2130 processor supports 160 MB main storage. The #2131, #2132, and #2133 processors support a maximum of 224 MB main storage.

Related publications

The publications listed in this section are considered particularly suitable for a more detailed discussion of the topics covered in this redbook.

IBM Redbooks

For information about ordering the following publications, see “How to get IBM Redbooks” on page 427. Note that some of the documents referenced here might be available in softcopy only.

- ▶ *IBM eServer i5 and iSeries System Handbook i5/OS Version 5 Release 3 October 2005 - Draft*, GA19-5486
- ▶ *IBM eServer iSeries Migration: System Migration and Upgrades at V5R1 and V5R2*, SG24-6055
- ▶ *iSeries in Storage Area Networks A Guide to Implementing FC Disk and Tape with iSeries*, SG24-6220
- ▶ *IBM TotalStorage Tape Selection and Differentiation Guide*, SG24-6946
- ▶ *IBM eServer iSeries Migration: A Guide to Upgrades and Migrations to POWER Technology*, SG24-7200
- ▶ *IBM eServer iSeries Pocket Handbook: Version 5 Release 2 January 2003*, SG24-9406
- ▶ *AS/400 CISC System Builder*, REDP-0042
- ▶ *IBM eServer AS/400e RISC System Builder Version 3 Release 6 - Version 5 Release 2*, REDP-0342
- ▶ *IBM eServer iSeries and AS/400e System Builder: IBM OS/400 Version 4 Release 3 - Version 5 Release 2*, REDP-0542
- ▶ *IBM TotalStorage Enterprise Storage Server Model 800*, SG24-6424
- ▶ *PCI Card Placement Rules for the IBM eServer iSeries Server OS/400 Version 5 Release 2: September 2003*, REDP-3638
- ▶ *PCI and PCI-X Placement Rules for IBM System i5, eServer i5, and iSeries servers with i5/OS V5R4 and V5R3*, REDP-4011
- ▶ *High-speed Link Loop Architecture for the IBM eServer iSeries Server: OS/400 Version 5 Release 2*, REDP-3652

The latest update to this IBM Redbook is always available in softcopy on the World Wide Web. As System i5, eServer i5, iSeries, and i5/OS announcements occur, the contents of this redbook are refreshed to help keep you informed about changes that occur between IBM printed hardcopy editions of this redbook. eServer

When the Redbook is in final form, the edition can be ordered in hardcopy from a print-on-demand vendor. Simply click the **Order hardcopy** or **Buy now** button at the IBM Redbooks Web site. On the same Web site, you can view, search, or download the latest PDF or HTML formats. When you reach the site, enter a search parameter of iSeries Builder or SG24-2155. The IBM Redbooks Web site is located at:

<http://www.redbooks.ibm.com>

You can access the latest PDF file of the Builder directly at:

<http://www.redbooks.ibm.com/pubs/pdfs/redbooks/sg242155.pdf>

Other publications

The following publications are also relevant as further information sources:

- ▶ *AS/400 Physical Planning Reference*, SA41-5109
- ▶ *AS/400 RoadMap for Changing to PowerPC Technology*, SA41-5150
- ▶ *System Upgrade RoadMap (RISC to RISC)*, SA41-5155
- ▶ *Software Installation*, SC41-5120
- ▶ *Backup and Recovery*, SC41-5304
- ▶ *iSeries Performance Capabilities Reference*, SC41-0607

<http://www-1.ibm.com/servers/eserver/series/perfmgmt/resource.htm>

<http://publib.boulder.ibm.com/infocenter/series/v5r3/ic2924/books/sc410607.pdf>

Online resources

The following Web sites and URLs are also relevant as further information sources:

- ▶ IBM Redbooks home page
<http://www.redbooks.ibm.com>
- ▶ iSeries Online Library
<http://publib.boulder.ibm.com/pubs/html/as400/online/lib.htm>
- ▶ iSeries Information Center
<http://www.ibm.com/eserver/series/infocenter>
- ▶ The ATM Forum
<http://www.atmforum.com>
- ▶ IBM eServer iSeries server
<http://www-1.ibm.com/servers/eserver/series/>
- ▶ iSeries Planning
<http://www.ibm.com/servers/eserver/series/support/planning>
- ▶ Capacity Upgrade on Demand
<http://www-1.ibm.com/servers/eserver/series/hardware/ondemand/>
- ▶ Logical partitioning
<http://www.ibm.com/eserver/series/lpar/>
- ▶ Windows Integration (with iSeries)
<http://www.ibm.com/eserver/series/integratedxseries/>
- ▶ Country- or region-specific keyboard or mouse and display support
<http://www-1.ibm.com/servers/eserver/series/>
- ▶ iSeries software
<http://www.ibm.com/eserver/series/software>

- ▶ Offering Information (OITool)
<http://w3-3.ibm.com/sales/ssi/OIN.wss>
- ▶ Software Subscription for iSeries
<http://www-1.ibm.com/servers/eserver/series/sftsol/subscript.htm>
- ▶ Software Inventory Assistant
<http://www-1.ibm.com/servers/eserver/series/sftsol/siu.htm>
- ▶ Electronic Support Access
<http://www.iseries.ibm.com/tstudio/planning/esa/esa.htm>
- ▶ IBM eServer iSeries Support
<http://www.ibm.com/series400/support>
- ▶ IBM eServer iSeries Resource Library
<http://www.ibm.com/eserver/series/library>
- ▶ iSeries and AS/400 publications: "What's new" by release
<http://publib.boulder.ibm.com/pubs/html/as400/online/chgfrm.htm>
- ▶ PartnerWorld for Developers - IBM eServer iSeries
<http://www.iseries.ibm.com/developer/index.html>

How to get IBM Redbooks

You can search for, view, or download Redbooks, Redpapers, Hints and Tips, draft publications and Additional materials, as well as order hardcopy Redbooks or CD-ROMs, at this Web site:

ibm.com/redbooks

Help from IBM

IBM Support and downloads

ibm.com/support

IBM Global Services

ibm.com/services

Archived



Redbooks

IBM System i5, eServer i5, and iSeries System Builder: IBM i5/OS Version 5 Release 4

(0.5" spine)
0.475" x 0.873"
250 <-> 459 pages



IBM System i5, eServer i5, and iSeries System Builder

IBM i5/OS Version 5 Release 4 - January 2006



Redbooks

The authoritative source for current IBM System i5, eServer i5, and iSeries models

Facts, rules, and placement for the System i5, eServer i5 and iSeries features

Product numbers, prerequisites, storage specifications, and software facts

Welcome to the thirteenth formal edition of the world-renown System Builder. This *IBM System i5, IBM eServer i5, and iSeries System Builder*, SG24-2155, offers you a comprehensive guide to the IBM System i5, IBM eServer i5, and iSeries processor hardware, related hardware, and System i software marketed by IBM representatives since the introduction of the AS/400e servers in 1996. This technical IBM Redbook describes the newest members of the System i product line, the IBM System i5 Models 520, 550, 570 and 595, as well as the IBM eServer i5 Models 520, 550, 570, and 595, and the iSeries Models 800, 810, 825, 870, and Model 890. This redbook has been updated to include changes to the software offerings with the latest release of i5/OS software, IBM i5/OS Version 5 Release 4.

This book is written for use by IBM System Specialists, Marketing Representatives, Business Partners, and clients. Use this System Builder for detailed System i information and configuration rules. Refer to the companion guide *IBM System i5 Handbook*, SG24-7486, as a reference for the latest marketing messages on today's models and software, and *IBM eServer iSeries Migration: A Guide to Upgrades and Migrations to POWER Technology*, SG24-7200, for migration considerations. Placement rules are further described in *PCI and PCI-X Placement Rules for IBM System i5, eServer i5, and iSeries servers with i5/OS V5R4 and V5R3*, REDP-4011.

**INTERNATIONAL
TECHNICAL
SUPPORT
ORGANIZATION**

**BUILDING TECHNICAL
INFORMATION BASED ON
PRACTICAL EXPERIENCE**

IBM Redbooks are developed by the IBM International Technical Support Organization. Experts from IBM, Customers and Partners from around the world create timely technical information based on realistic scenarios. Specific recommendations are provided to help you implement IT solutions more effectively in your environment.

**For more information:
ibm.com/redbooks**

SG24-2155-12

ISBN 073849576X